



DECLARACIÓN RESPONSABLE

D. D^a _____
con DNI número _____ como pai/nai/ titor legal do
alumno/a _____ matriculado no
curso _____ do centro educativo CEE SANTA MARÍA

DECLARO RESPONSABLEMENTE QUE COÑEZO O PROTOCOLO DE ADAPTACIÓN
AO CONTEXTO DA COVID-19 NOS CENTROS de ensino non universitario DE GALICIA
PARA O CURSO 2021-2022

e que, polo tanto coñece a necesidade de obriga de realizar diariamente a enquisa de autoevaluación da Covid-19 ao alumno/a e a obriga de NON enviálo/a ao centro e contactar cos servizos sanitarios e seguir as súas indicacións en caso de presentar cando menos un dos síntomas previstos. De igual xeito coñece a obriga de seguir as indicacións da autoridade sanitaria no caso de que o/a alumno/a conviva cunha persoa con diagnóstico positivo de Covid-19.

O alumno/a non poderá acudir ao centro ata que así llelo indiquen os servizos sanitarios. A persoa afectada ou a súa familia comunicarán estas circunstancias ao Equipo Covid do centro.

En _____ a _____ de _____ de 2021

ASDO _____

ANEXO I ENQUISA DE AUTOAVALIACIÓN CLÍNICA DO Covid-19

Esta enquisa pretende ser útil para que a comunidade educativa poida identificar síntomas clínicos de sospeita de ter infección por coronavirus. De presentar calquera destes síntomas solicite consulta [no seu/súa médico/a ou pediatra.](#)

Presentou nos últimos días?		SI	NON
Síntomas respiratorios	Febre maior de 37,5°C		
	Tose seca		
	Dificultade respiratoria		
Outros síntomas	Fatiga severa (cansazo)		
	Dor muscular		
	Falta de olfacto		
	Falta de gusto		
	Diarrea		

Ten actualmente algún dos síntomas? Sinalar cales e cando comezaron.

		SI	NON
CONVIVIU nos últimos 10 días?	cunha persoa Covid-19 + confirmado?		

RECOMENDACIONES DE PROTECCIÓN FRENTE AO CORONAVIRUS

O LAVADO FRECUENTE DAS MANS proporciona a mellor PROTECCIÓN fronte a COVID-19



LAVADO CORRECTO DE MANOS



Mójate las manos con agua y aplica suficiente jabón



Frótate las palmas de las manos entre sí



Frótate la palma de una mano contra el dorso de la otra entrelazando dedos



40-60"



Frótate las palmas de las manos entre sí con los dedos entrelazados



Frótate el dorso de los dedos de una mano con la palma de la otra



Con un movimiento de rotación, frótate el pulgar atrapándolo con la palma de la otra mano



Frótate los dedos de una mano con la palma de la otra con movimientos de rotación



Enjuágate las manos con agua



Sécate las manos con una toalla de un solo uso

E MOI IMPORTANTE gardar a distancia entre persoas



NON ESQUEZA:

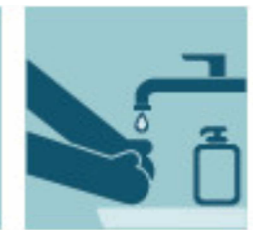

Cúbrase a boca co brazo cando tosa o estornude, ou cun pano desbotable, despois tíreo ao lixo e limpe as mans

Limpe frecuentemente as superficies de contacto (manillas pasamáns...) con desinfectante ou lixivia rebaixada

Lavamos as mans!



Emprega auga e xabón



frota unha palma coa outra



entre os dedos



non esquezas os pulgares!



Aclara con suficiente auga



Seca as máns cun pano desbotable



Lembra lavar as mans durante *40 segundos*.

Podes contar ata 40, cantar o cumpreanos feliz dúas veces...

Tiras de instrucións: **cómo me Lavo as mans**



Pon auga e xabón



Frota palma con palma



Entre os dedos



Non esquezas os pulgares



Aclara ben o xabón



Seca ben as mans



Pon auga e xabón



Frota palma con palma



Entre os dedos



Non esquezas os pulgares



Aclara ben o xabón



Seca ben as mans



Pon auga e xabón



Frota palma con palma



Entre os dedos



Non esquezas os pulgares



Aclara ben o xabón



Seca ben as mans

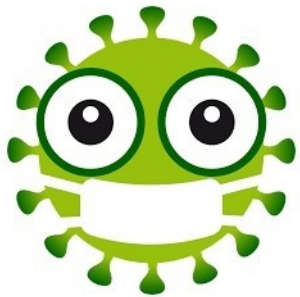

cartel recordatorio das normas de
seguridade

Lembra...



Non esbirres nin
tusas na túa man...



... faino no
cóbado.



Non toques coas
mans os ollos, nariz
ou boca.



Emprega sempre
a mascarilla

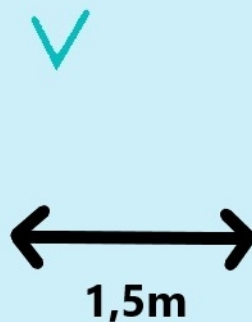

Mantén sempre a distancia de seguridade

Á escola con sentidiño

PROTOCOLO COVID-19

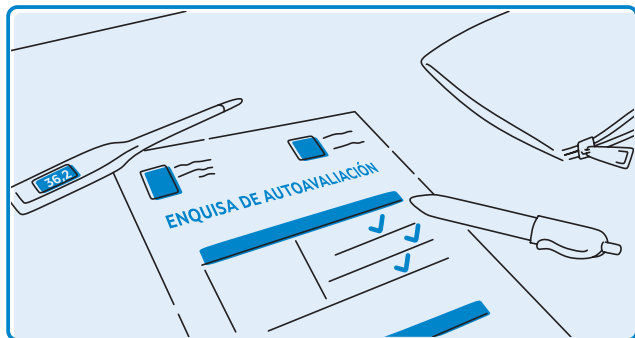

Comprobar se teño algún sintoma da covid-19. De habelo, quedar na casa e chamar ao centro de saúde.

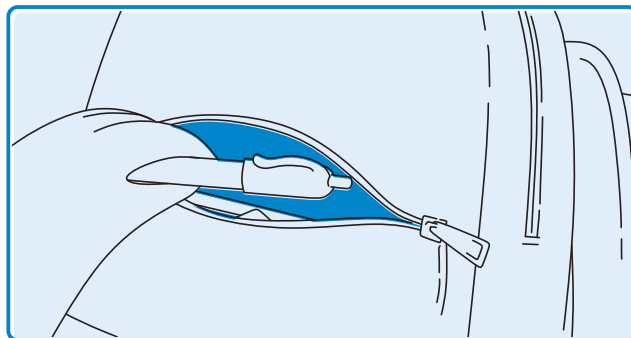

Revisar se vai na mochila todo o material necesario, xa que non se pode compartir.



Levar unha máscara posta e outra de reposto, así como un estoxo para gardala.

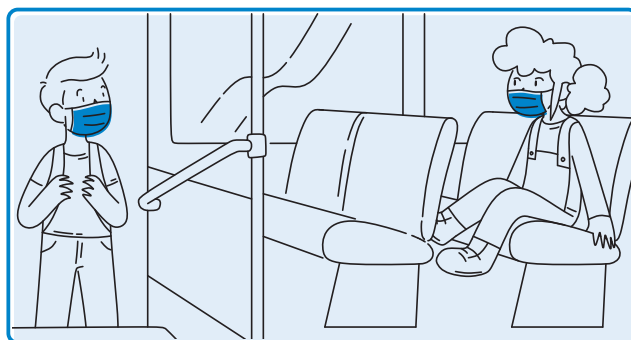

Ir no autobús coa máscara posta e sempre no mesmo asento.

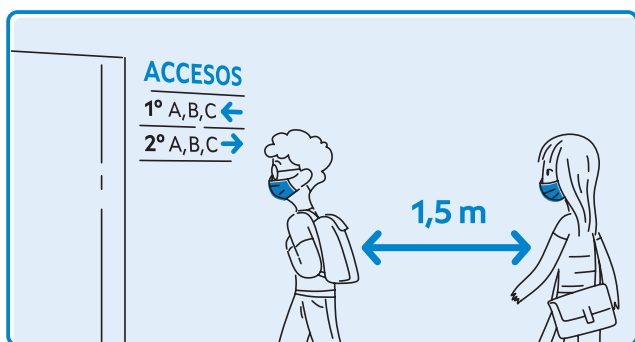

Acceder pola entrada e na quenda que me correspondan, mantendo a distancia.

#SENTIDIÑO

PROTEXÁMONOS A NÓS MESMOS
E AOS QUE NOS RODEAN

Uso da máscara

PROTOCOLO COVID-19

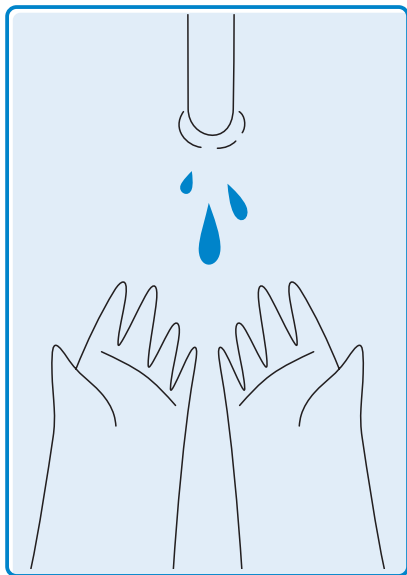

Lava ben as mans con auga e xabón ou hixienízaas con xel hidro-alcohólico antes de coller a máscara.

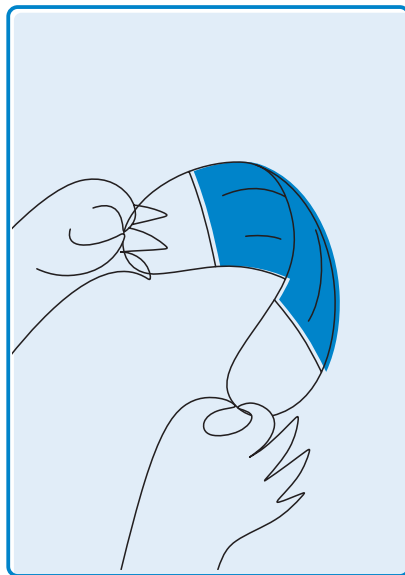

Colle a máscara polas bandas elásticas evitando tocar o tecido.

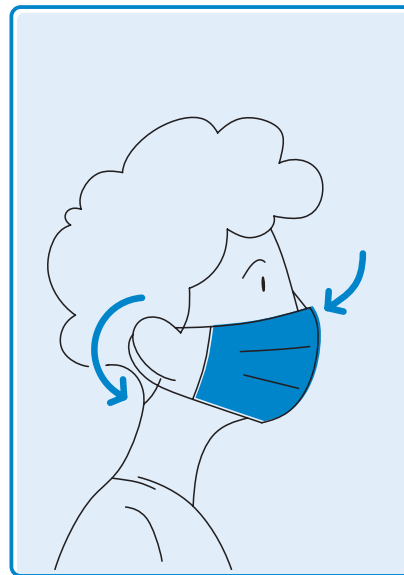

Pon a máscara sobre a cara cubrindo boca e nariz, axusta as tiras detrás das orellas e a pinza nasal.



Non quites a máscara para falar, tusir ou estornudar. Tampouco a apartes da boca e nariz.



Para retirar a máscara, volve collela polas bandas elásticas evitando tocar o tecido.

#SENTIDIÑO
PROTEXÁMONOS A NÓS MESMOS
E AOS QUE NOS RODEAN

GUIA PARA USAR A MÁSCARA

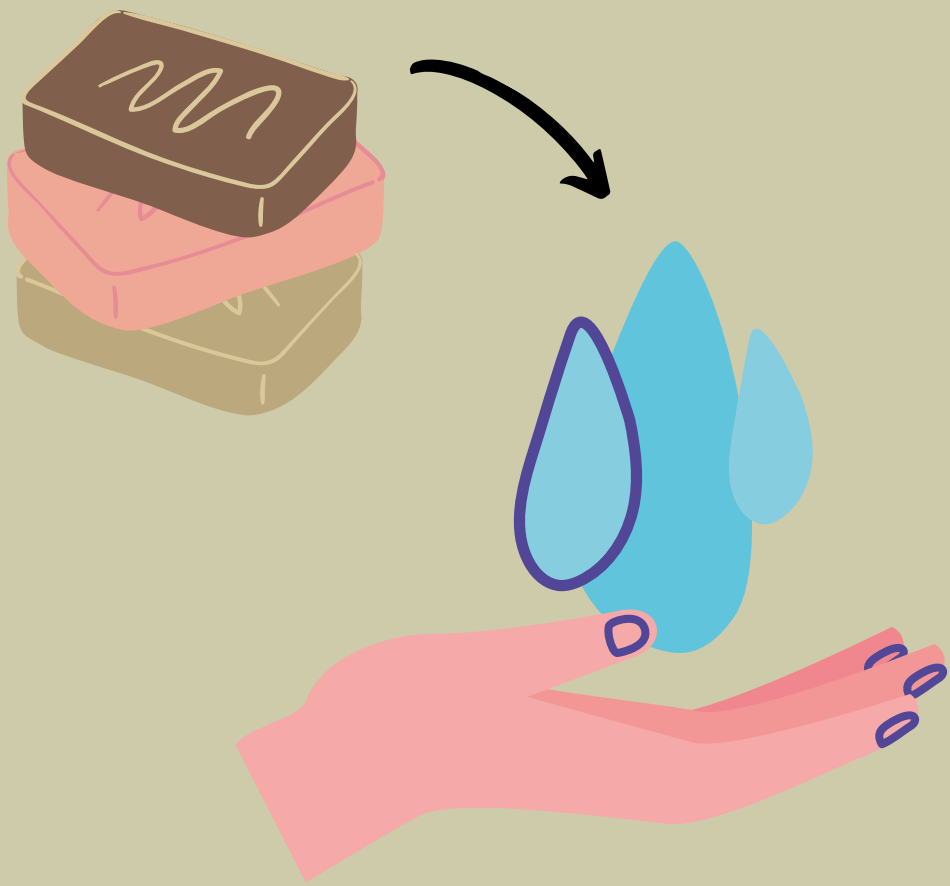

Antes de poñer a máscara lava as mans con auga e xabón ou desinféctaa con xel..



Cobre a boca e o narís coa máscar e axústaa ben, que non queden ocos.

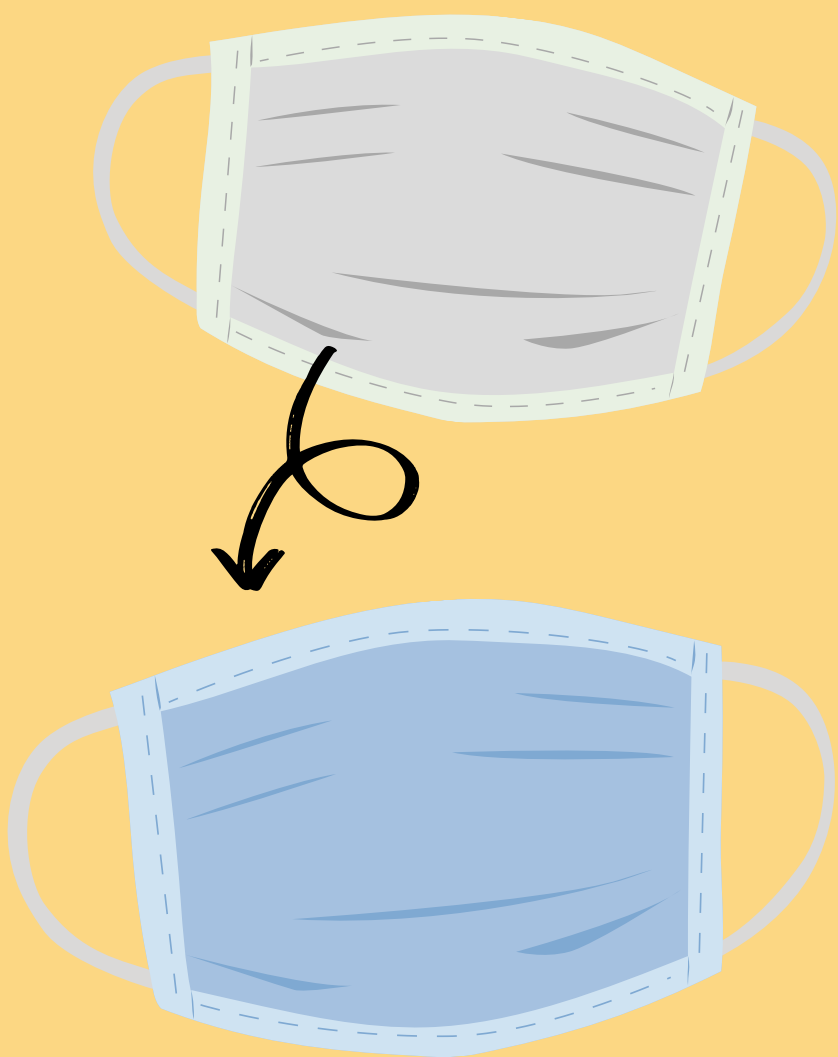

Reemplaza a máscara se está húmida ou sucia, non reutilices as máscaras dun só uso.

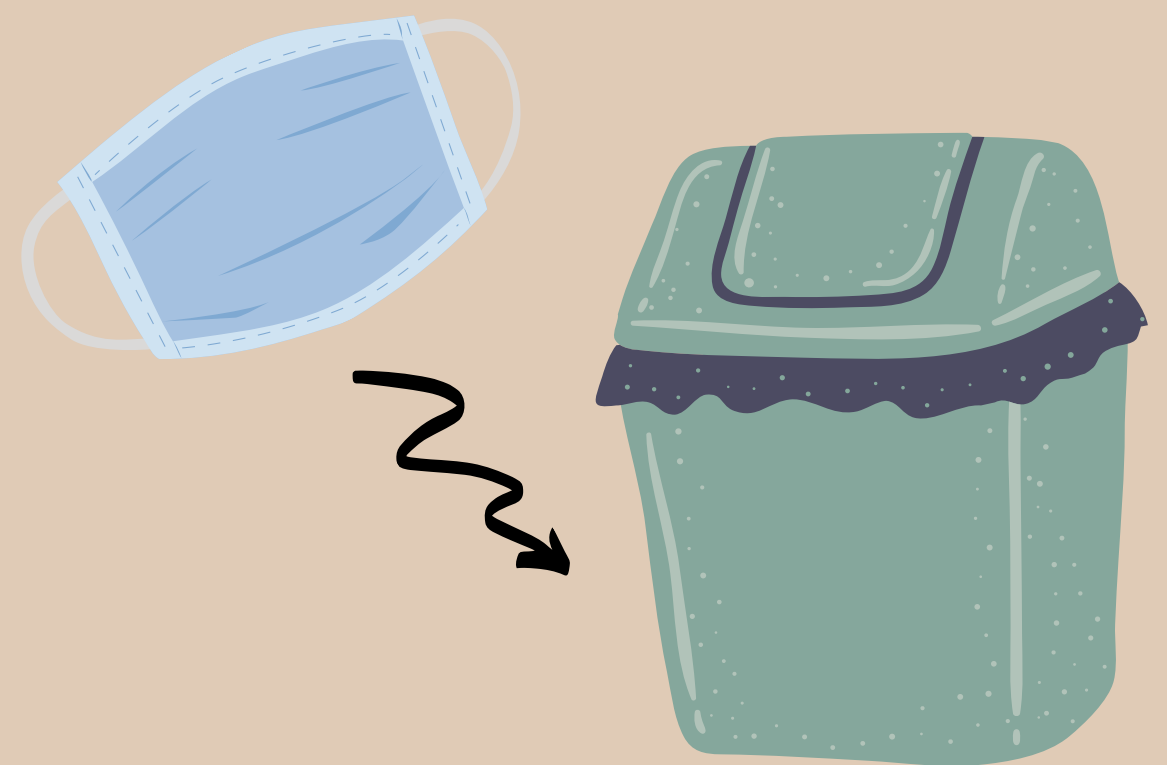

Para tirar a máscara: cóllea polas gomas, non toques a parte frontal da máscara e bótaa de seguido nunha papeleira con tapa.. Lava as mans con auga e xabón ou desinféctaa con xel.

se te coidas ti, coidámonos todos

Mans seguras

PROTOCOLO COVID-19

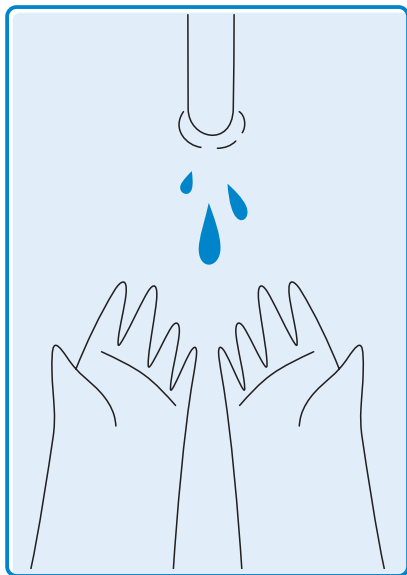

Molla as mans con auga.



Pon na palma xabón suficiente para cubrir as mans.

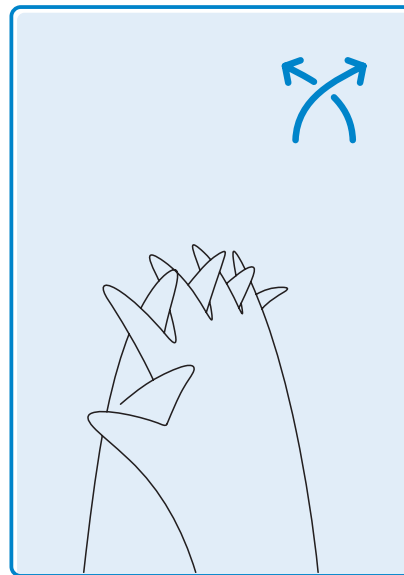

Frega as palmas das mans entre sí entrelazando os dedos.

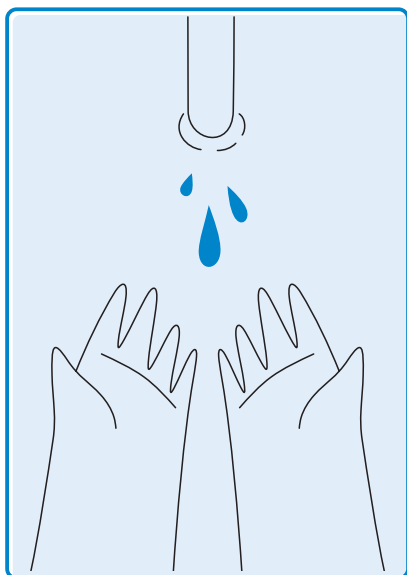

Aclara de novo as mans con auga.

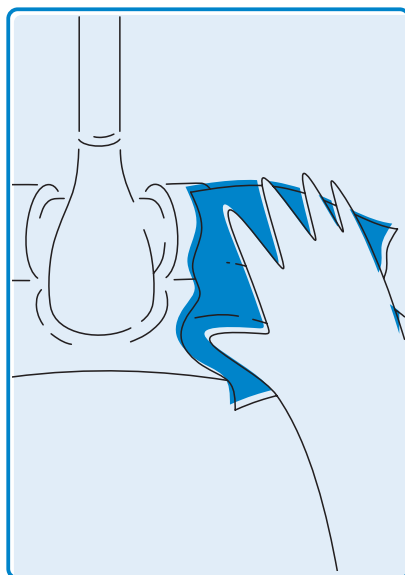

Seca as mans e pecha a billa cun pano desbotable.

#SENTIDIÑO
PROTEXÁMONOS A NÓS MESMOS
E AOS QUE NOS RODEAN

 XUNTA
DE GALICIA

Medidas xerais

PROTOCOLO COVID-19

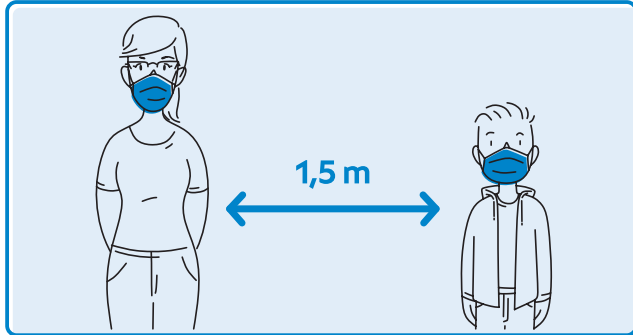

Respectar a distancia de seguridade de 1,5 m entre persoas.

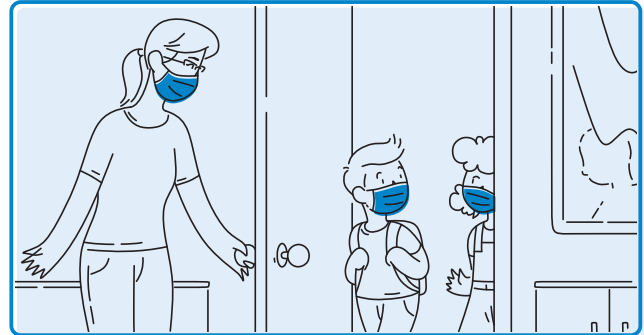

Obriga de usar máscara en todos os espazos do centro.

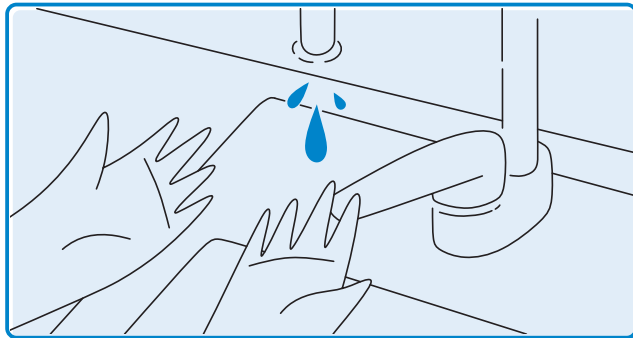

Lavar con frecuencia as mans con auga e xabón, polo menos 5 veces.



Circular en sentido único nos corredores atendendo a sinalización.

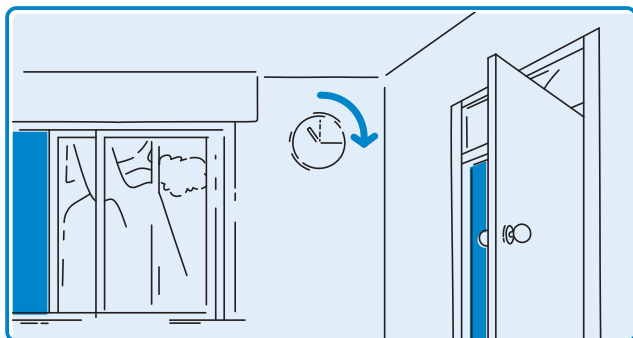

Ventilar con frecuencia as instalacións e polo menos durante 15 minutos.

#SENTIDIÑO
PROTEXÁMONOS A NÓS MESMOS
E AOS QUE NOS RODEAN

Normas na aula

PROTOCOLO COVID-19

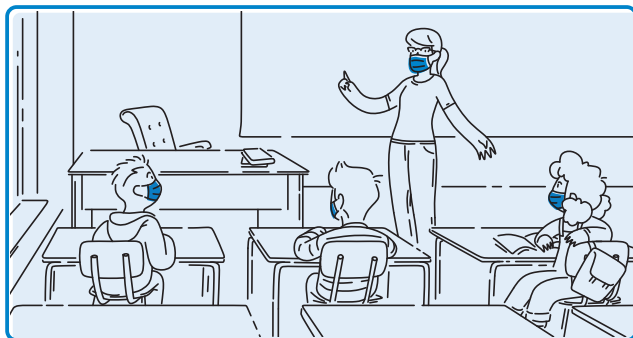

Usar a máscara é obrigatorio.

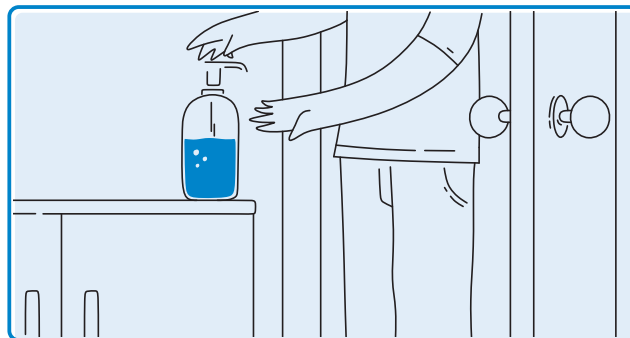

Hixienizar as mans cos dispensadores de xel hidro-alcohólico na entrada da aula.

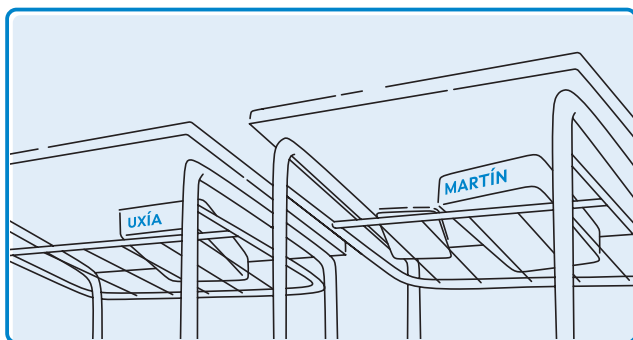

Gardar o material de xeito persoal e diferenciado.

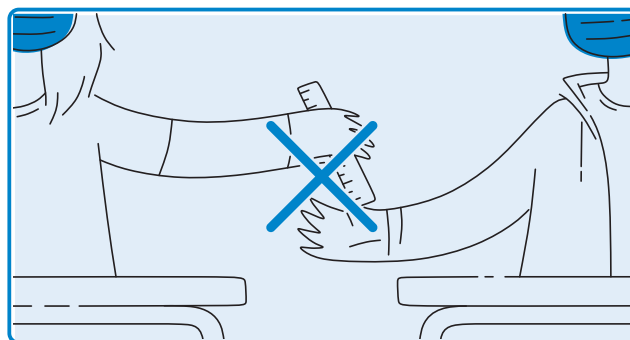

Non compartir material de uso propio.

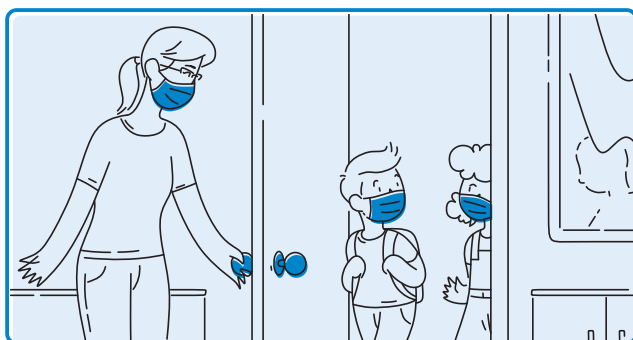

Ventás, portas, interruptores e ferramentas pedagóxicas serán usadas só polo profesorado.

#SENTIDIÑO

PROTEXÁMONOS A NÓS MESMOS
E AOS QUE NOS RODEAN

Espazo de illamento

PROTOCOLO COVID-19



A persoa con síntomas e quen quede ao seu coidado deben poñer unha máscara cirúrxica.

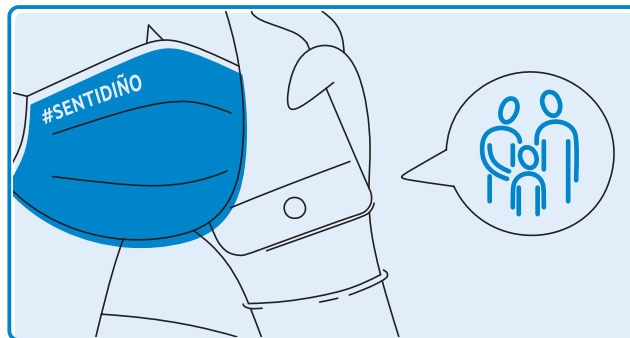

Contactar coa familia, no caso de afectar ao alumnado.

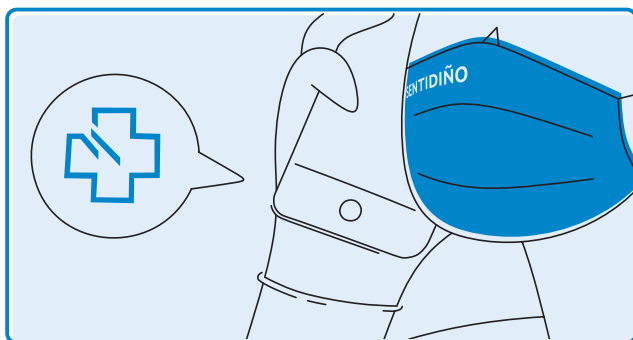

Chamar ao centro de saúde de referencia. De haber síntomas de gravidade, ao 061.

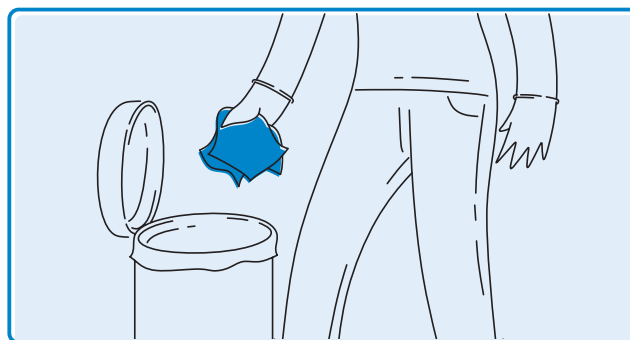

Refugar en papeleiras ou contedores con tapa os panos desbotables utilizados.

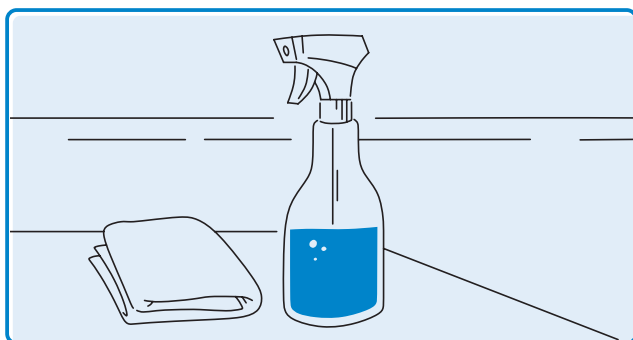

Proceder á limpeza do espazo logo de que a persoa illada abandone o centro educativo.

#SENTIDIÑO
PROTEXÁMONOS A NÓS MESMOS
E AOS QUE NOS RODEAN

 XUNTA
DE GALICIA

¿Cómo se coloca una mascarilla?

1



Lávate las manos durante 40-60 segundos antes de manipularla.

2

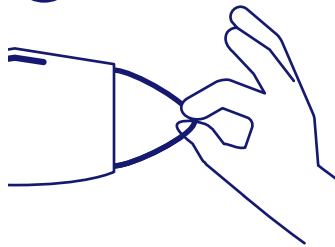

Toca solo las gomas de la mascarilla.

3

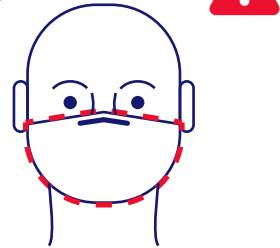

Póntela sobre nariz y boca, asegurándote de que no quedan grandes espacios entre tu cara y la mascarilla.

4

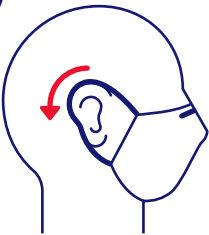

Pasa las bandas elásticas por detrás de tus orejas.

5



Pellizca la pinza nasal para ajustarla bien a la nariz.

6



Evita tocar la parte exterior de la mascarilla. Si lo haces, lávate las manos antes y después.

7



Antes de quitarte la mascarilla, lávate las manos.

8



Retírala tocando sólo las bandas elásticas.

9



Para desecharla, introdúcela en una bolsa de plástico. Deposítala cerrada en la basura y lávate las manos.



SAIAMOS DISTO CON SENTIDIÑO

NON TIREMOS POLA BORDA O TRABALLO FEITO ATA AGORA

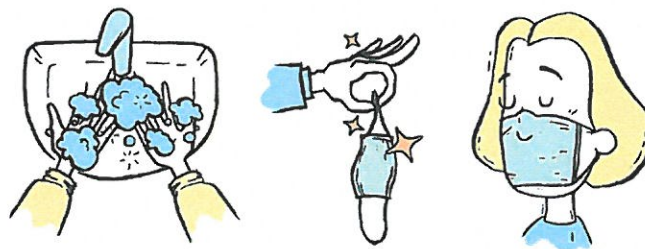

Antes de poñer unha máscara, debes lavar as mans adecuadamente.
Cubre a boca e o nariz, e asegúrate de que non hai ocos entre a máscara e a cara.

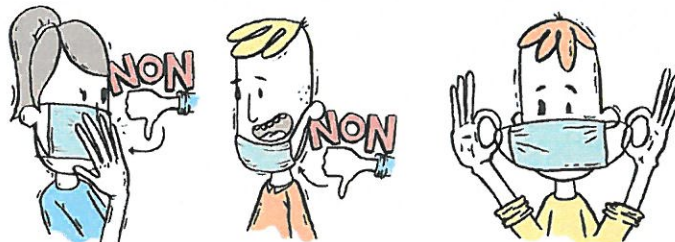

Evita tocala mentres a uses, e non a poñas na fronte ou debaixo da barbilla.
Para retirar a máscara, quítea pola parte traseira sen tocar o frontal e
lava as mans novamente con auga e xabón.

**Non reutilices máscaras dun só uso. As máscaras só son efectivas
cando se usan en combinación cunha hixiene de mans adecuada.**

#SENTIDIÑO
PROTEXÁMONOS A NÓS MESMOS
E AOS QUE NOS RODEAN



XUNTA
DE GALICIA

coronavirus.sergas.gal
900 400 116





XUNTA DE GALICIA
CONSELLERÍA DE CULTURA,
EDUCACIÓN E UNIVERSIDADE



XUNTA DE GALICIA
CONSELLERÍA DE SANIDADE



Mantéña a distancia de seguridade



Xacobeo 21-22

ANEXO II:

1. **No caso do transporte escolar:** establecerase un radio de 2 metros para a identificar a rede de contactos de cada un dos/as alumnos/as

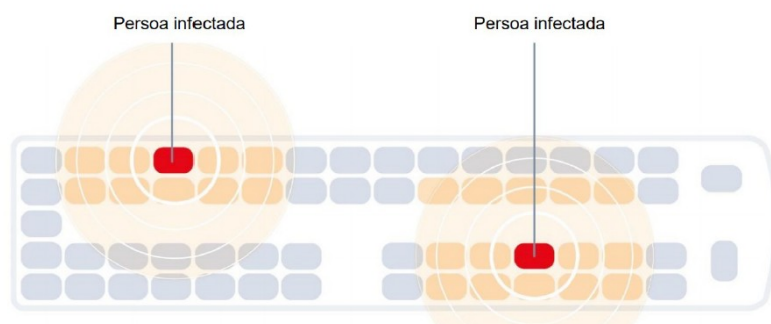

2. **No caso de aulas, laboratorios, comedores e outros espazos:** adoptarase o mesmo criterio do radio de 2 metros arredor da persoa positiva.



“Protocolos de vixilancia e control epidemiolóxico fronte ao virus SARS-CoV-2 (Covid-19) no ámbito educativo non universitario de Galicia”. (<https://coronavirus.sergas.gal/Contidos/Informaci%C3%B3n-Covid-centros-educativos.>)

ANEXO XVI: CARTELERÍA

No Portal da Dirección dispórase doutra cartelería adicional

Coronavirus

Consellos para realizar unha hixiene de mans adecuada

Fuente: Organización Mundial de Saúde



1 Moixe as mans con auga



2 Deposita na palma da man unha cantidade de sabón suficiente para cubrir toda a superficie das mans



3 Fregue as palmas das mans entre si



4 Fregue a palma da man dereita contra o dorso da man esquerda entrelazando os dedos e viceversa



5 Fregue as palmas das mans entre si, cos dedos entrelazados



6 Fregue o dorso dos dedos dunha man coa palma da man oposta, agarrando os dedos



7 Fregue cos movementos de rotación o pulgar esquerda, atrapándoo coa palma da man dereita e viceversa



8 Fregue o punta dos dedos da man dereita contra a palma da man esquerda, facendo un movemento de rotación e viceversa



9 Enxaugue as mans con auga



10 Séquese cun pano desbotable



11 Sirvase dese pano para pechar a billa



12 As súas mans son seguras



XUNTA
DE GALICIA

Máis información en
coronavirus.sergas.gal

