

vocabulario artístico

ABOCINADO: Díse de calquer vano cuia anchura aumenta ou diminúe progresivamente. Son característicos do Románico, principalmente, aínda que tamén o atopamos nas portadas góticas, entre os séculos XI e XV, como podemos apreciar no *Pórtico da Gloria da Catedral de Santiago de Compostela*.

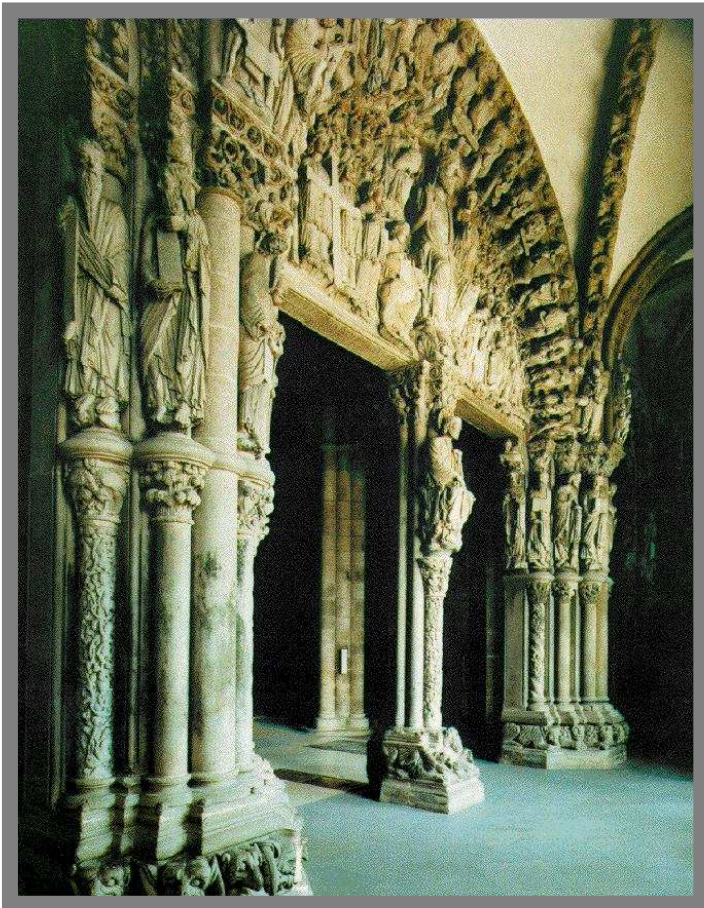



ÁBSIDA: cámara sita na cabeceira dun edificio, xeralmente dunha igrexa, que ten forma semicircular ou poligonal.



Ábsida



ALTORRELEVO: relevo que ten as figuras talladas casi de vulto redondo, pero adheridas ó plano.

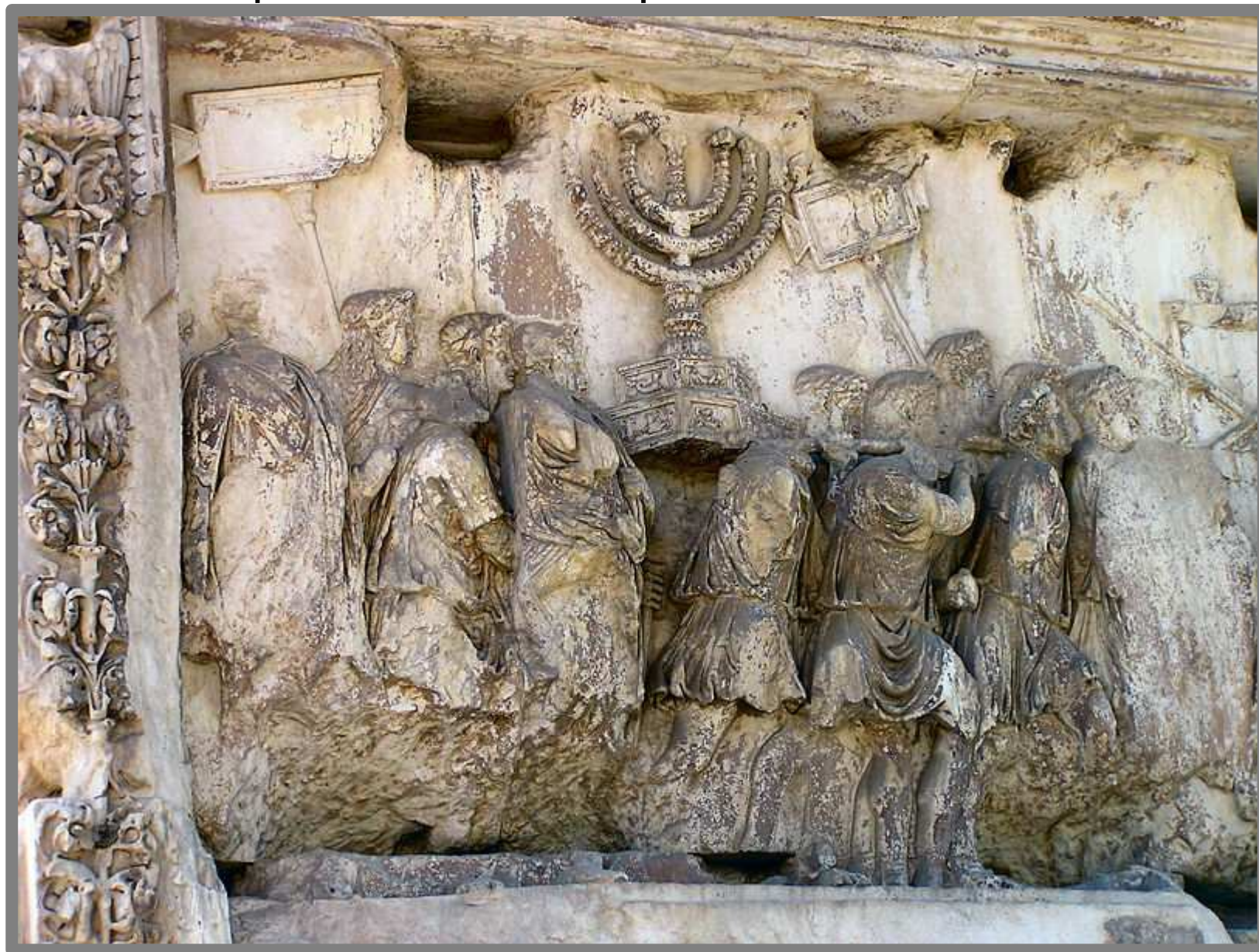



APARELLO DE CANTERÍA: formado por pedras grandes, labradas a escadra, formando masas ortogonais ou paralelepípedos rectos.



Arco: elemento curvo, de función sustentante, que recibe os empuxes superiores e os desvía hacia os laterais. Habitualmente xera un van ou oco que permite franquear o espesor do muro no que o arco se inscribe.





CLAVE DUN ARCO

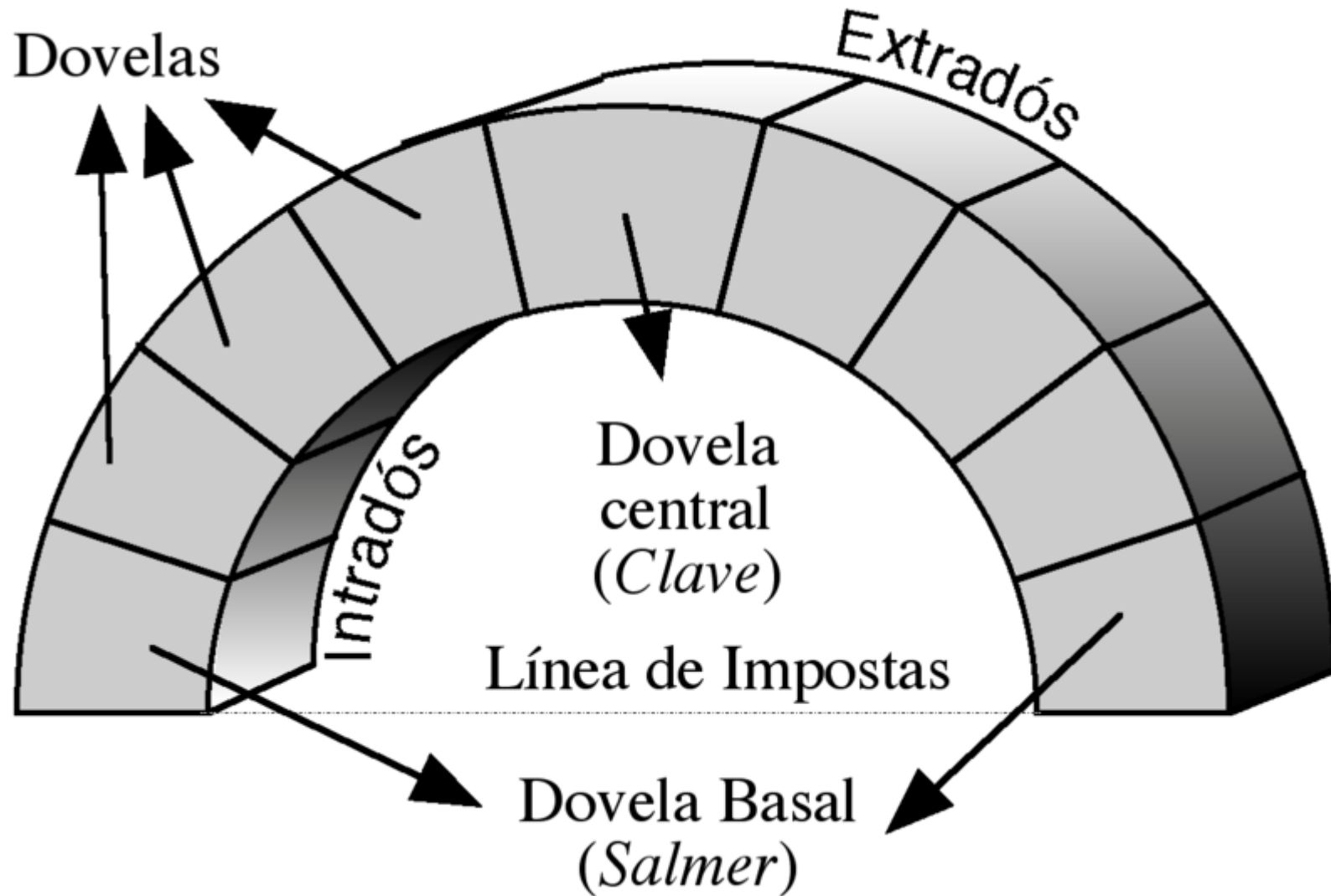



ARCOBOTANTE: estrutura en forma de medio arco, posta no exterior dun edificio que contrarresta os empuxes das bóvedas ó descargalas sobre os contrafortes.

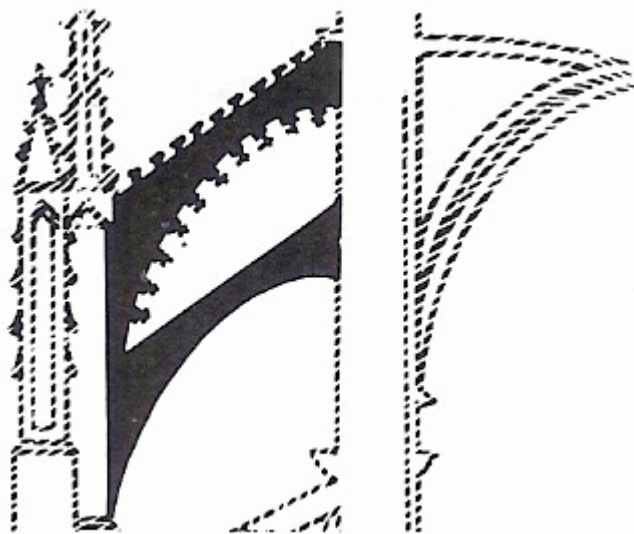



Algúns tipos de arco:

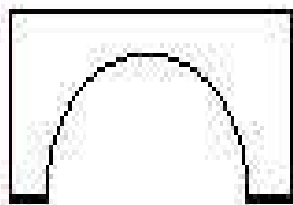

Medio punto

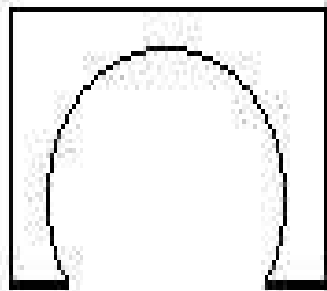

Herradura

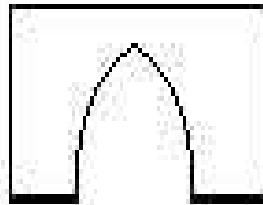

Apuntado

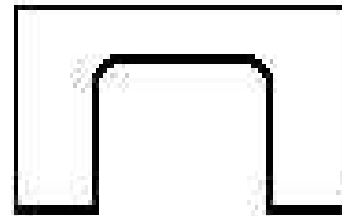

Carpanel

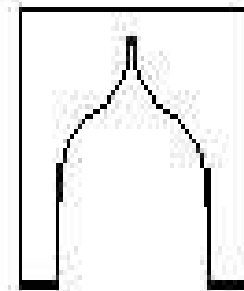

Conopial



Rebajado

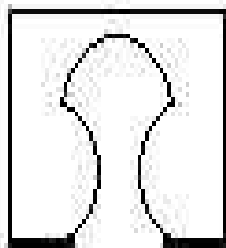

En gola

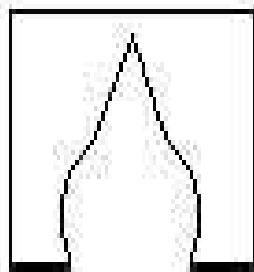

Tudor

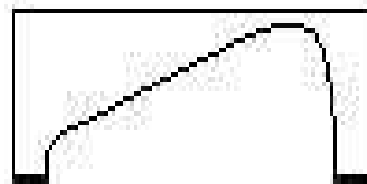

Rampante

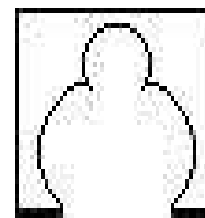

Lobulado

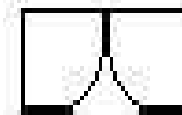

Cortina

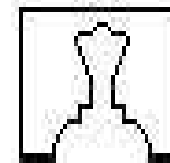

Mixtilíneo



Arco de medio punto

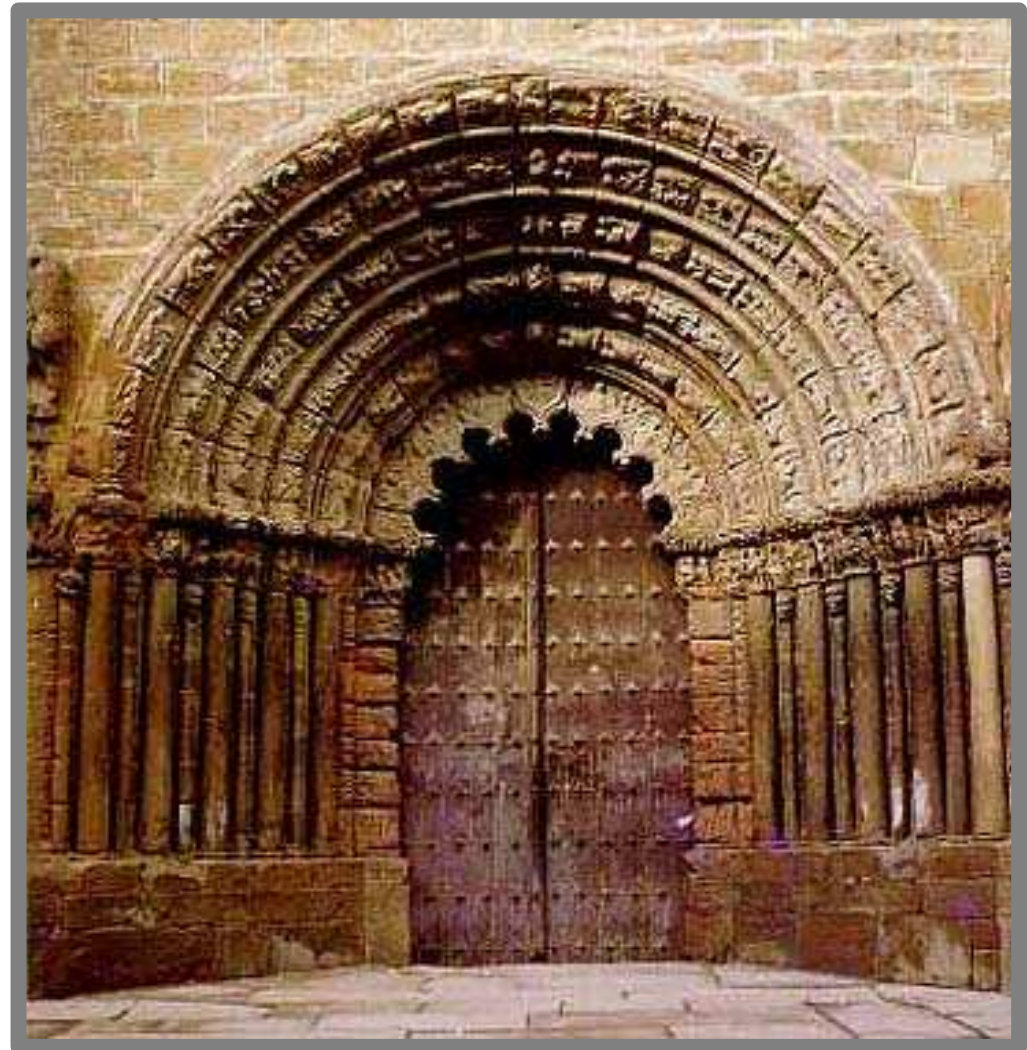
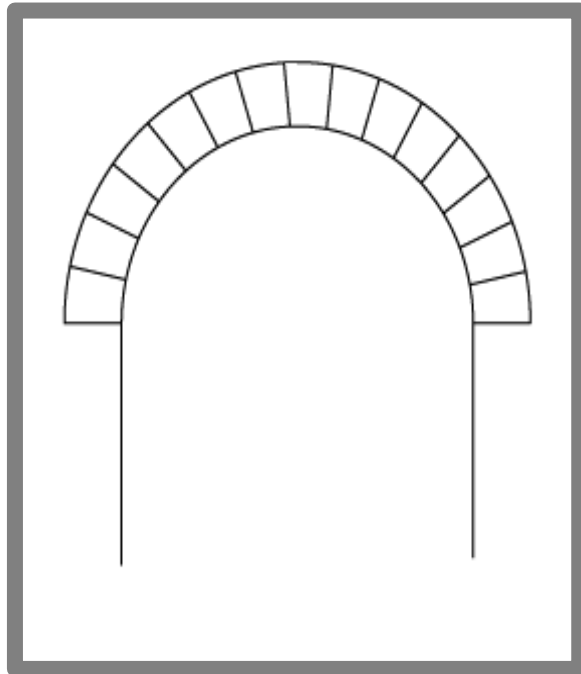



ARCO DE FAIXA ou faxón: é o situado na nave maior, perpendicularmente ó eixe da igrexa, reforza a estrutura das bóvedas xeralmente de cañón ou de arista.

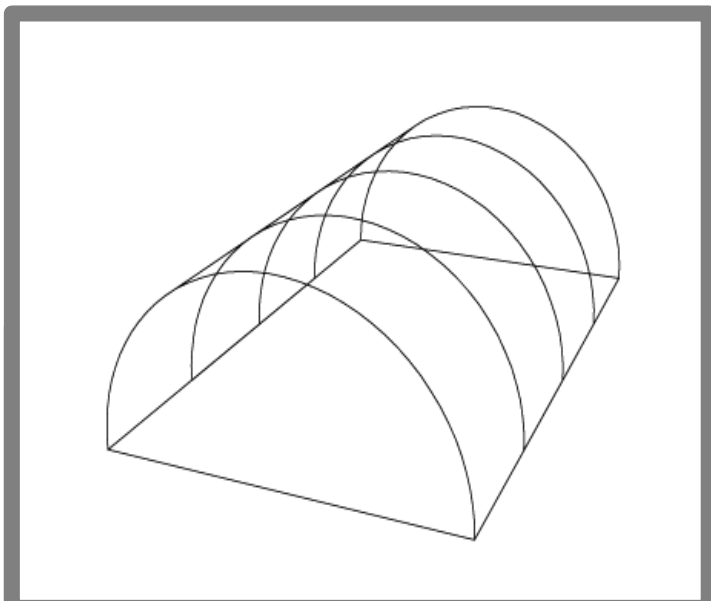



ARCO FORMEIRO: (tamén chamado arco perpiaño) é un arco paralelo ó eixe da nave central, del parten as columnas que dividen o espacio dunha igrexa en naves.

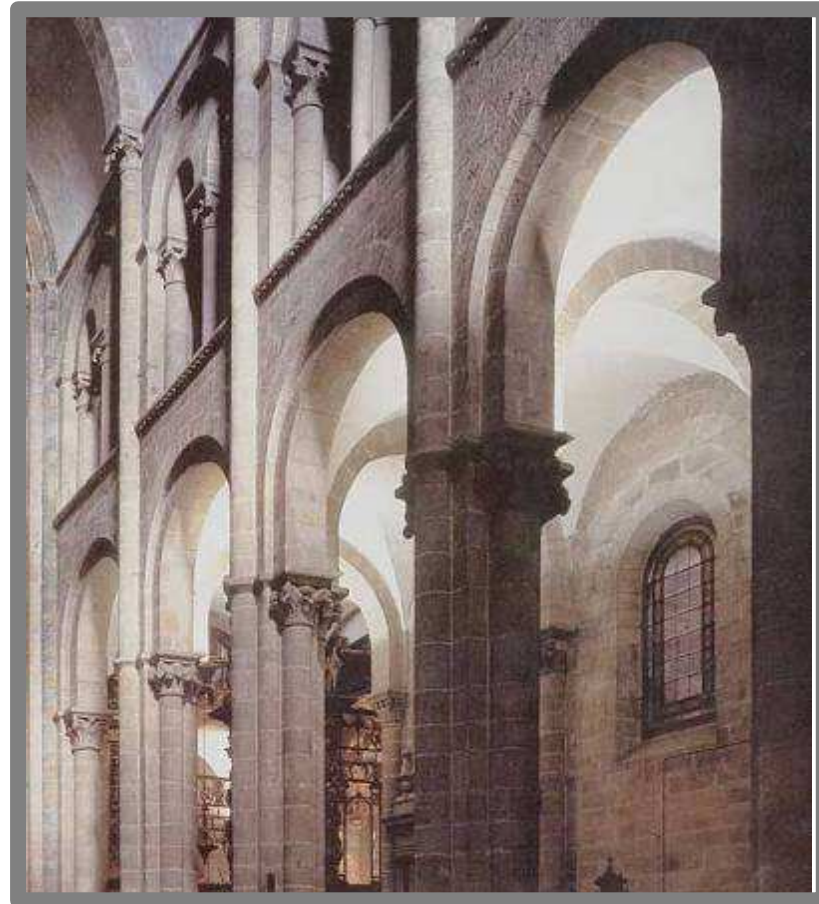



ARQUITRABE: elemento sustentante horizontal, a modo de viga sostida por columnas. Chámase sistema arquitrabado, ó que se sirve de solucións horizontais ou arquitrabes. Oponse ó sistema abovedado.

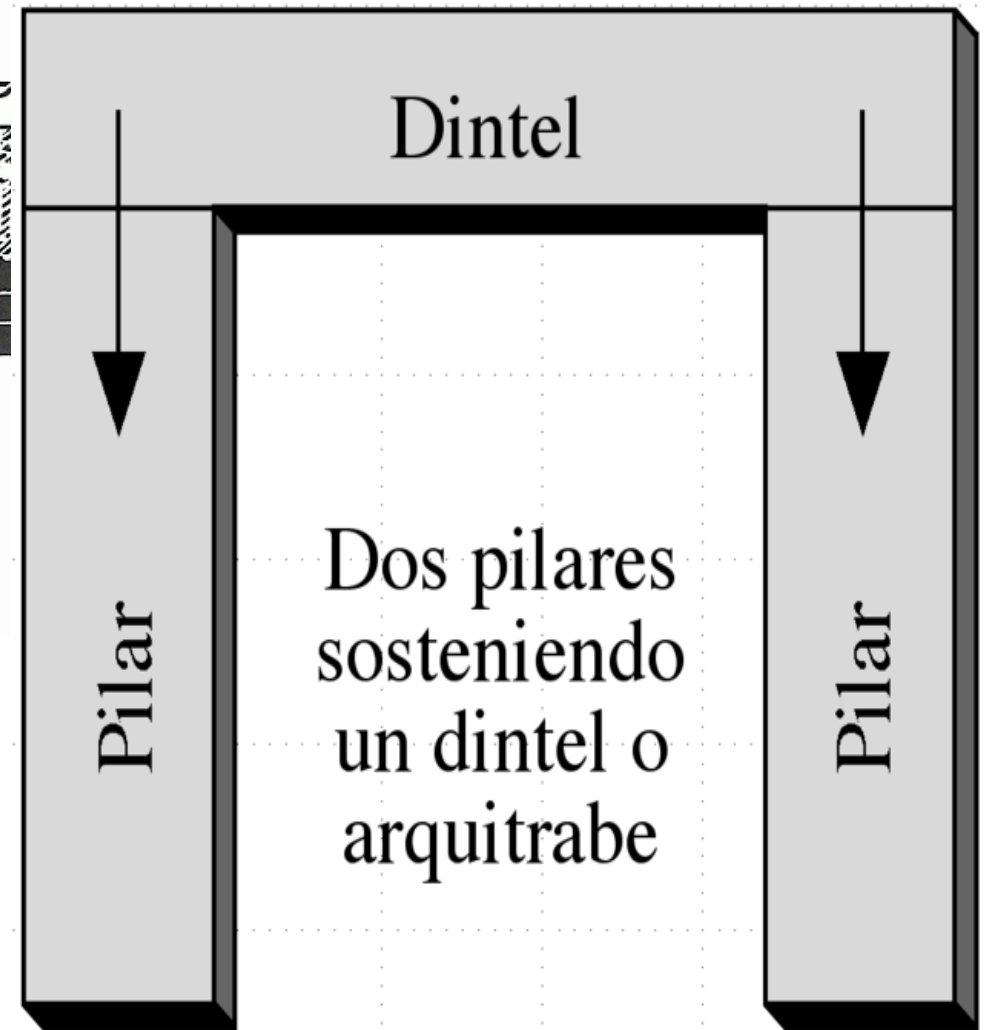
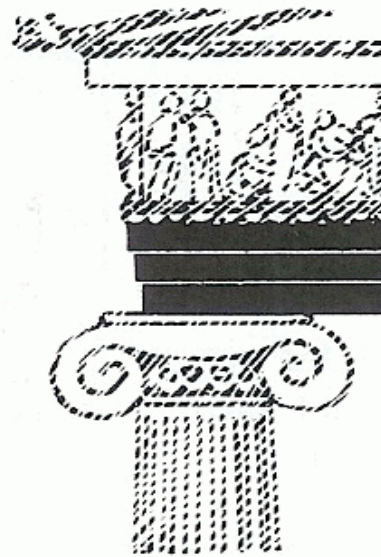
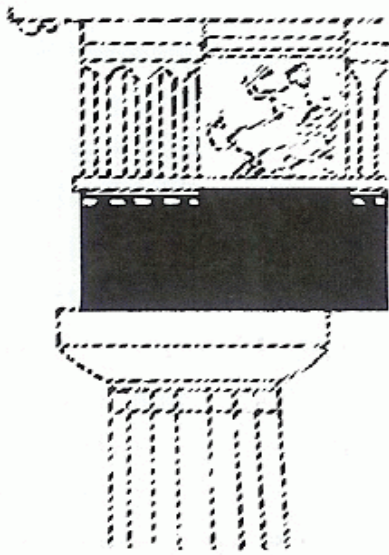



ARQUIVOLTA: cara frontal dun arco. No Románico, conxunto de arcos abocinados dunha portada.

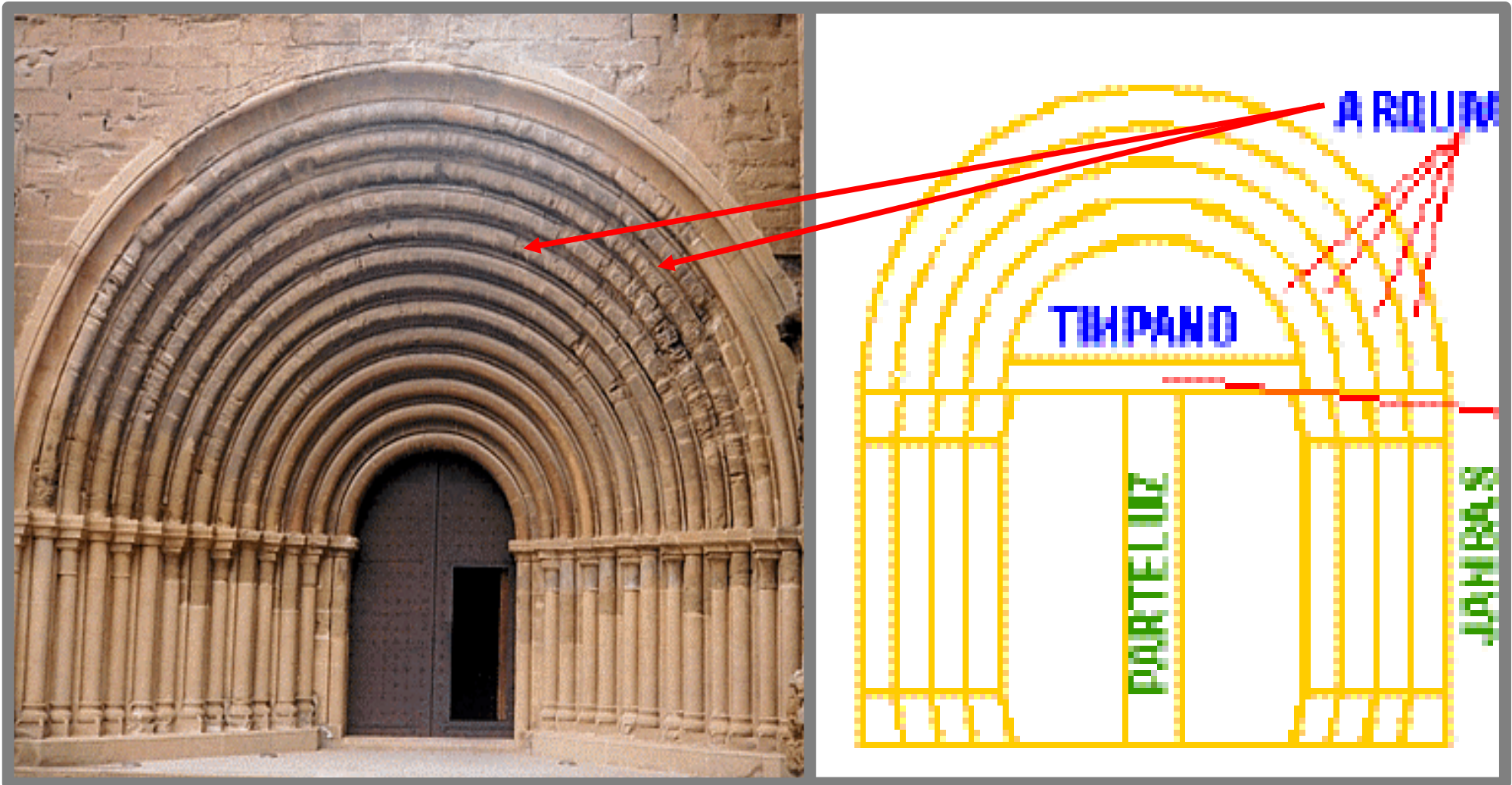

BAIXORRELEVO: relevo cujo resalte é quase plano.

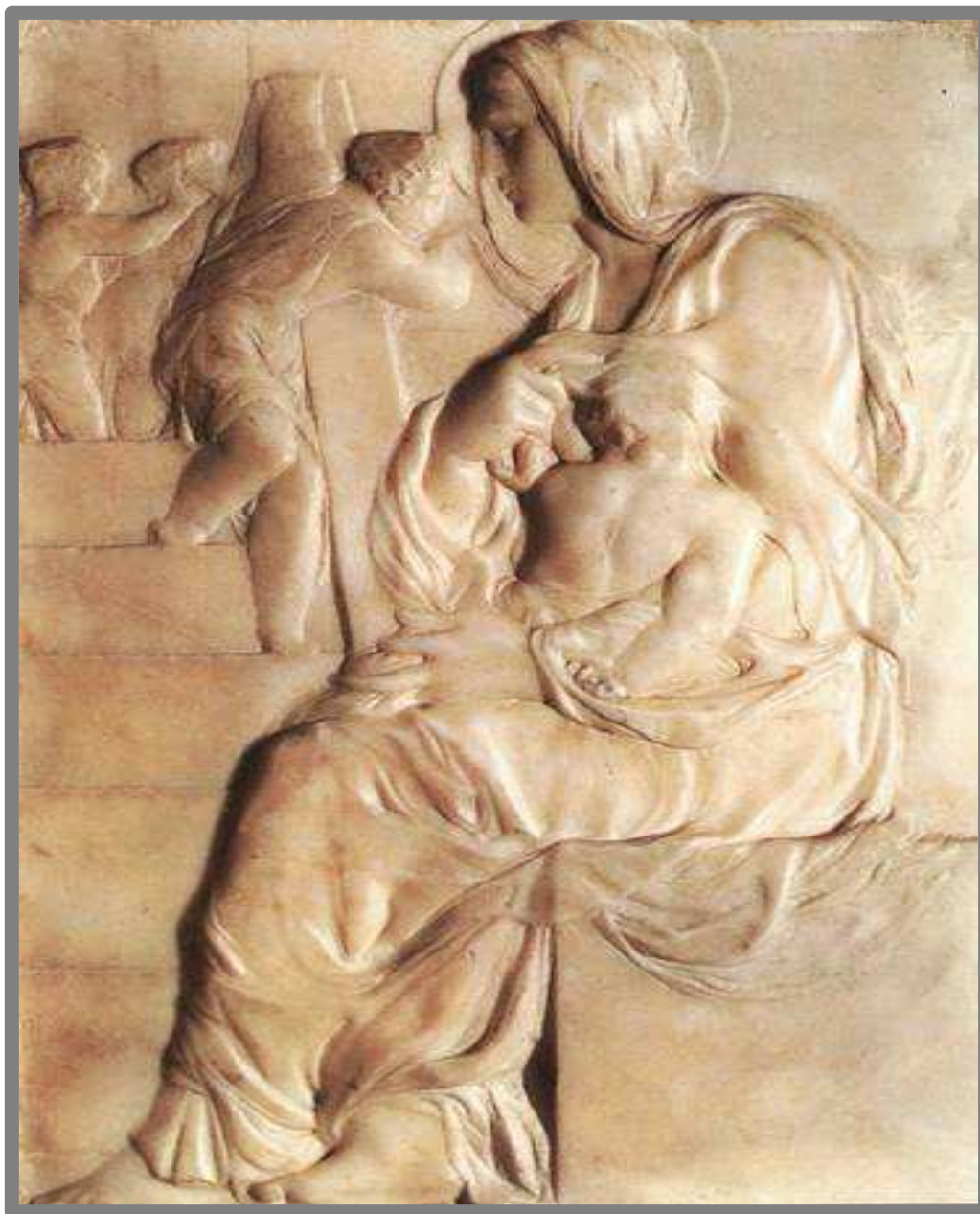



BALDAQUINO: cuberta firme a modo de pavillón aberto sostido por catro ou máis columnas, co que se cubre un altar, un púlpito, unha tumba ou no gótico unha estatua. Tamén sobre o pórtico de igrexas.





A **arquitectura barroca** abandona a serenidade clásica para expresar un mundo en movemento e axitación dos sentidos, distínguese por posuir unha exuberancia decorativa, que cubre o interior e exterior de moitos edificios, sobre todo igrexas.





BASE: peza inferior da columna, situada entre o pavimento e o fuste.

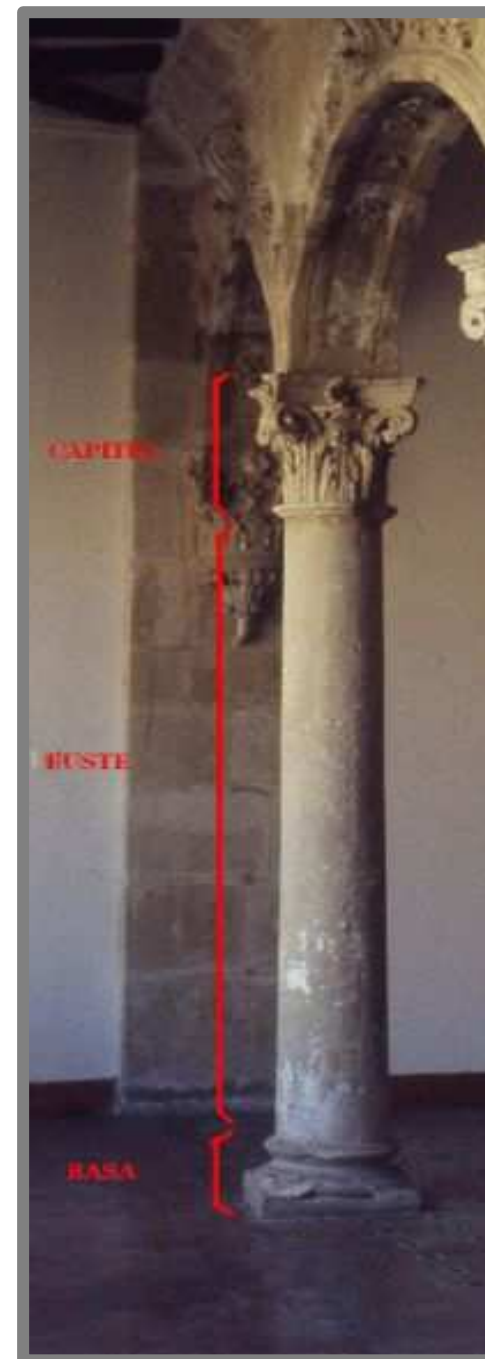
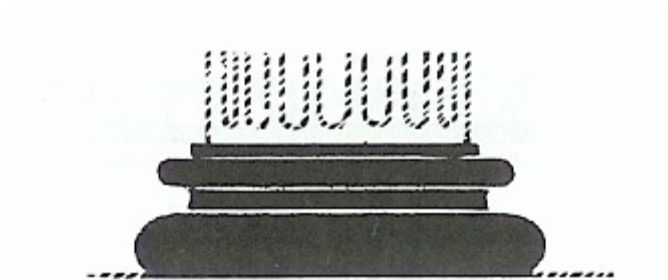
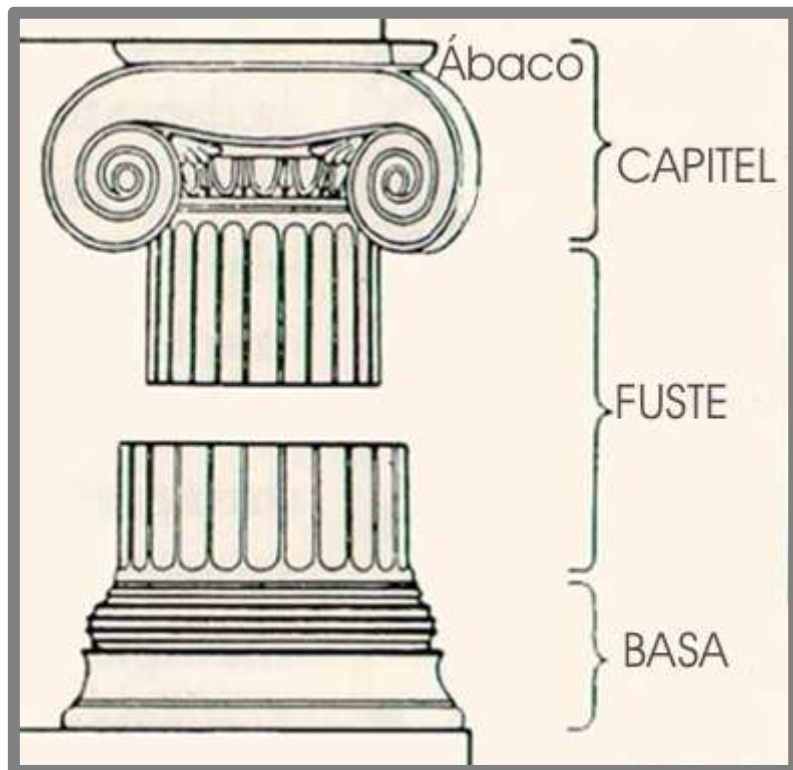



BÓVEDA DE ARESTA





Bóveda de Canón





BÓVEDA DE CRUCERÍA APUNTADA

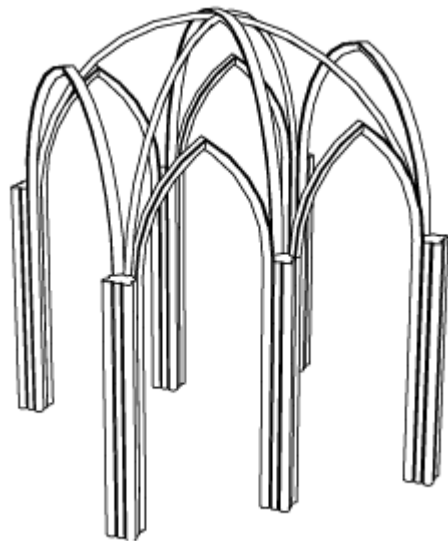
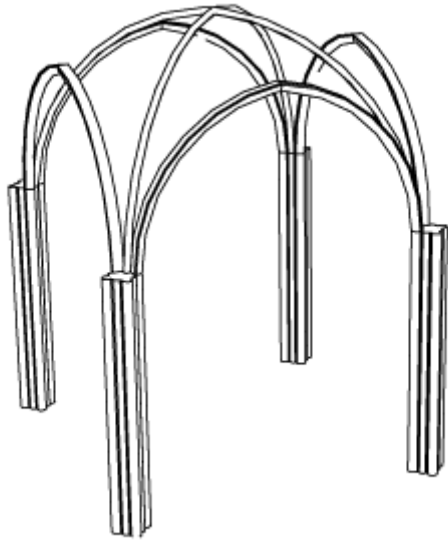

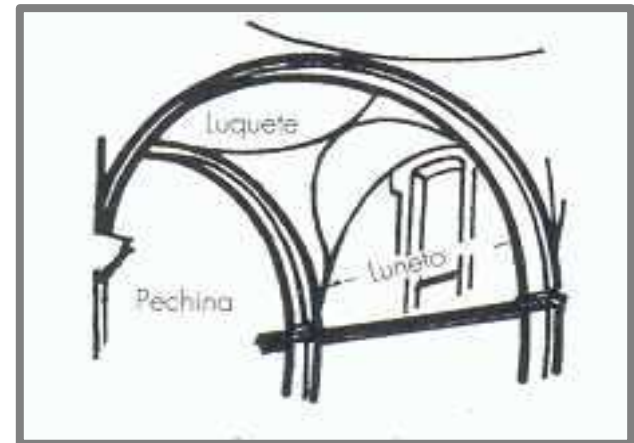
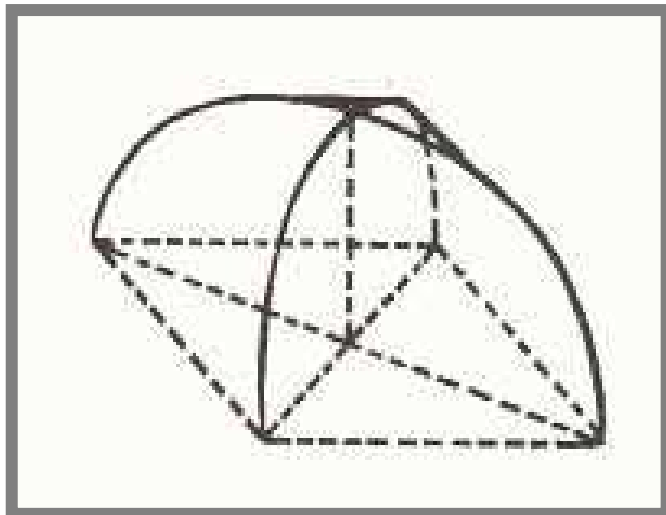
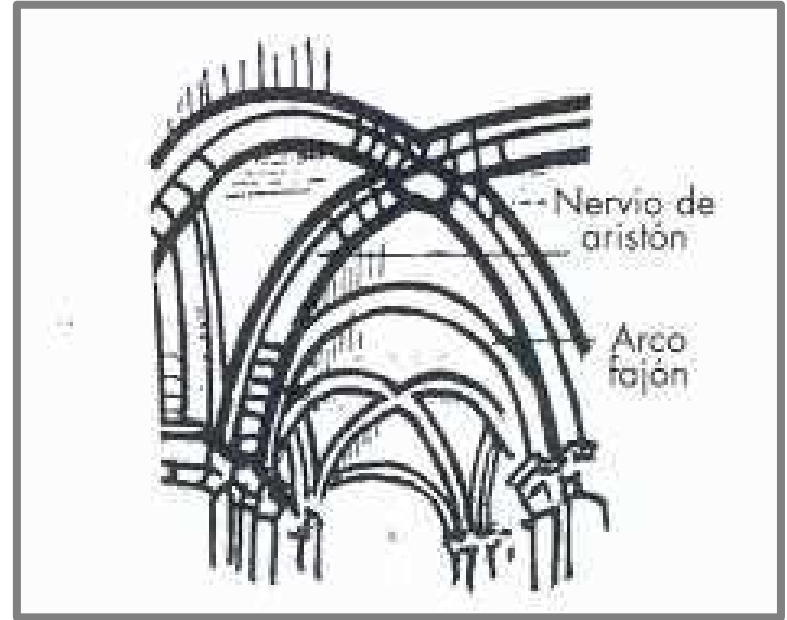
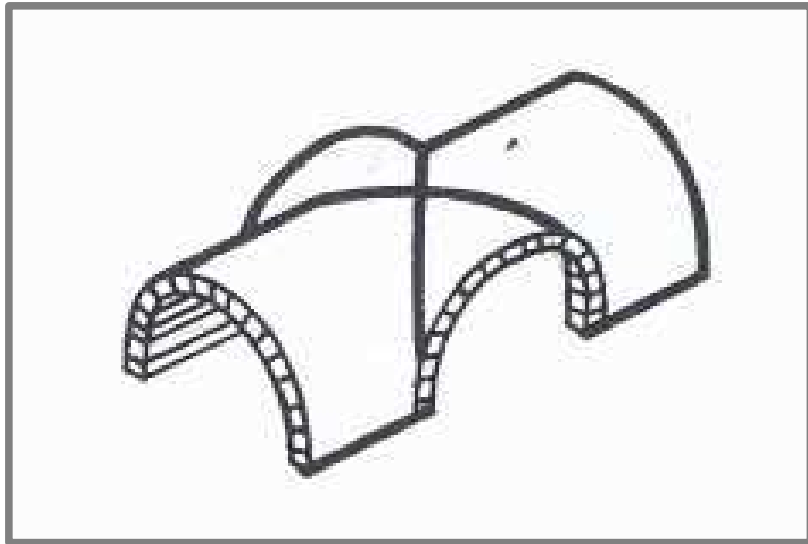



CIBORIO construcción elevada sobre o cruceiro en forma de torre de planta cadrada ou octogonal, coa función de iluminar o interior do edificio. Frecuente nas igrexas románicas.





COLUMNA SALOMÓNICA, en arte a columna torsa ou entorchada, é unha columna de forma helicoidal, que se utilizou fundamentalmente en Europa na arquitectura barroca.





Contraforte elemento sustentante que se adosa ós muros para conter o empuxe das bóvedas. Tamén se denomina estribo.

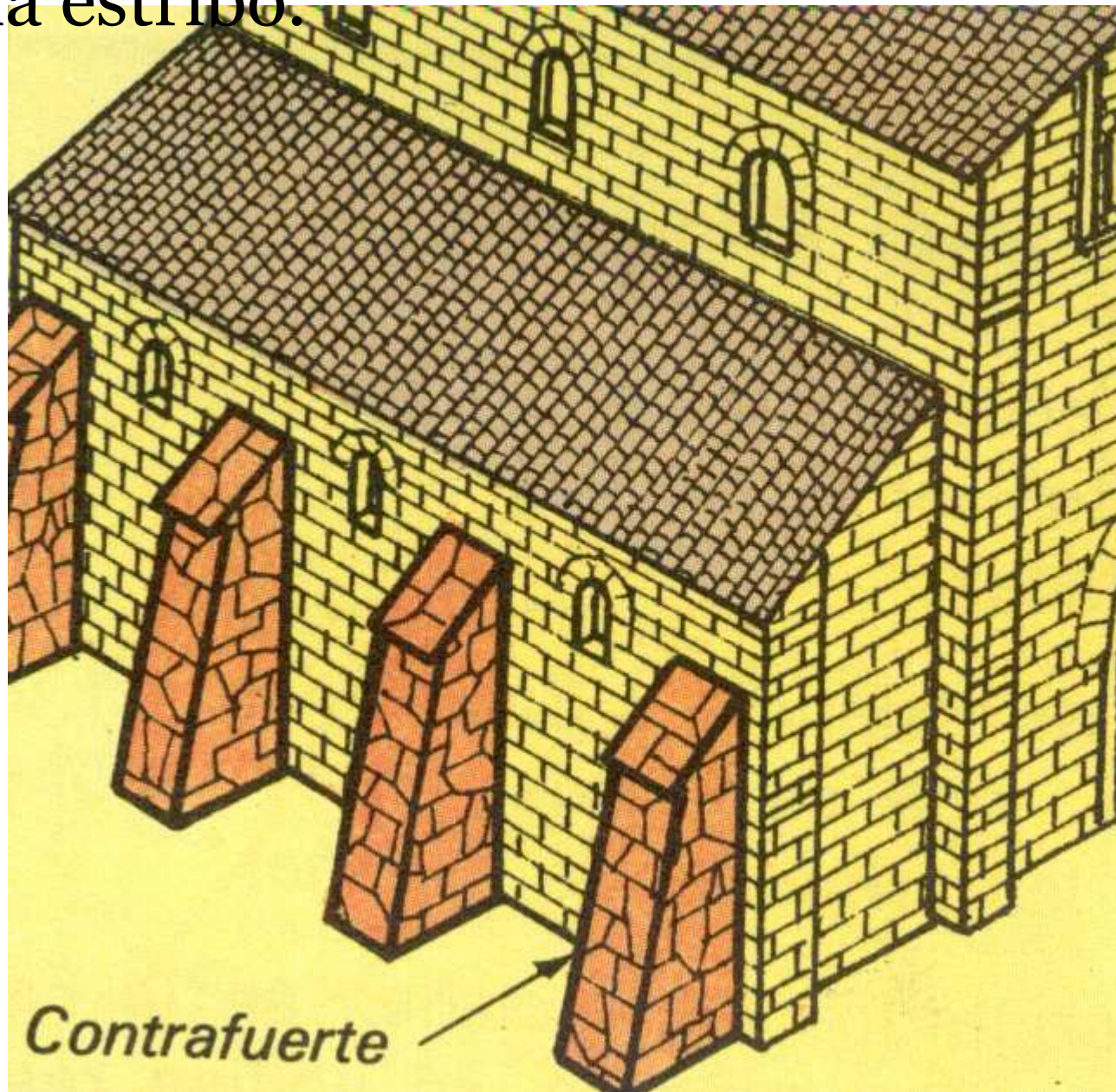
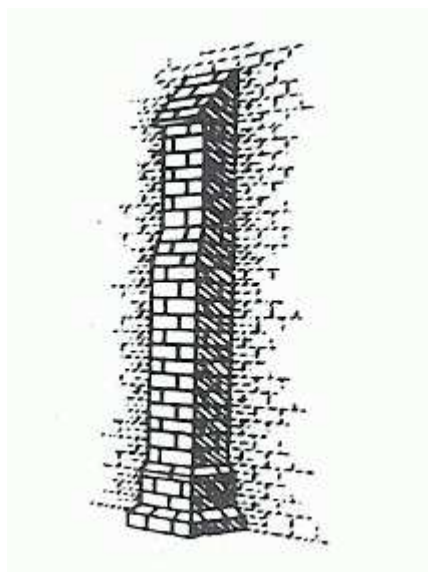





CORNIXA remate ou reborde dun muro constituído por unha peza volada totalmente independente do tellado, sostida as veces por ménsulas. Oponse o aleiro (prolongación das vigas da techume, para protexer gran parte do muro das precipitacións).





CÚPULA OU BÓVEDA ESFÉRICA abovedamento elevado sobre unha planta circular, con forma generalmente de media esfera. Tamén se chama “de media laranxa”. Pero tamén pode elevarse sobre unha planta poligonal, non resultando entón esférica, senon que a integración de varios panos curvos, que reciben o nome de panos, cascos ou elementos. O paso da planta cadrada á circular sobre a que se asenta a cúpula, pódese facer por medio de *trompas* (bóveda semicónica) ou por *pechinas* (triángulos esféricos).

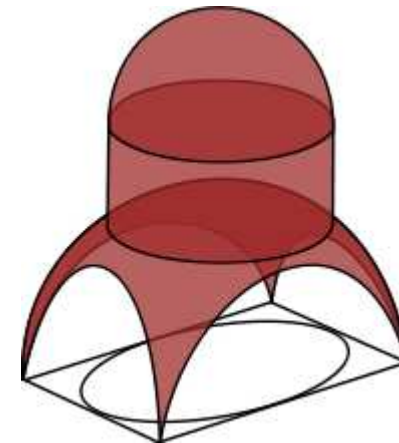
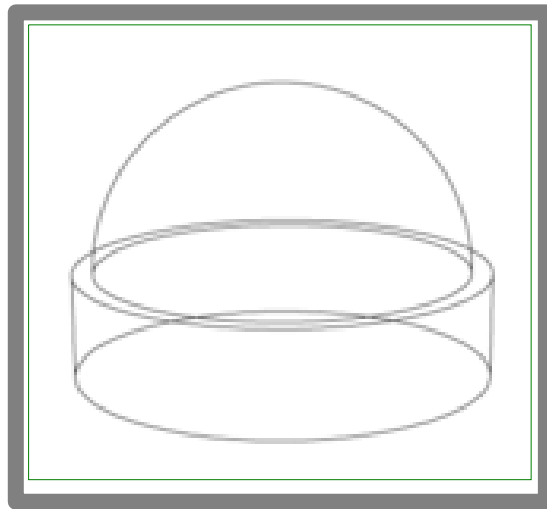



CÚPULA SOBRE PECHINAS (Pechina) Triángulo de lados curvados que, en número de cuatro, sirve para a sustentación de unha cúpula, que se levanta sobre un espacio de planta cuadrada.

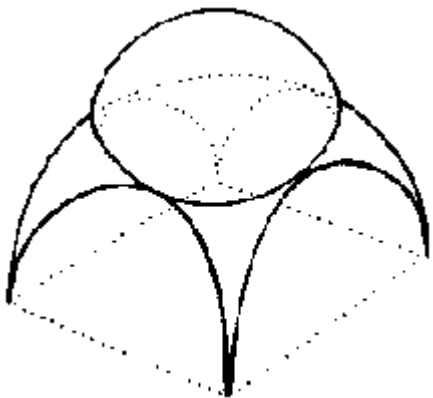
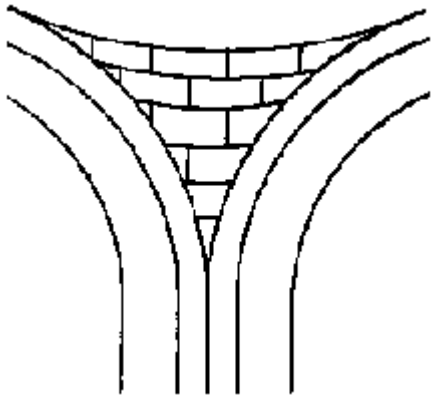



CÚPULA SOBRE TROMPAS (TROMPA) Pequena bóveda salediza que apoia o seu vértice no ángulo dos muros continuos. O emprego de catro trompas permite pasar en altura da planta cadrada á octogonal e, con elo, á cubierta de

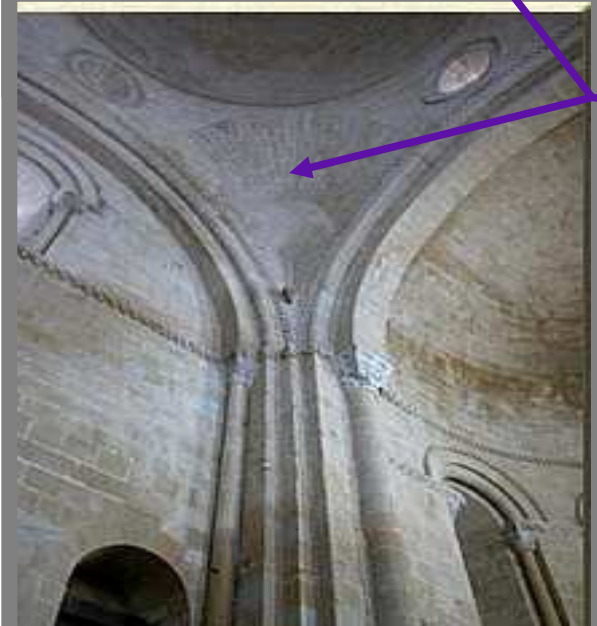
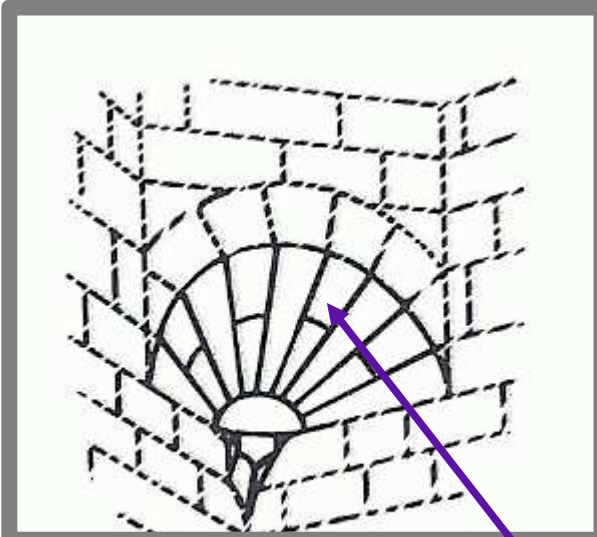

TROMPA

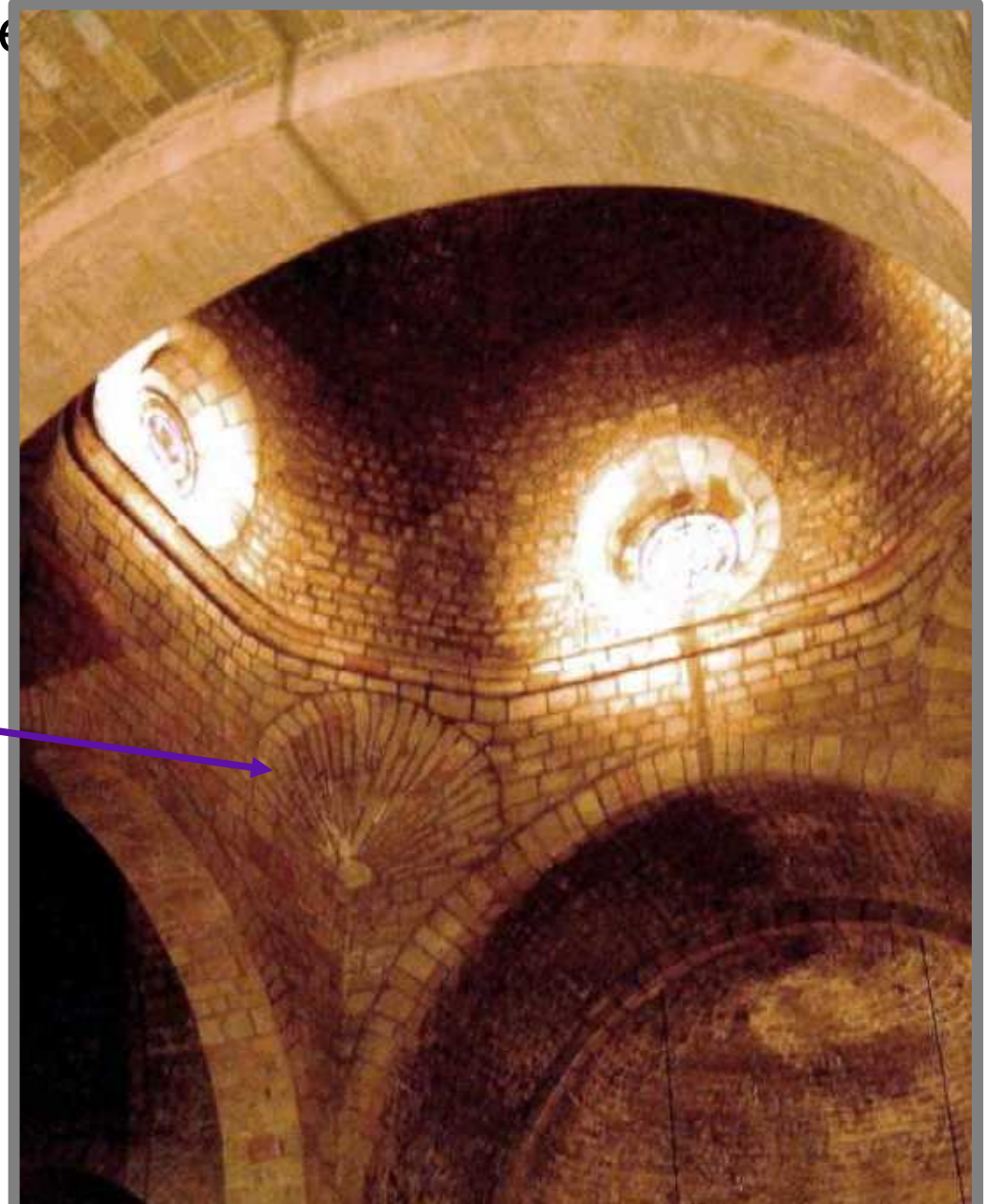



DEAMBULATORIO ou Xirola nave que circunda o altar maior

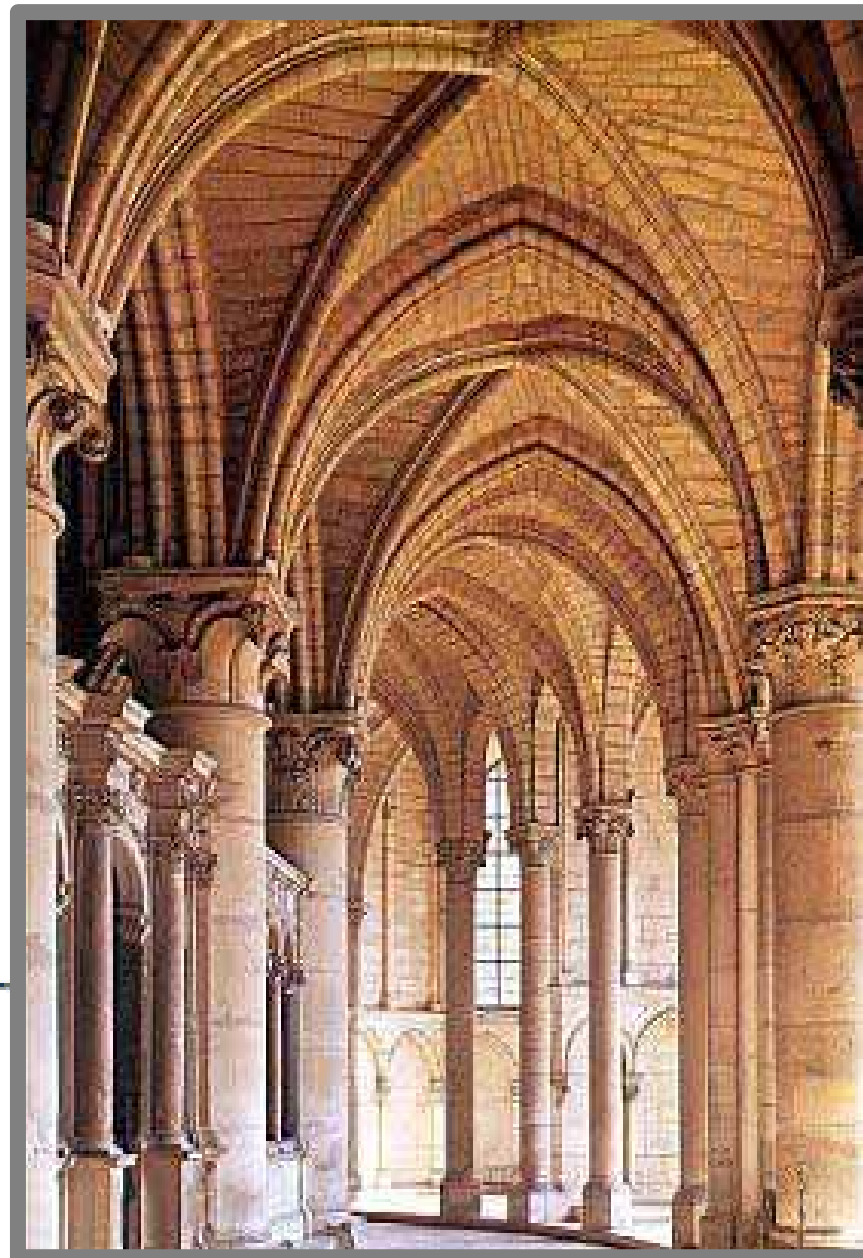
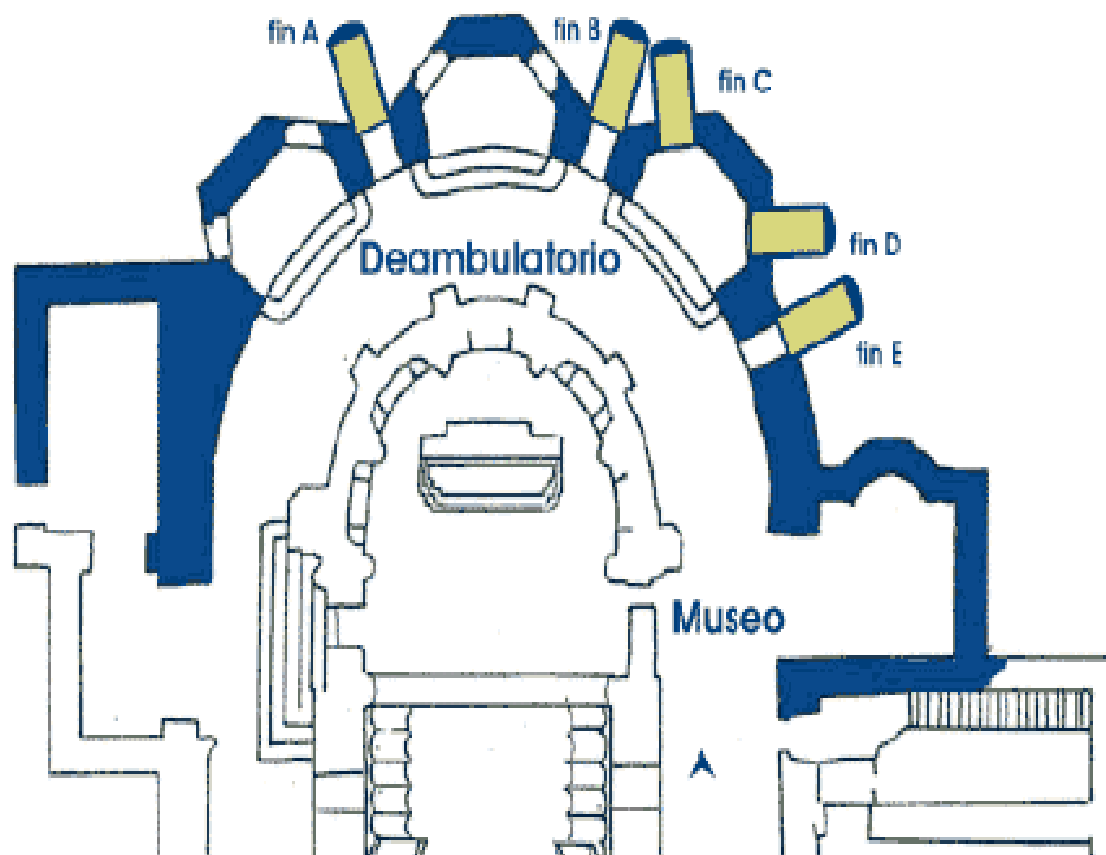



ESCULTURA DE VULTO REDONDO É aquela que se pode contemplar desde calquer punto de vista o seu arredor. Se se representa a figura humana denomínase estatua. Se a estatua representa a un personaxe divino ou está feita para o culto relixioso denomínase imaxe. En función da parte do corpo representada, a escultura de vulto redondo clasifícase en:

- **busto:** si representa a cabeza e a parte superior do tórax, de medio corpo, de tres cuartos, de corpo entero;
- **torso,** si falta a cabeza, pernas e brazos.

En función da súa posición a escultura clasifícase en:

sedente: sentada,
xacente: tumbada,
orante: de rodillas,
oferente: ofrecendo presentes,
ecuestre: a caballo



ESTATUA-COLUMNA columna cun fuste formado por unha estatua.





FRISO banda ou franxa lonxitudinal como remate dunha parede ou para estruturación ou adorno da mesma; xeralmente con ornamentos e figuras en relevo, pero tamén pintados, sobre todo en interiores. Nas órdenes clásicas gregas sitúase entre o arquitrabe e a cornisa.

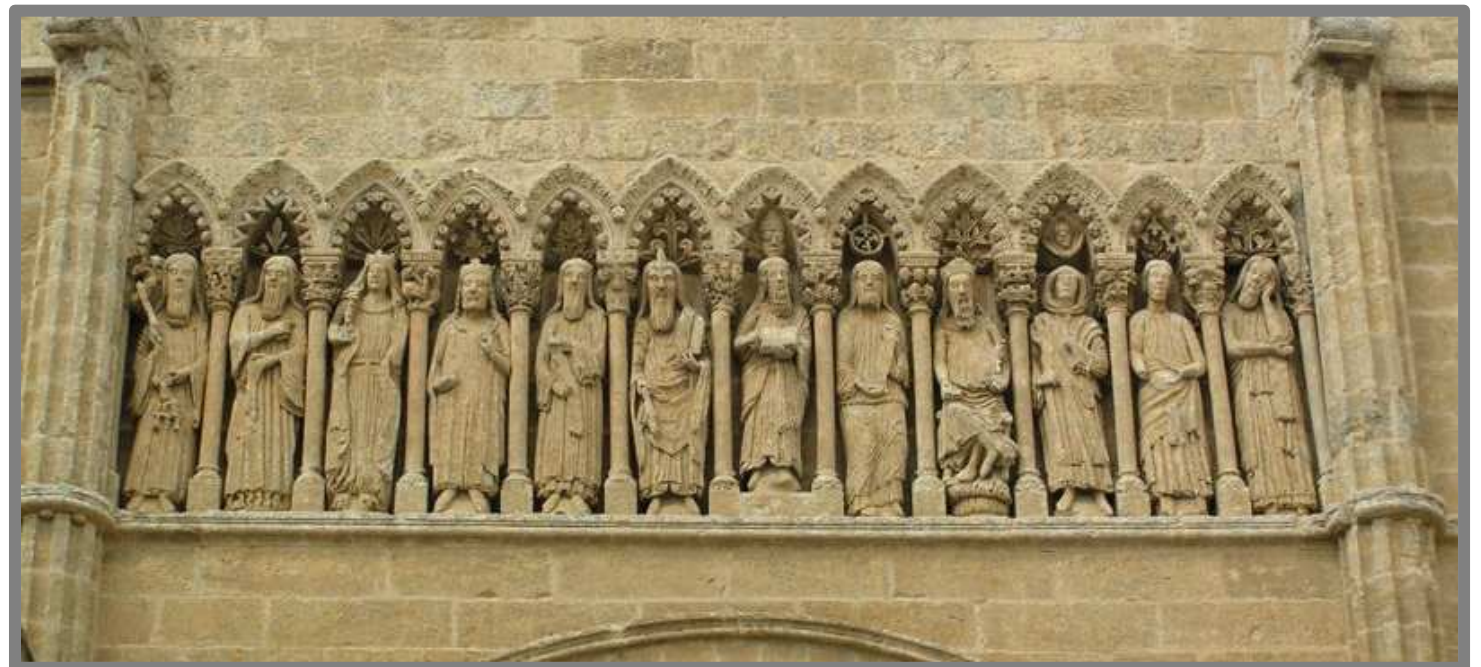



ICONOGRAFÍA (do grego= descripción de imaxes). Ciencia que estudia a orixe, formación e desenrolo dos temas figurados no tempo e nos diversos ámbitos culturais.

Descrición do contido e significación de obras de arte plásticas, en contraposición á análise formal e estilístico.



ICONOGRAFÍA DA CONSTRUCCIÓN



MÉNSULA: Elemento sustentante que non chega ó chan, sobresaínte respecto ó plano vertical, que se emplea para sostener a outro plano



ménsula





METOPA Na orde dórica, espacio situado no friso, entre dous triglifos. Soe decorarse con relevés.





MODERNISMO: A arquitectura modernista desenvolveuse en Europa entre 1890 e 1910 alí onde existía unha burguesía enriquecida e refinada que necesitaba un arte máis elegante e de maior calidade que o ofrecido polos historicistas ou polos inxeneiros do ferro e do cristal. Isto vai unido a unha revitalización de certo espírito romántico que defende a fantasía creadora, reivindica a subxetividade e recupera a idea de que as artes deben proporcionar goce e placer. A linguaxe modernista pretende imitar as formas da natureza, cun claro predominio das formas curvas nas prantas e fachadas e unha abundante decoración inspirada en formas de seres vivos, despregada polos muros, teitos e portas; Dentro da arquitectura modernista existiron dúas tendencias: as formas sinuosas, ondulantes e orgánicas, por un lado; e as xeométricas e abstractas, precursoras da futura arquitectura racionalista, por outro.





NÁRTICE ou Nartex nave transversal a entrada dunha igrexa.



Nartex





PARTELUZ: elemento vertical que divide en dous un vano.

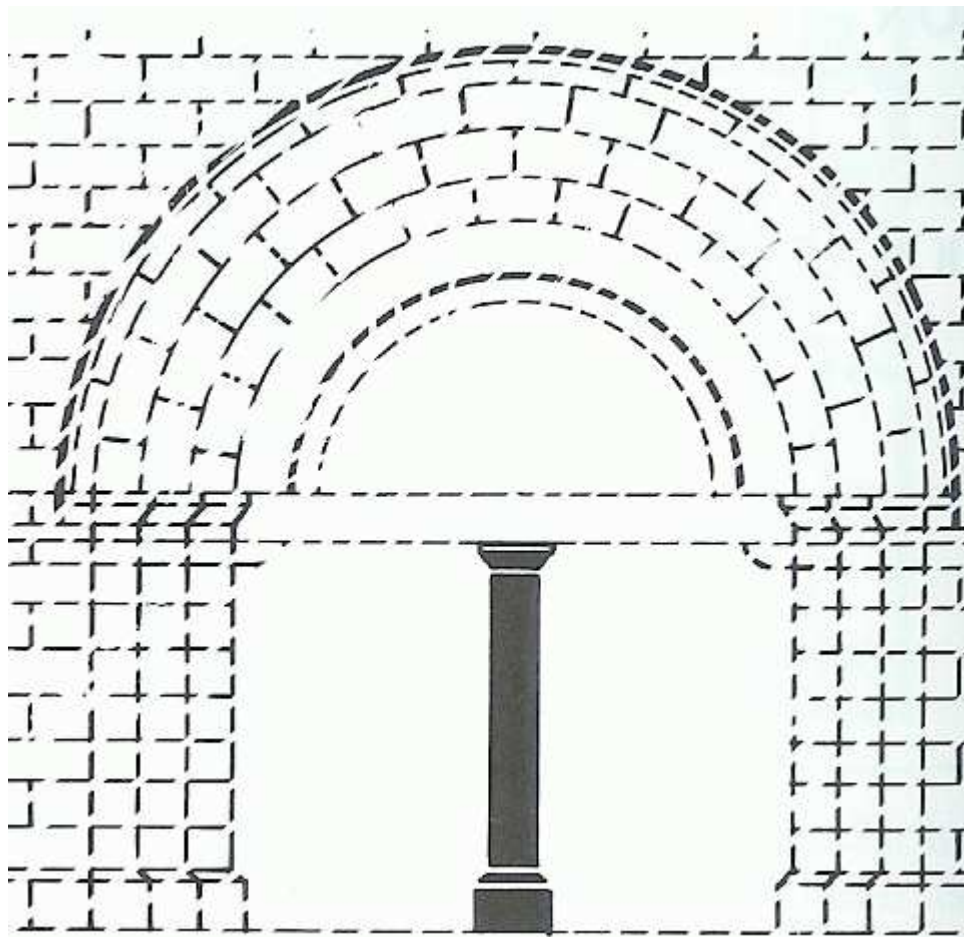



PICTÓRICO Adecuado para ser representado en pintura

Releve pictórico é o que se logra polo efecto ilusionista da profundidade espacial. Conseguida pola colocación de planos de relevés continuos, pero realizados con diferentes grados de resalte.





PIAR soporte exento, de planta cadrada ou poligonal. o piar pode ter os mesmos elementos que a columna (basa, fuste e capitel) e suxetarse a todas as ordes clásicas.

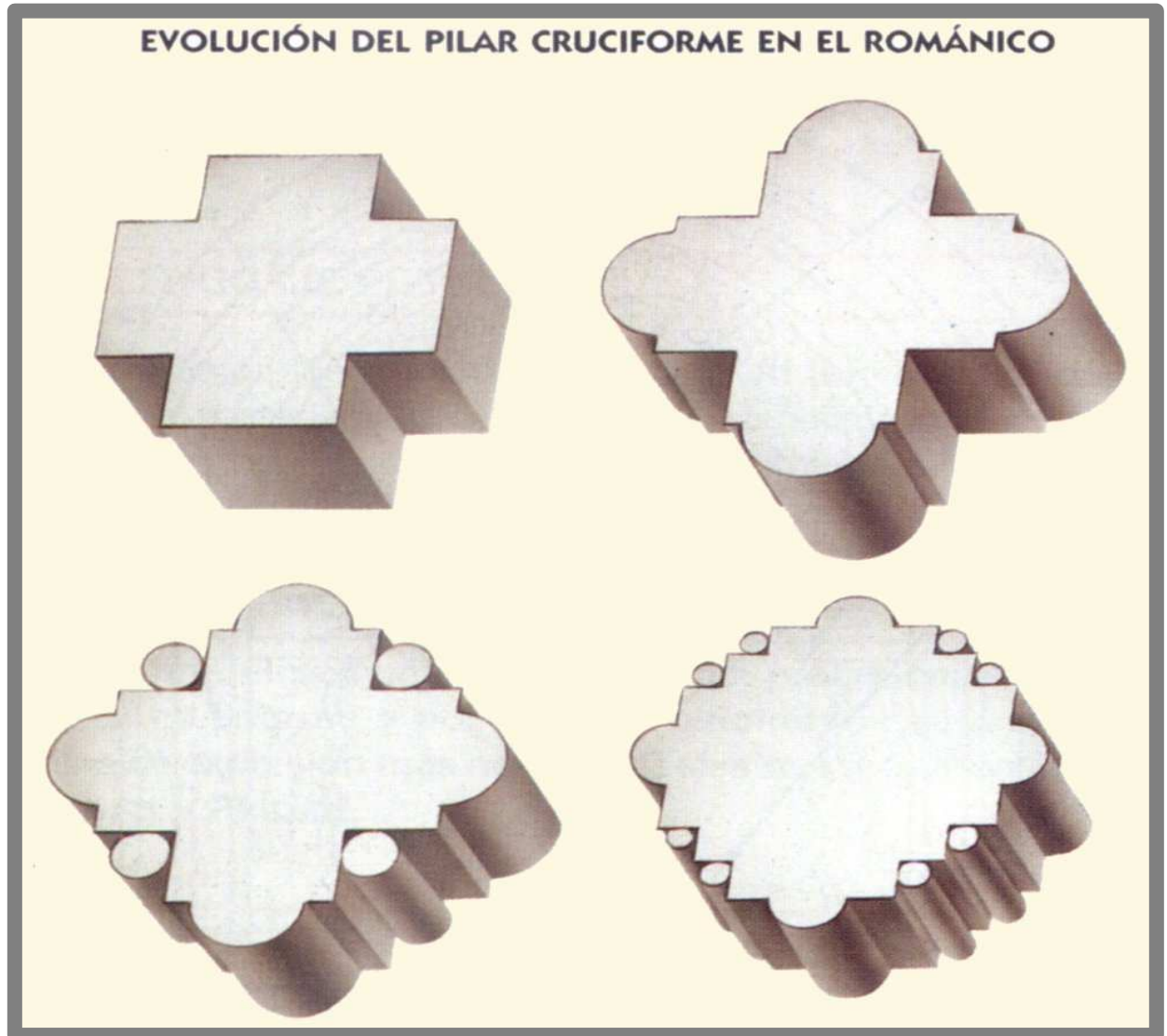



PILASTRA pilar adosado ou embebido parcialmente no muro.





PLAN CENTRAL planta de tradición oriental de disposición circular, poligonal ou cadrada.

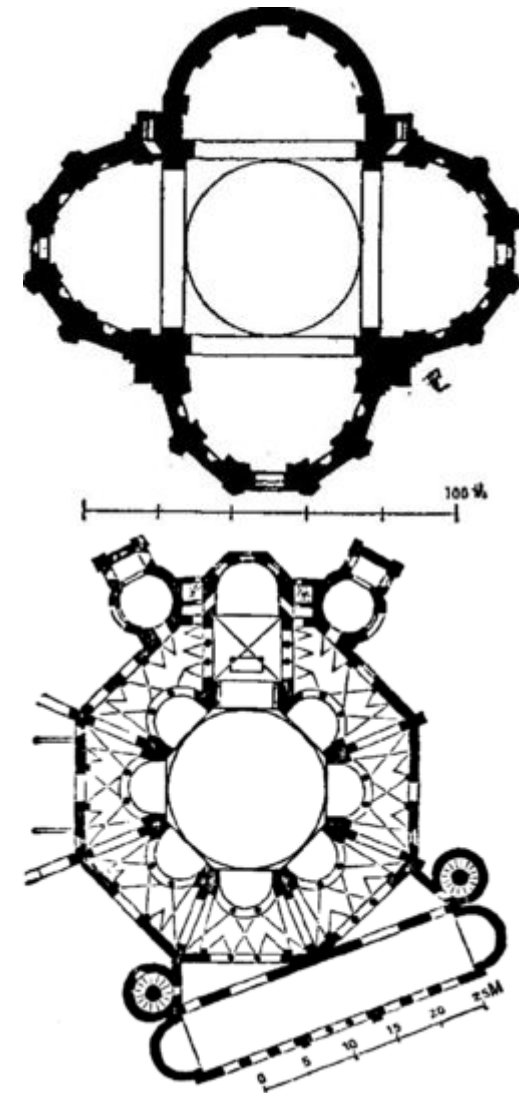



PLAN BASILICAL planta de tradición occidental, inspirada nas basílicas romanas. Consta dun gran salón alongado, dividido en tres ou máis naves, separadas por columnas. Ó fondo da principal, que sempre era maior cas demais, ubicábase a ábside.

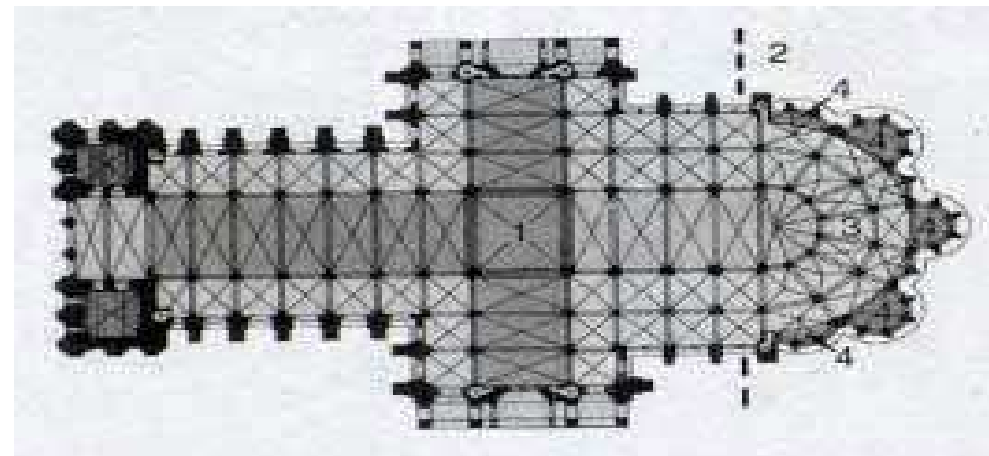
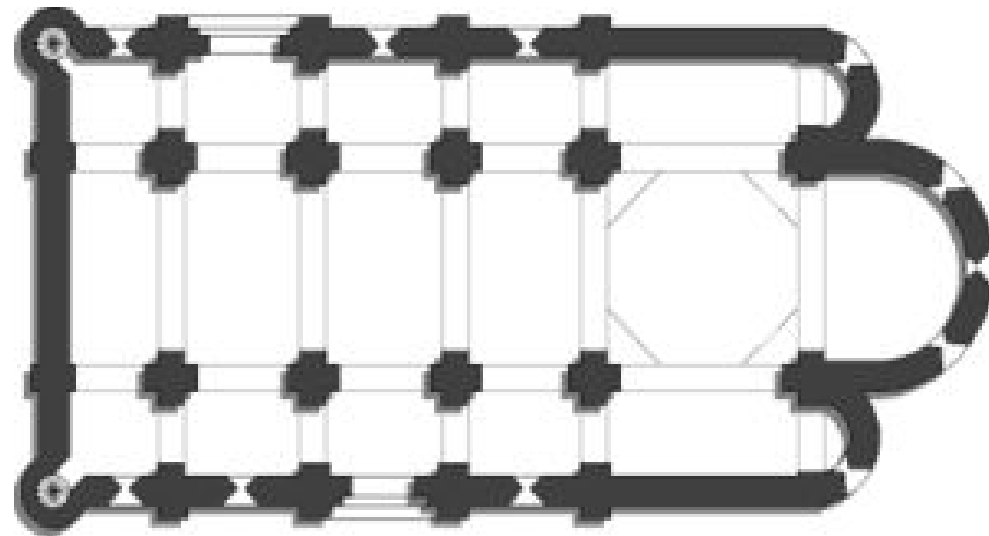



PLANTA DE CRUZ GREGA planta en forma de cruz de brazos iguais.

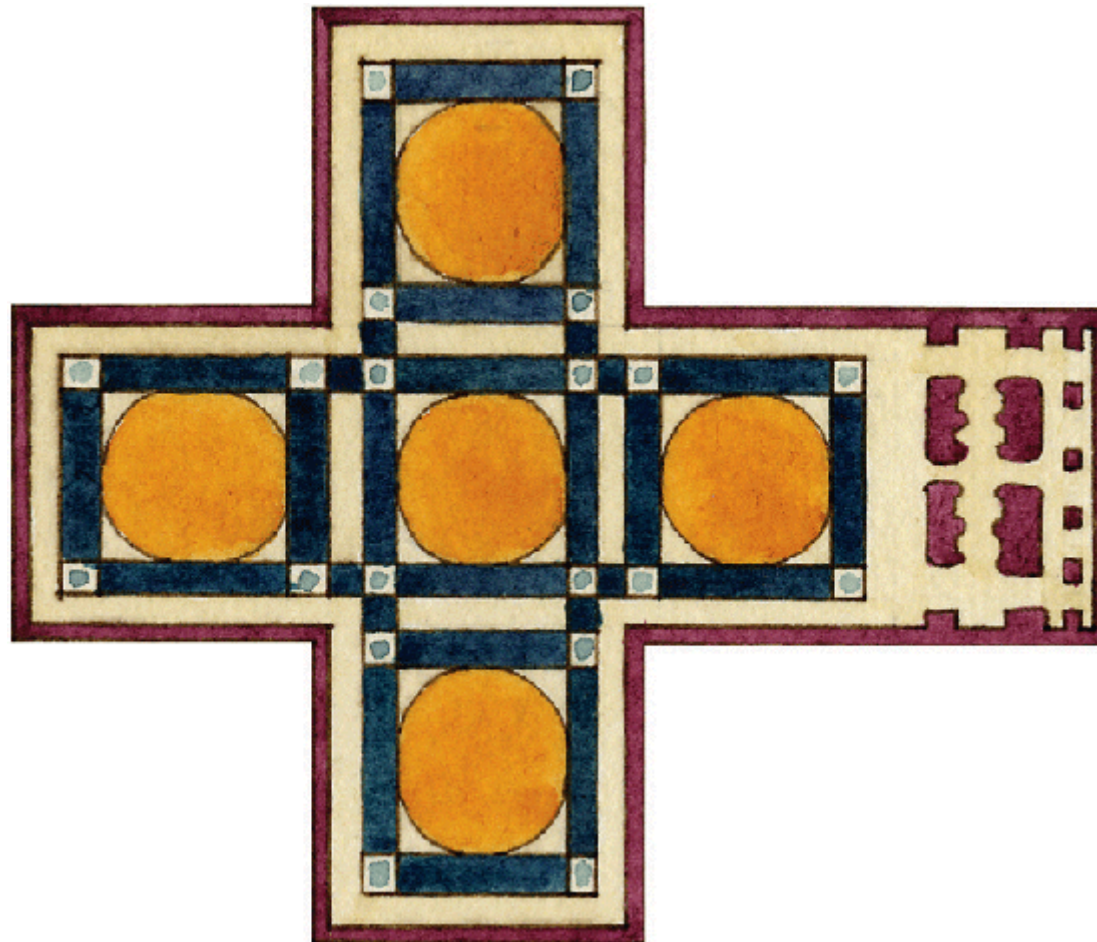



PLANTA DE CRUZ LATINA planta en forma de cruz de brazos desiguais.

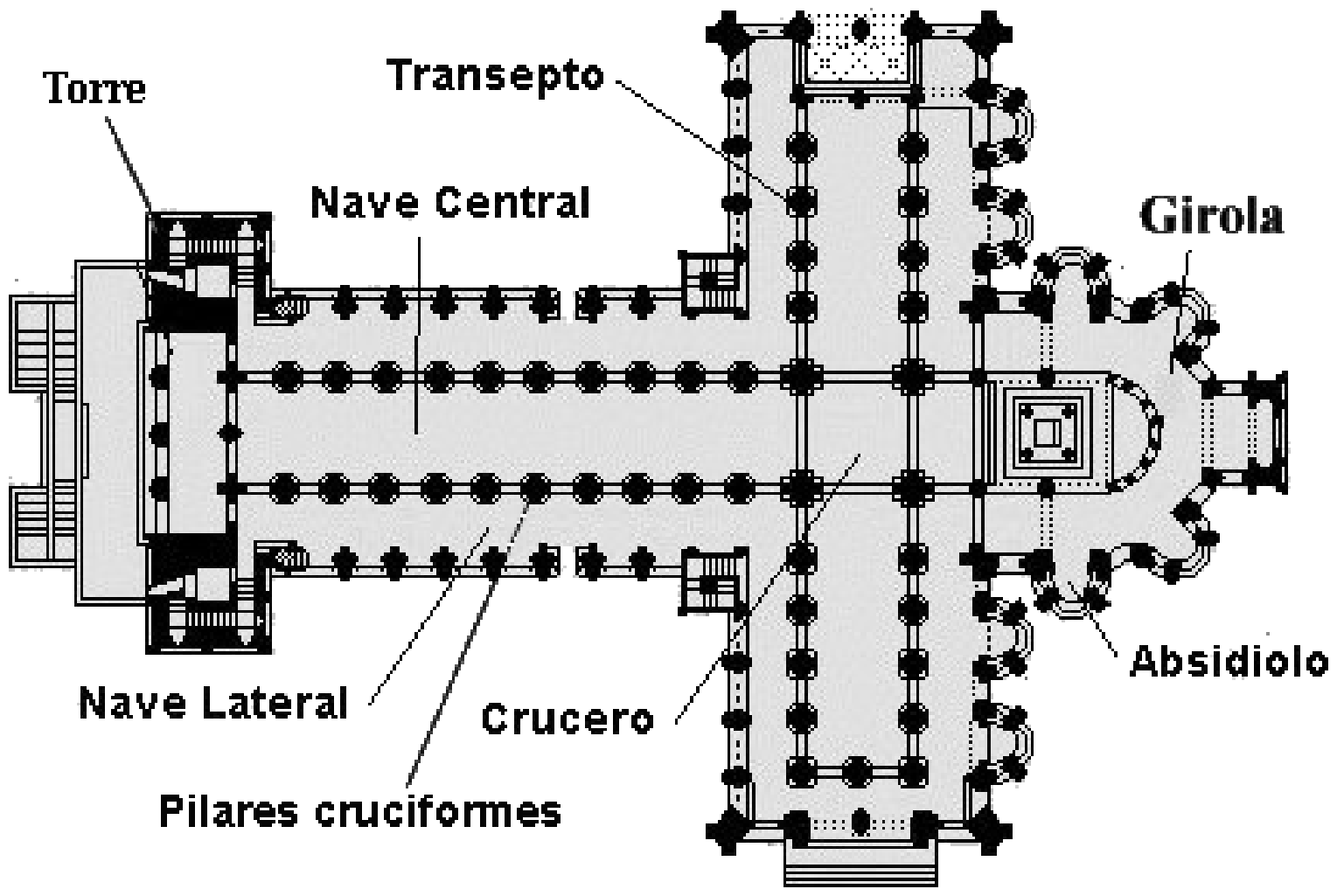



PLÁSTICO (relevo) é o que procura un efecto esencialmente escultórico, é dicir, fai resaltar o vulto sen preocuparse do efecto de distancia e do ambiente en que vive a figura, que é o que se persegue no relevo pictórico.





PRESBITERIO sector do templo cristián en torno ó altar.





RETABLO: estrutura, normalmente de madeira, coa que se decora a cabeceira dunha igrexa ou as súas capelas laterais, tralos respectivos altares, e na que figuran esculturas e/ou pinturas de temática relixiosa.

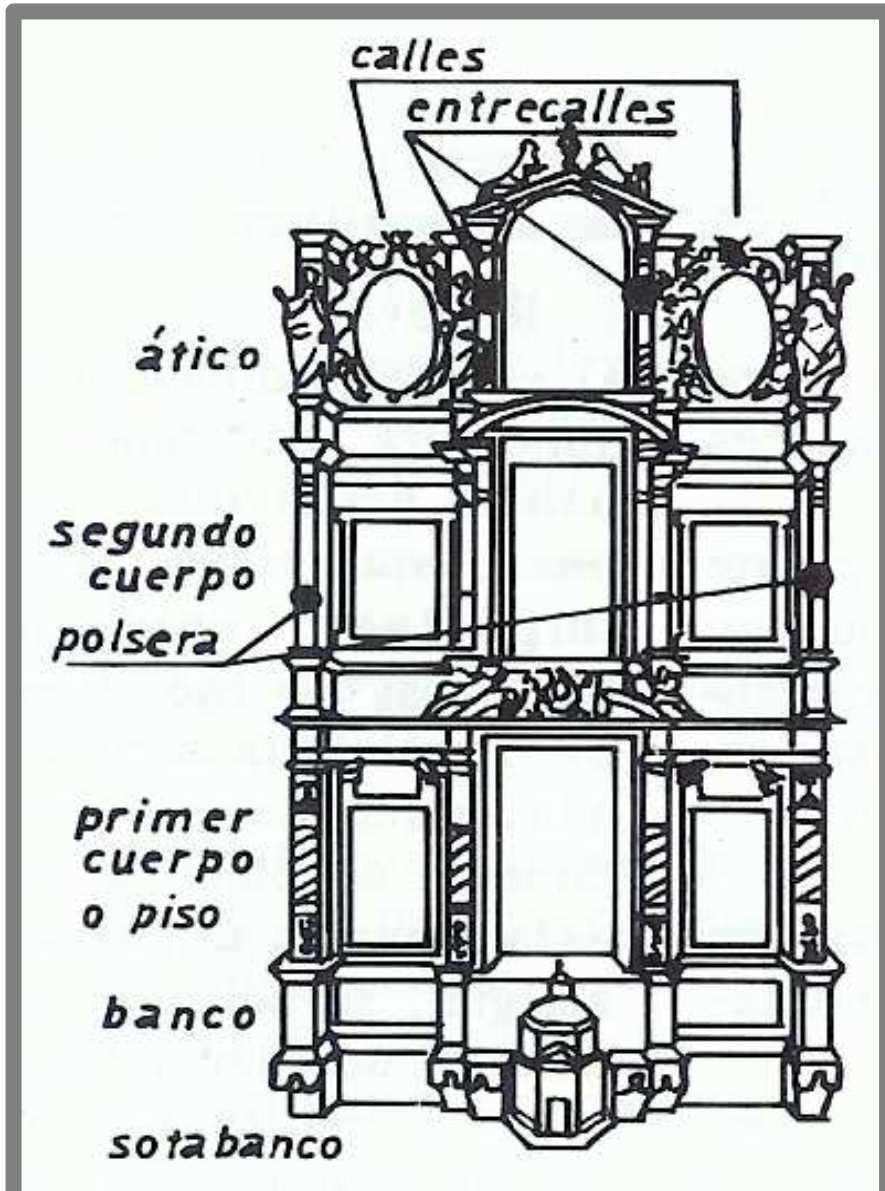

Románico

- A **Arte románica** foi o estilo artístico predominante en Europa nos séculos **XI, XII, e parte do XIII**.
- O románico **agrupa** as diferentes opcións que se utilizaran a comezos da Idade Media (**romana, prerrománica, bizantina, xermánica e árabe**) e conseguindo formular unha linguaxe específica e coherente aplicado a todas as manifestaciones artísticas.
- Non foi producto dunha soa nacionalidade ou rexión, senón que **xurdiu** de maneira paulatina e case simultánea en **Italia, Francia, Alemania e España**.
- En cada un destes países nace con **características propias**, aínda que coa suficiente unidade como para ser considerado o primeiro estilo internacional, cun ámbito europeo.

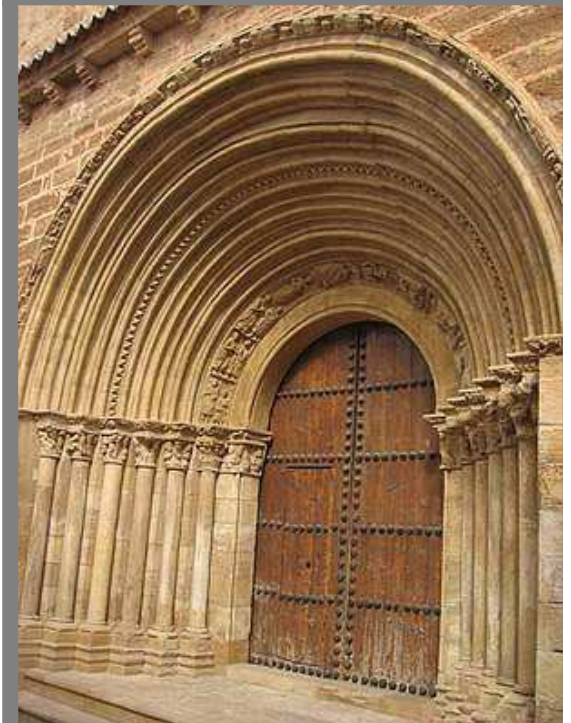



ROSETÓN: ventá con tracería, especialmente na arquitectura gótica.

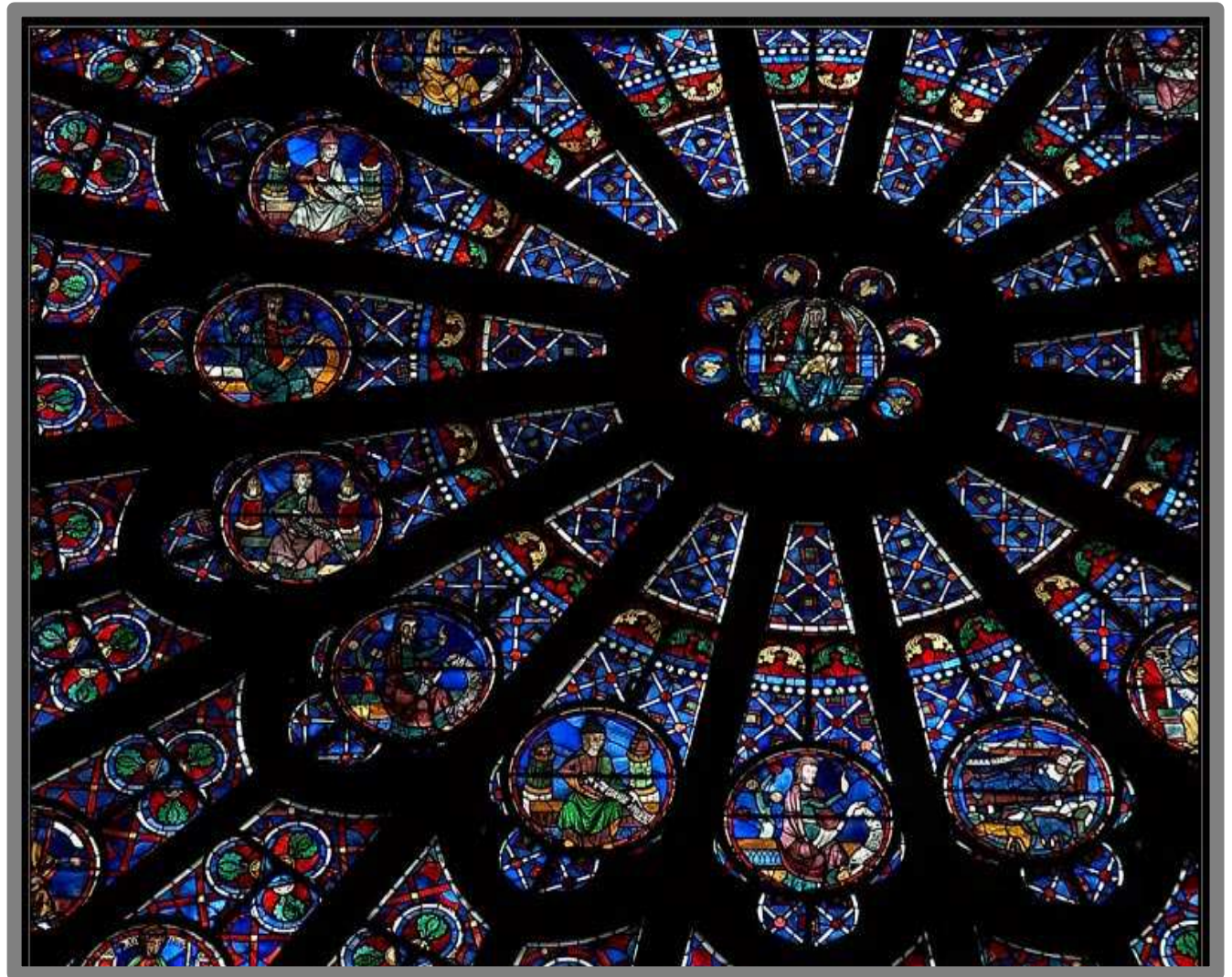



TÍMPANO :

a) Espacio interior dun frontón.

b) Espacio que, na portada dunha igrexa, extendese entre o dintel e a primeira arquivolta.

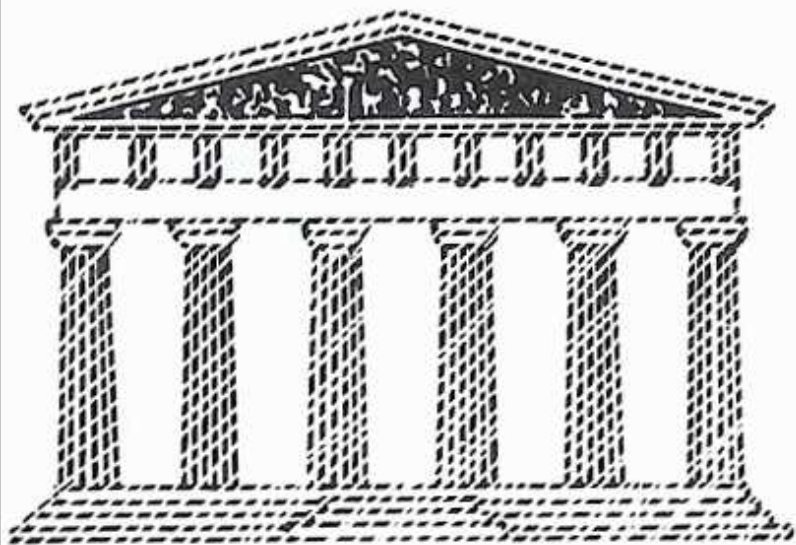

a

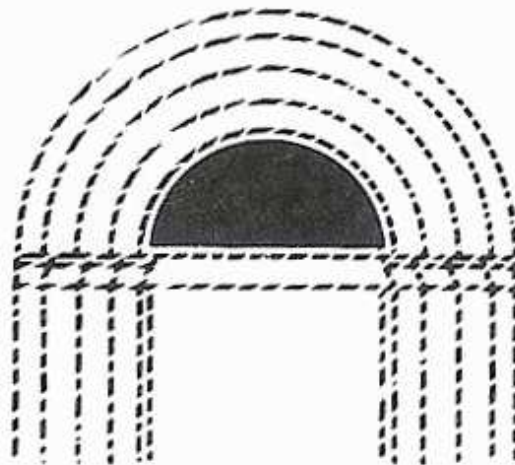

b

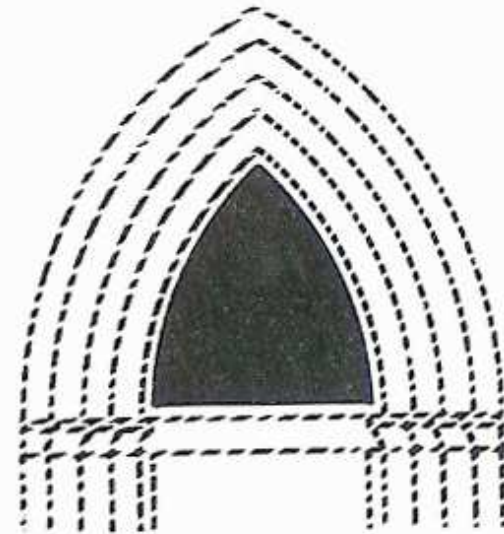

b



TRIBUNA galería situada sobre as naves laterais dunha igrexa, normalmente da mesma anchura que as naves laterais. Posúe iluminación do exterior.

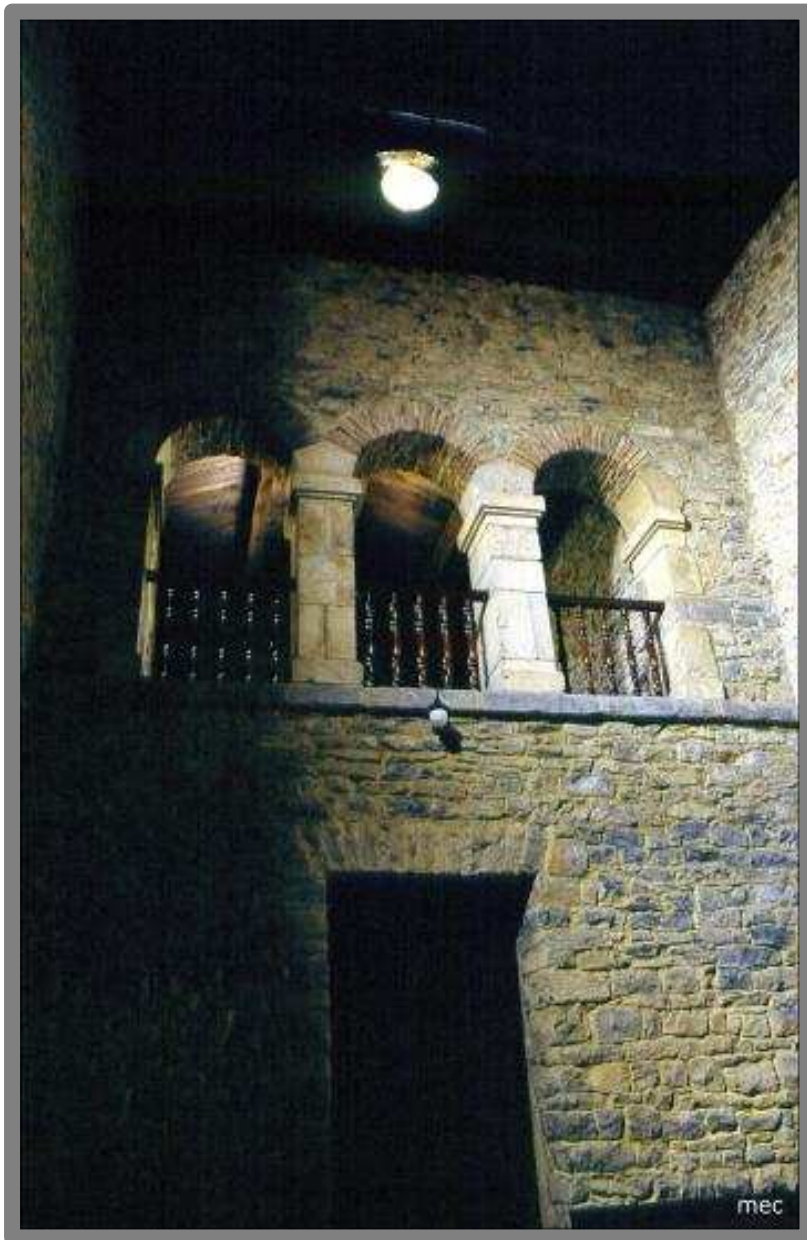



TRIFORIO serie de arcadas practicadas nos muros da nave central, da nave transversal ou do coro.





XAMBA cada un dos elementos arquitectónicos verticais que sosteñen o dintel do van.

