

Unit 1 Activity 1

Circle nine colours. Colour and write.

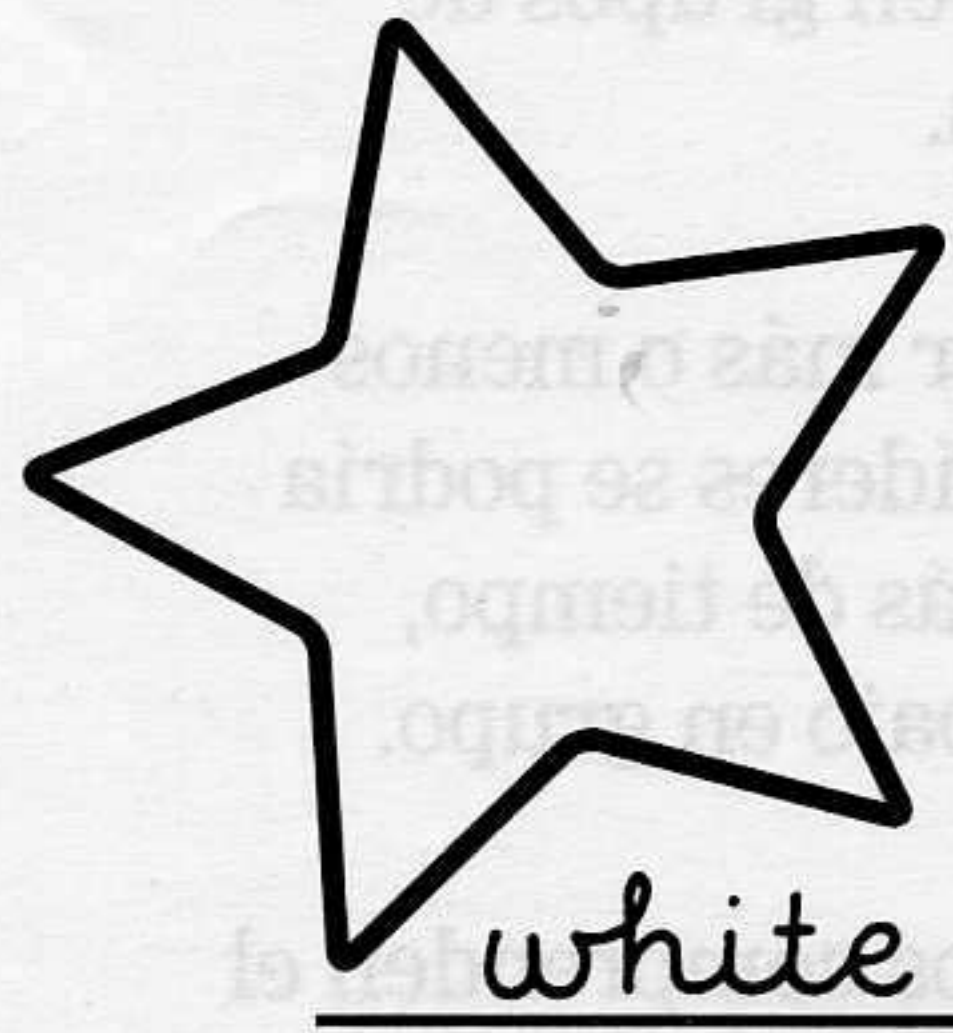

e	o	n	b	y	c	r	e	d
a	o	b	t	w	k	w	f	h
y	e	l	l	o	w	h	g	o
r	q	u	d	f	h	i	j	r
p	x	e	m	p	p	t	w	a
i	g	c	c	g	r	e	e	n
n	t	b	l	a	c	k	v	g
k	h	s	p	u	r	p	l	e
c	f	b	r	o	w	n	y	w

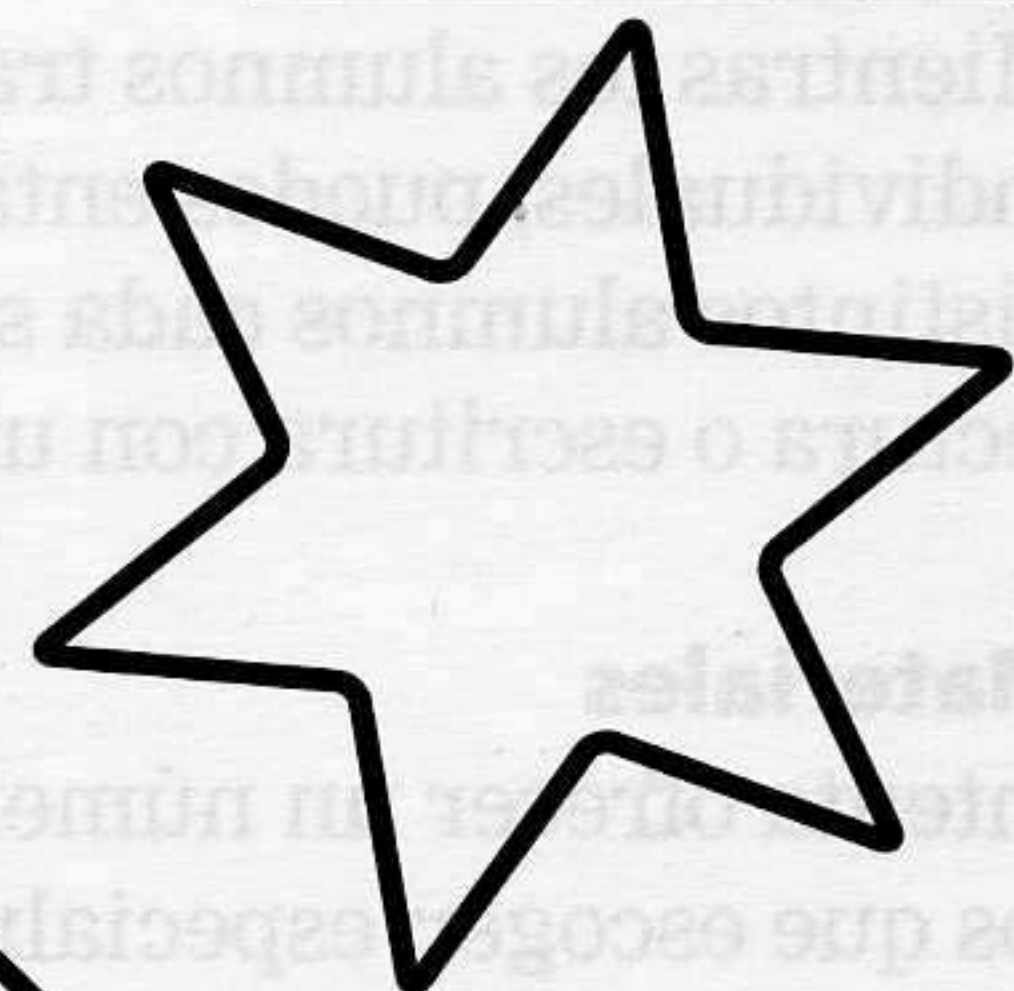
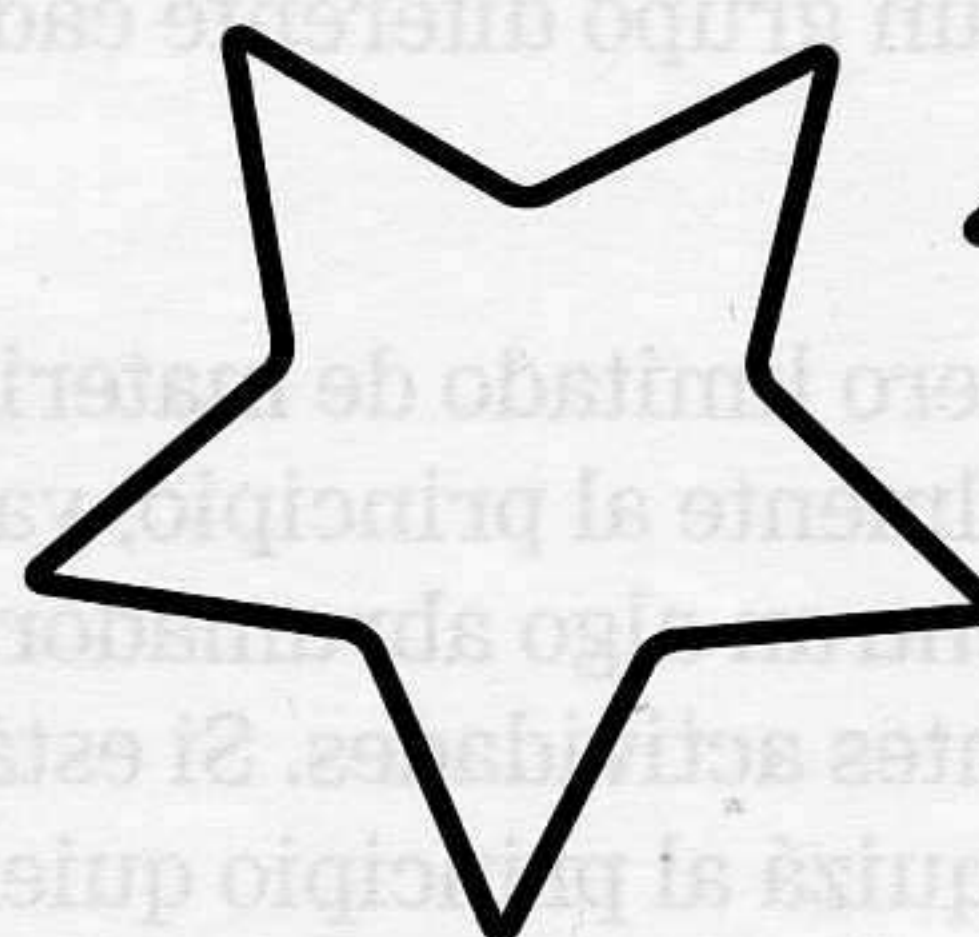
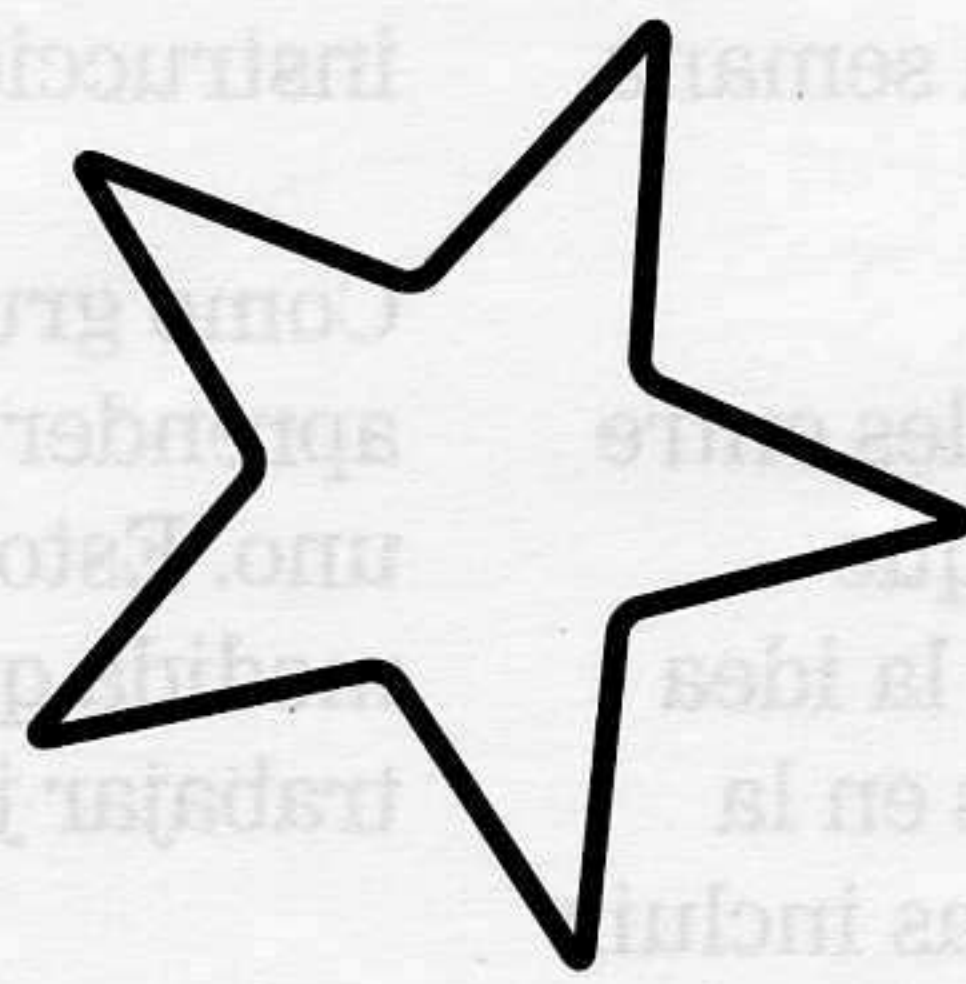
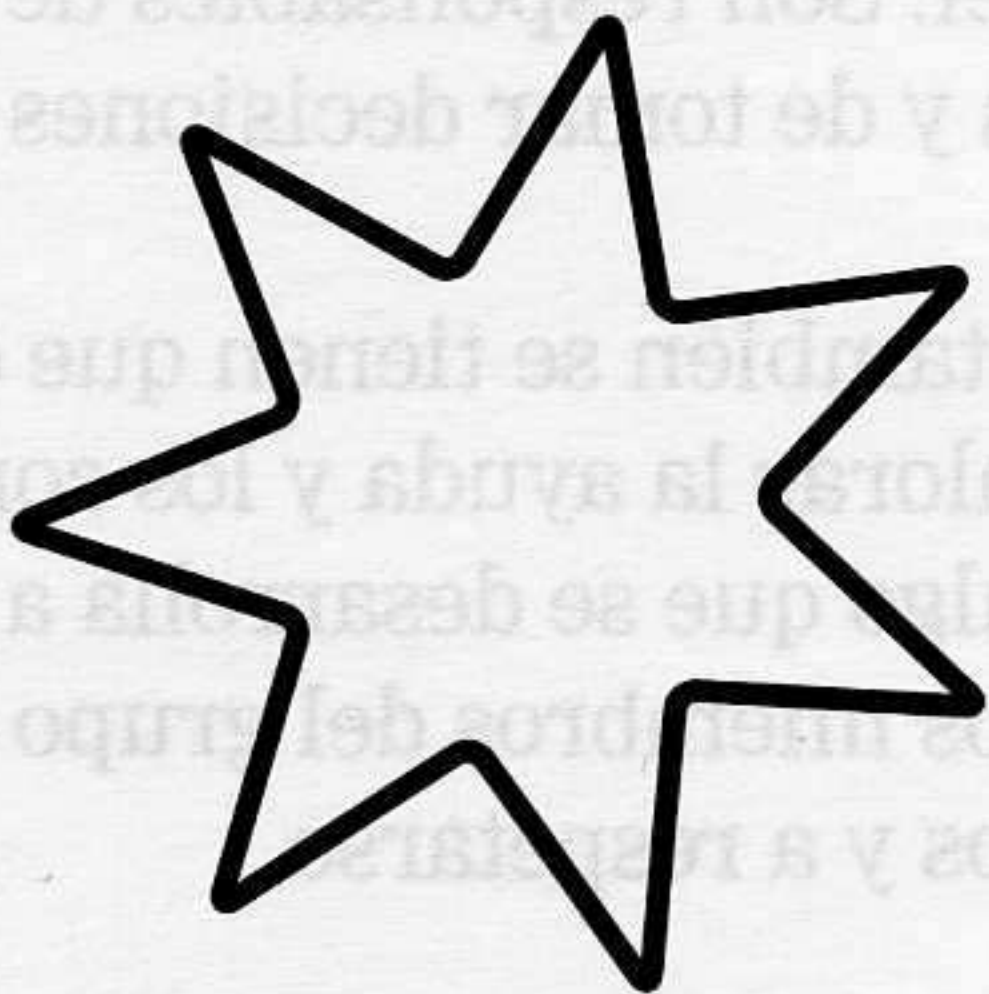
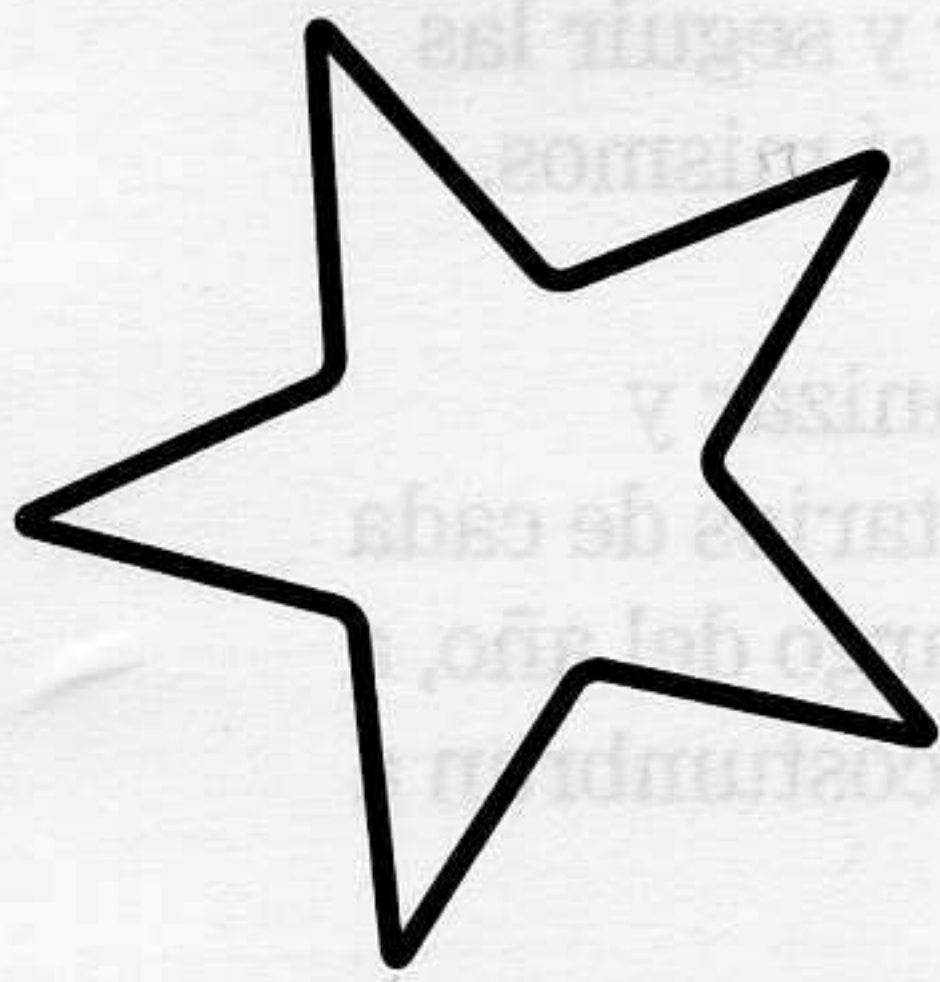
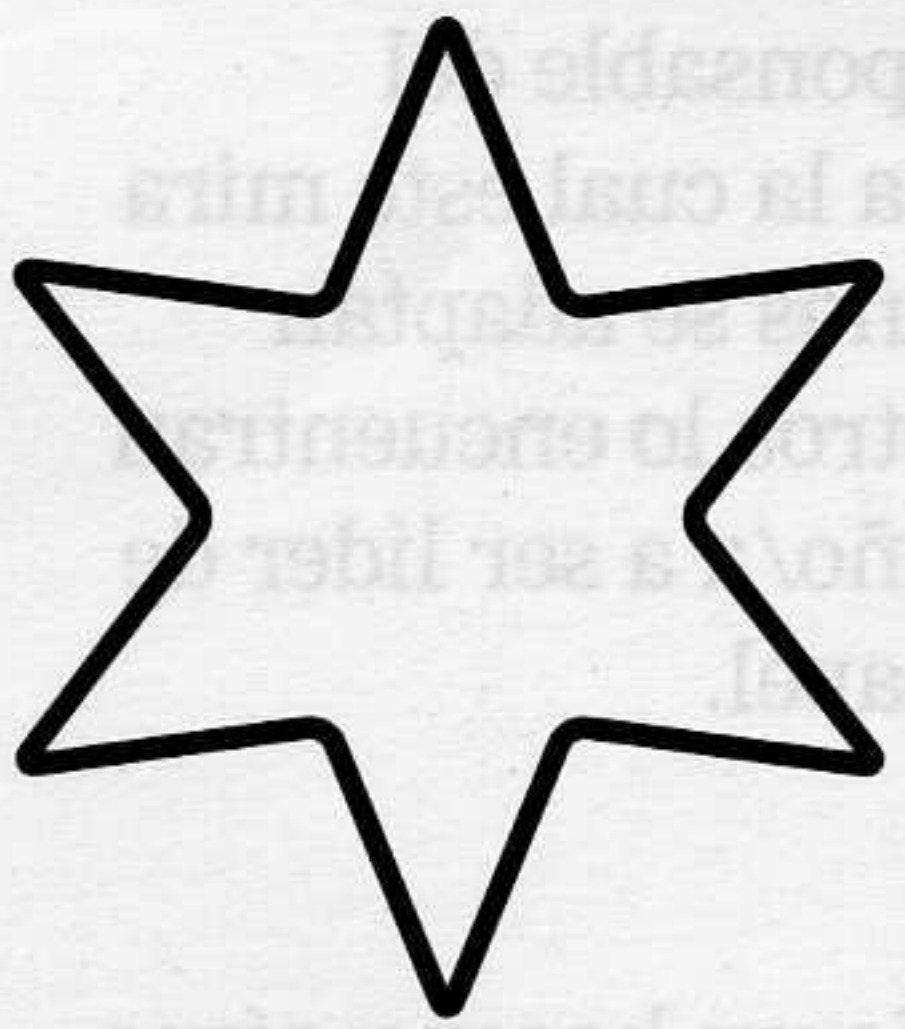

Unit 1 Activity 2

Write.

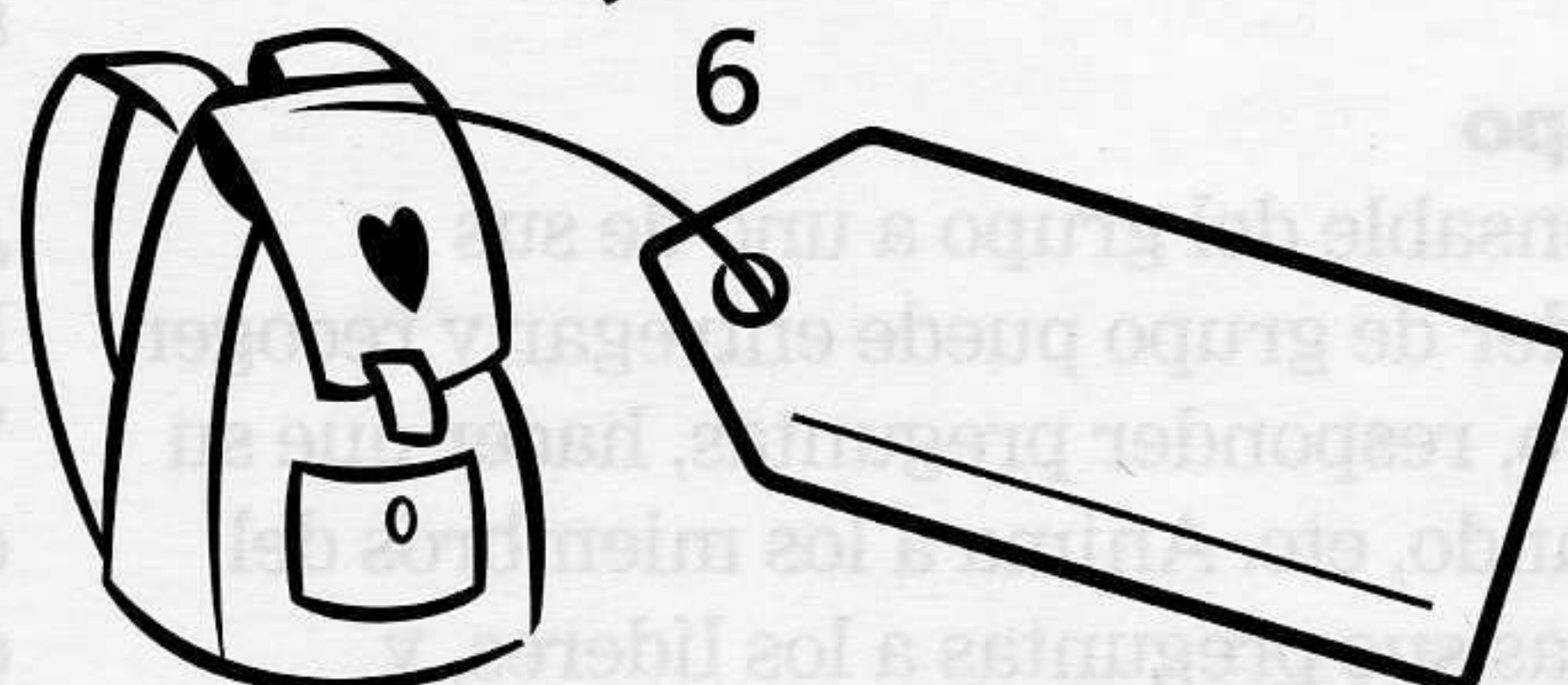
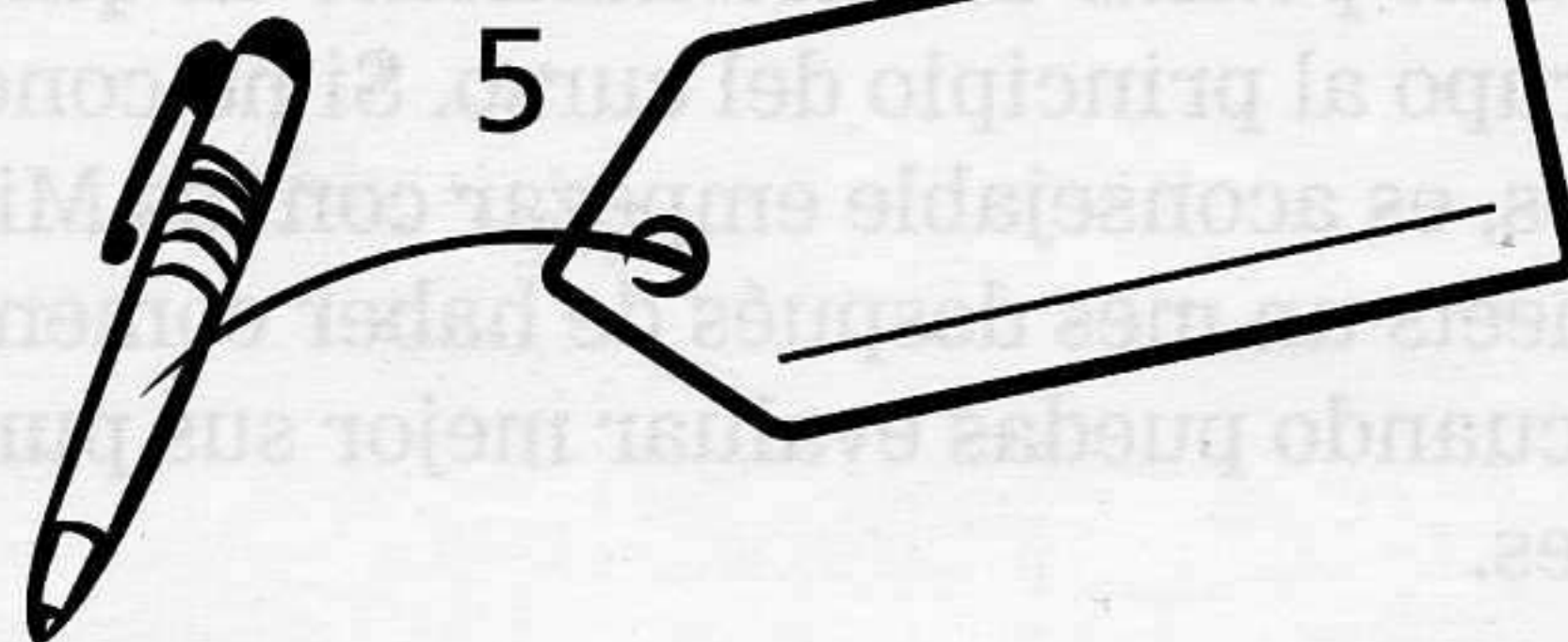
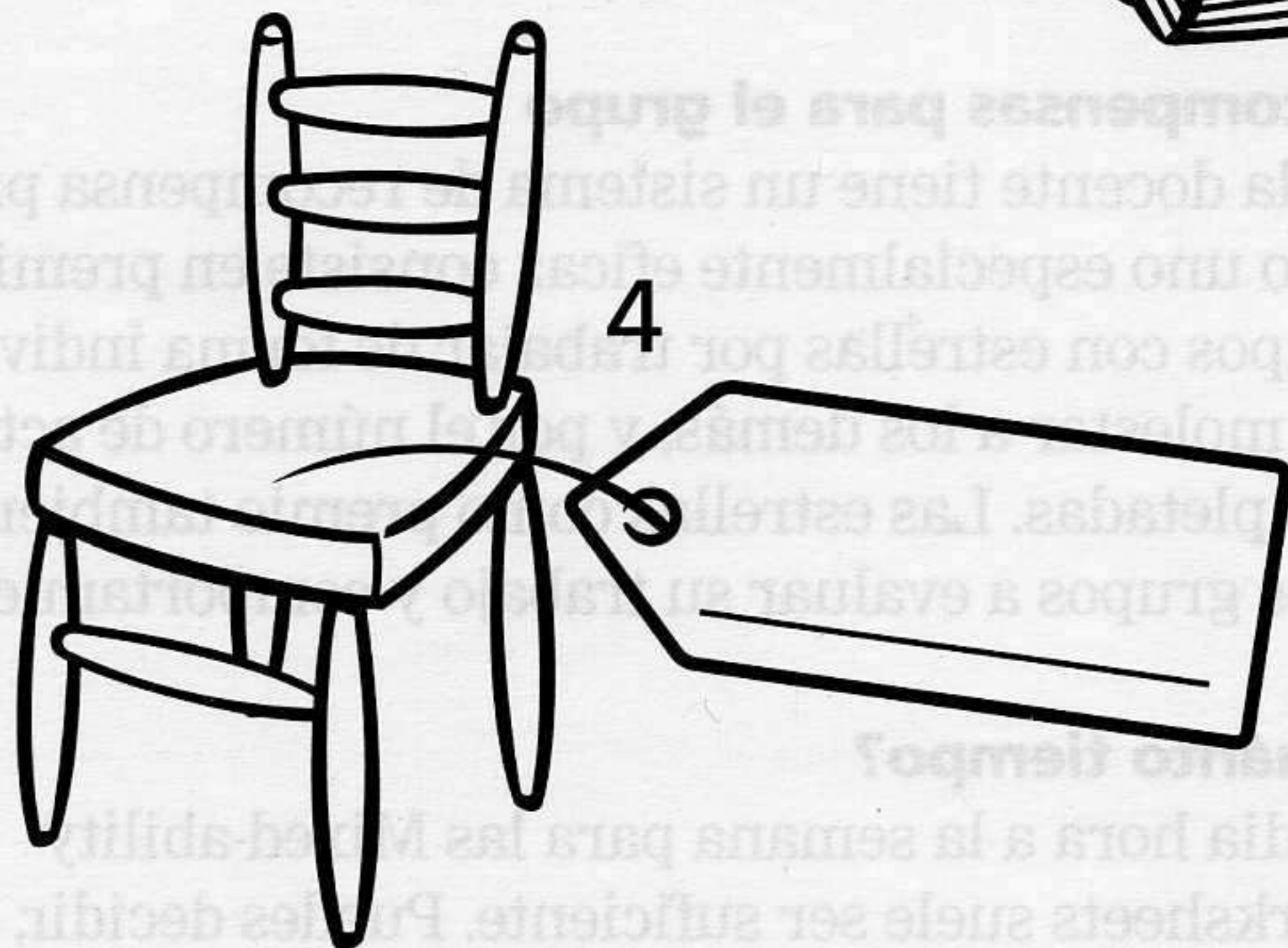
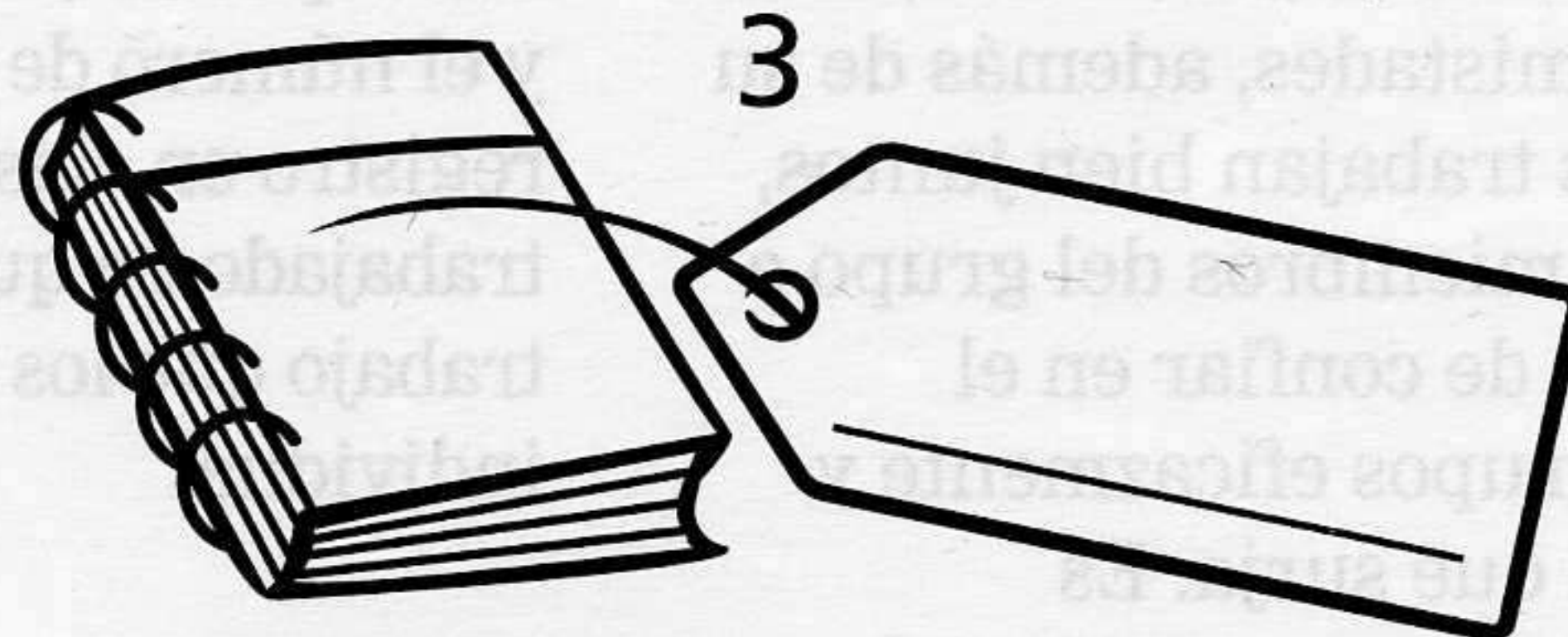
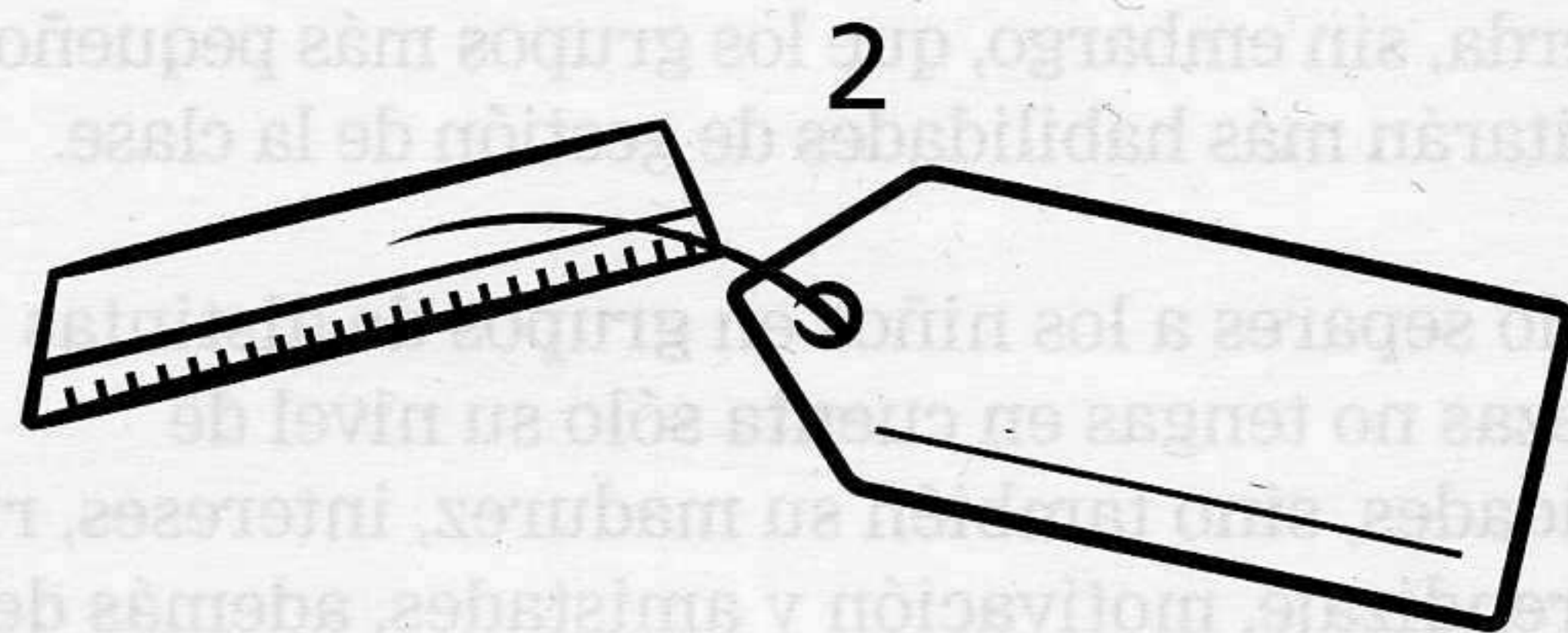
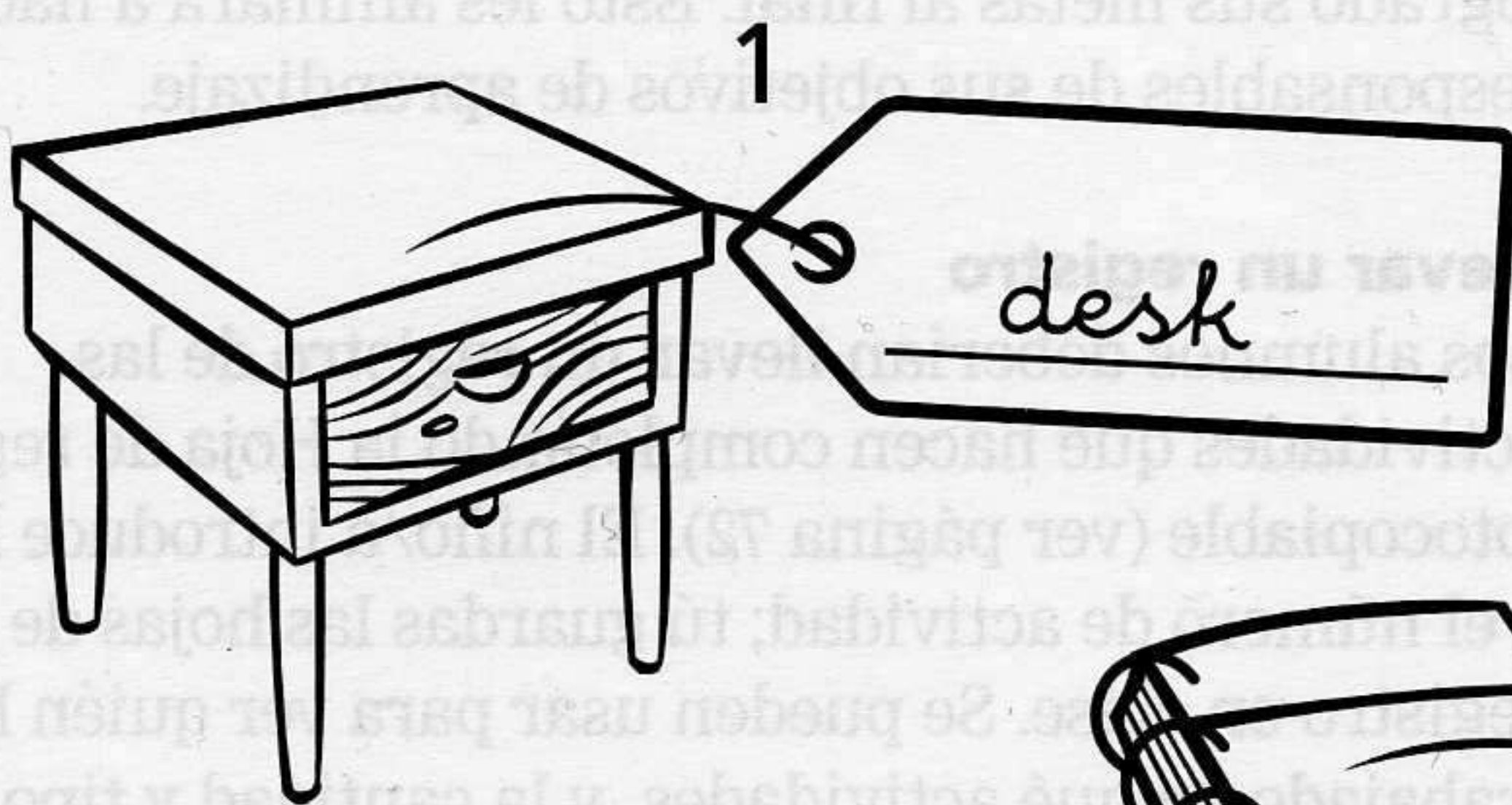

Unit 1 Activity 3

Count, read and circle true (T) or false (F).

- | | | |
|----------------------|------------------------------------|---|
| 1 three pencils | <input checked="" type="radio"/> T | F |
| 2 five rulers | <input type="radio"/> T | F |
| 3 six pens | <input type="radio"/> T | F |
| 4 ten rubbers | <input type="radio"/> T | F |
| 5 eight pencil cases | <input type="radio"/> T | F |
| 6 two scissors | <input type="radio"/> T | F |
| 7 four notebooks | <input type="radio"/> T | F |



Unit 1 Activity 4

Colour, read and write.

* blue ▲ yellow □ white ● purple X green ○ black + red

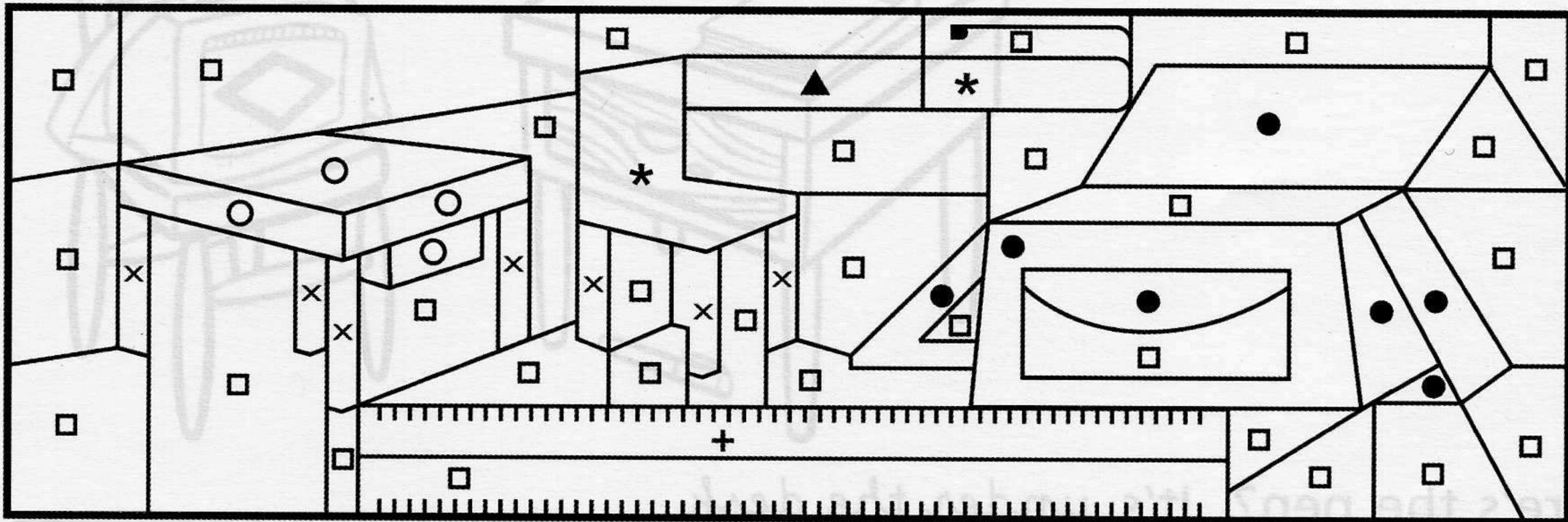

1 What is it? It's blue and yellow. It's a pen.

2 What is it? It's green and black. It's a _____

3 What is it? It's white and red. It's a _____

4 What is it? It's purple and white. It's a _____

5 What is it? It's blue and green. It's a _____

Unit 1 Activity 5

Draw. Circle the answer.

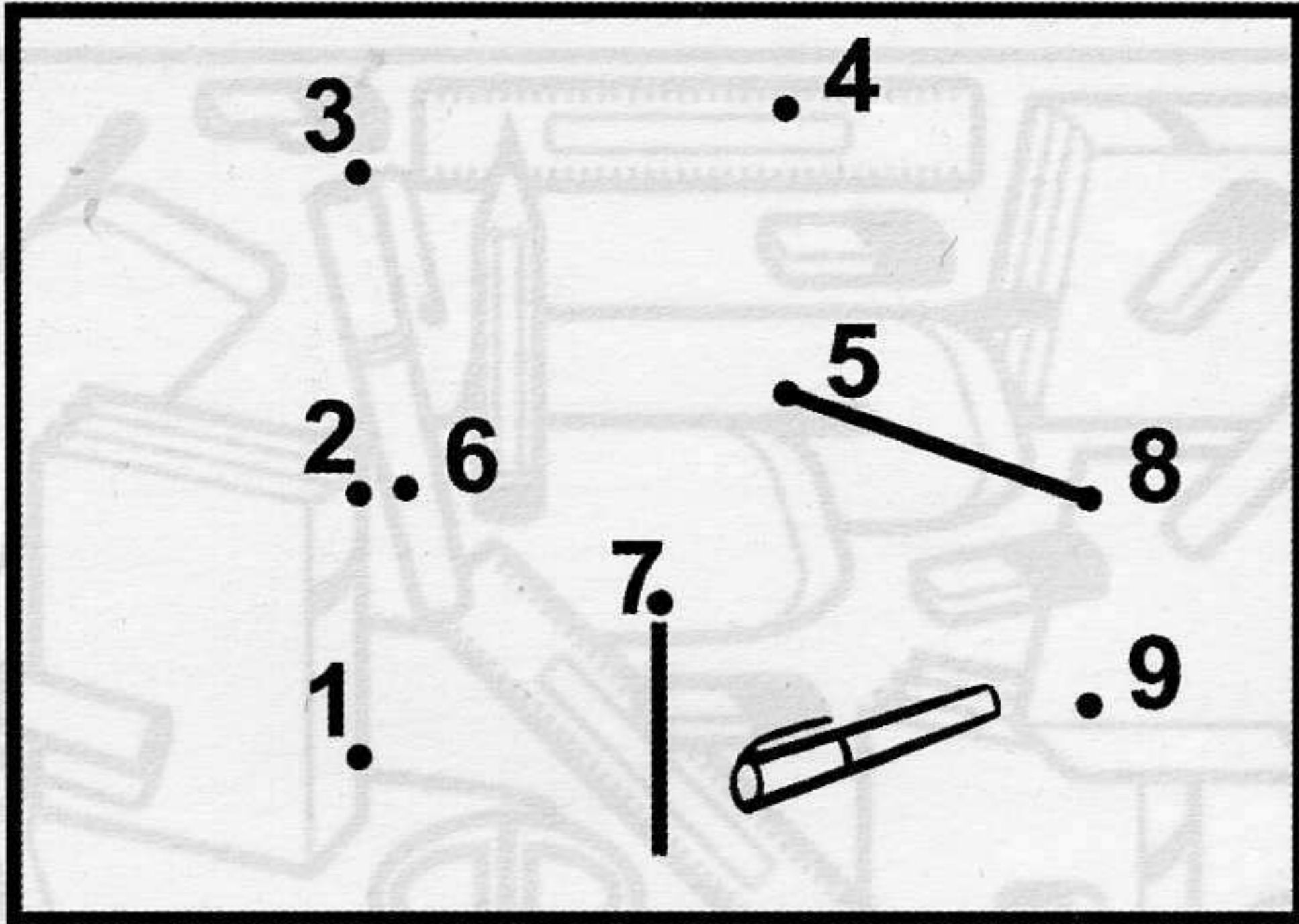

1 Where's the pen?

It's
 on
 under
 the chair.

2 Where's the ruler?

It's
 in
 on
 the school bag.

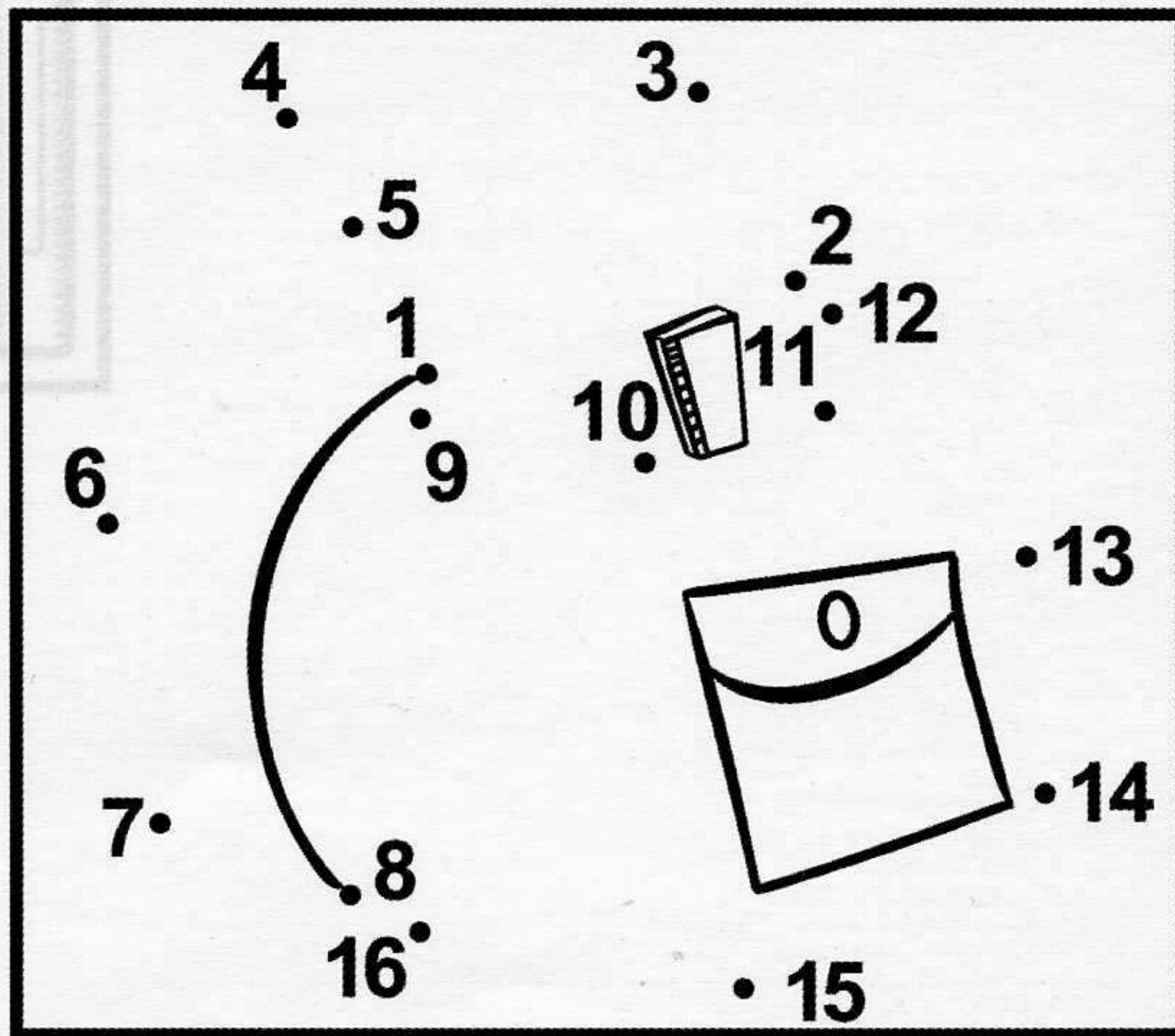

Unit 1 Activity 6

Look and write.

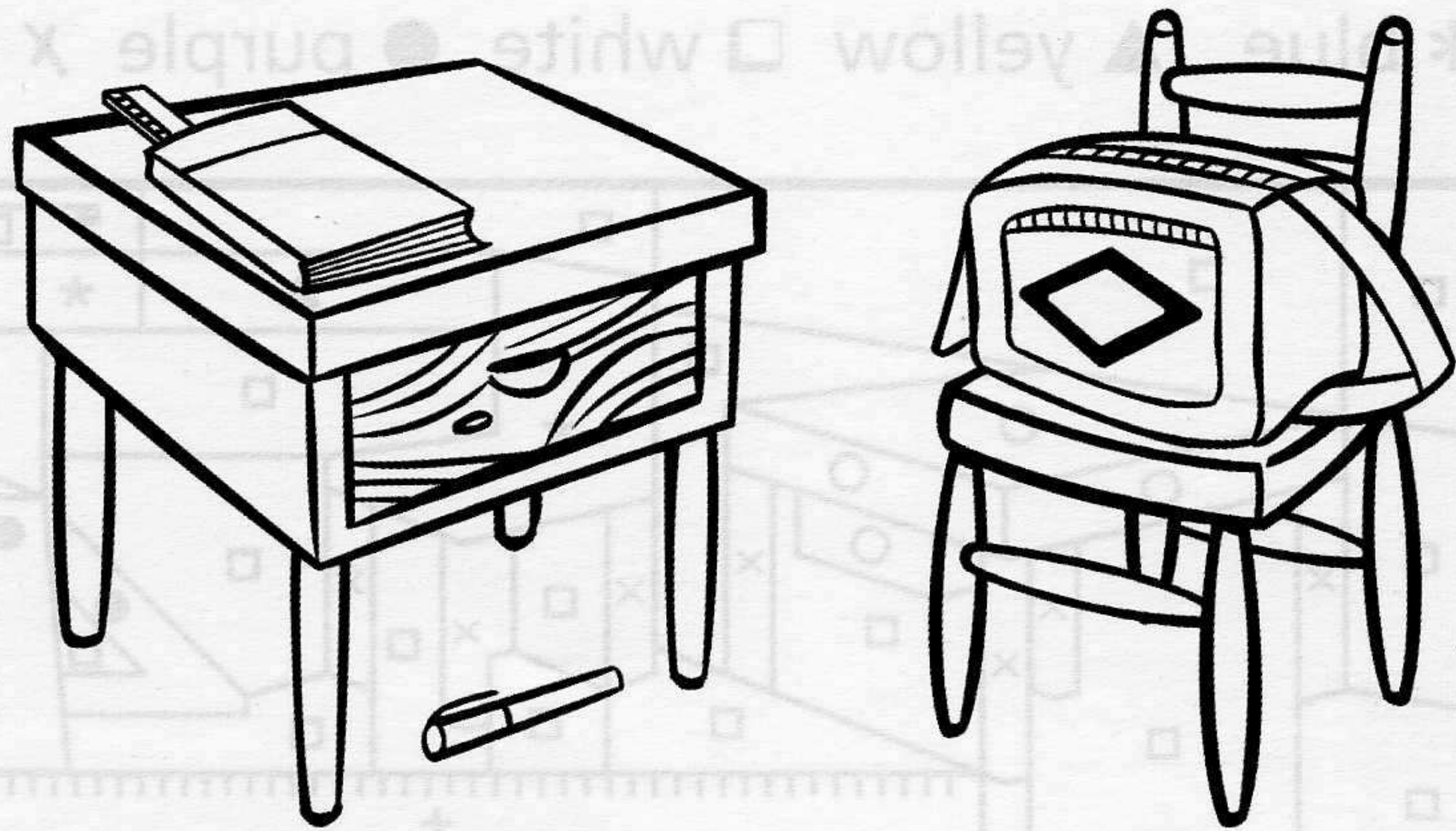

1 Where's the pen? It's under the desk

2 Where's the ruler? It's _____

3 Where's the school bag? It's _____

4 Where's the notebook? It's _____

Unit 1 Activity 3

Count, read and circle true (T) or false (F).

- | | | |
|----------------------|------------------------------------|---|
| 1 three pencils | <input checked="" type="radio"/> T | F |
| 2 five rulers | <input type="radio"/> T | F |
| 3 six pens | <input type="radio"/> T | F |
| 4 ten rubbers | <input type="radio"/> T | F |
| 5 eight pencil cases | <input type="radio"/> T | F |
| 6 two scissors | <input type="radio"/> T | F |
| 7 four notebooks | <input type="radio"/> T | F |

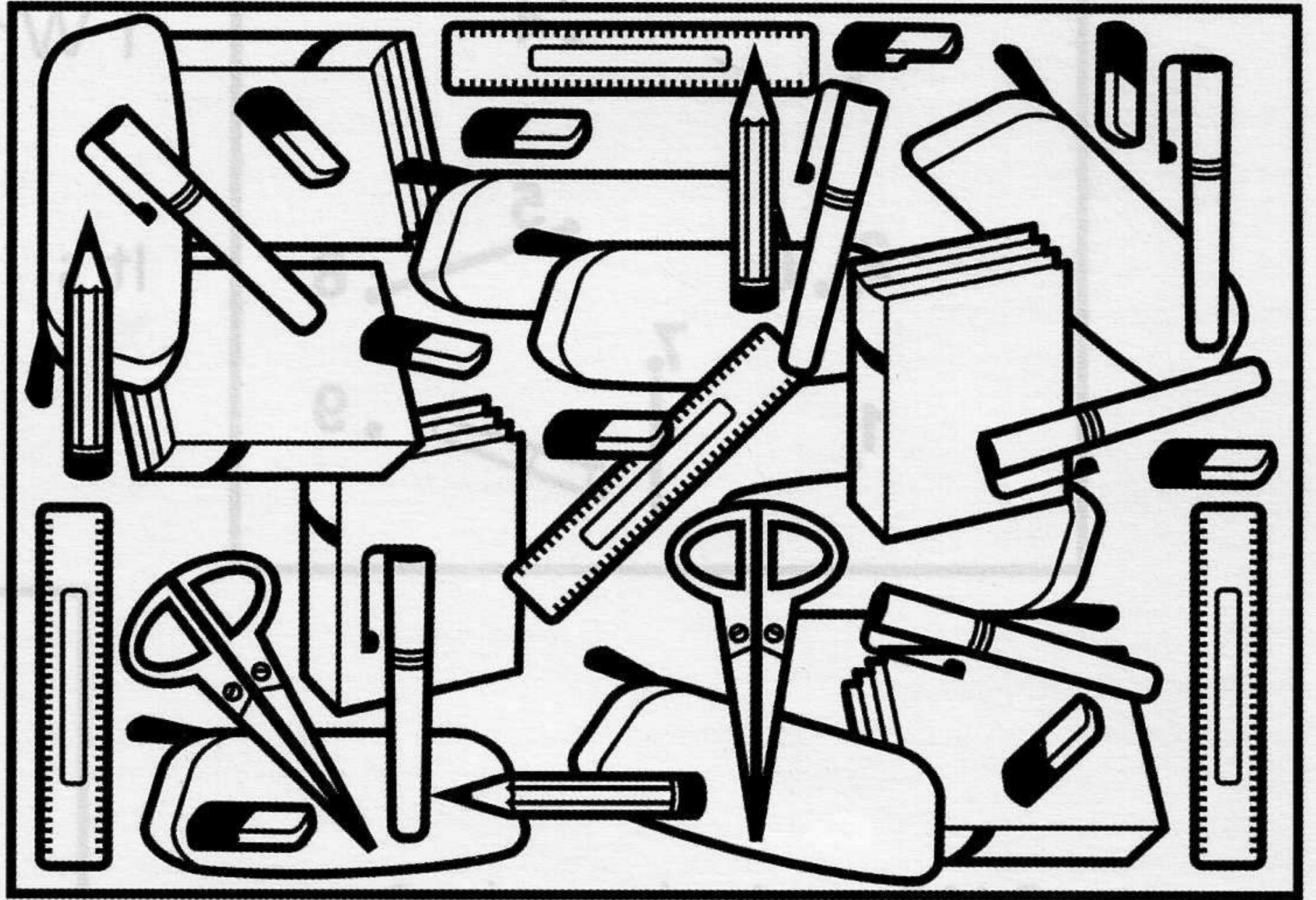

Unit 1 Activity 4

Colour, read and write.

* blue ▲ yellow □ white ● purple X green ○ black + red

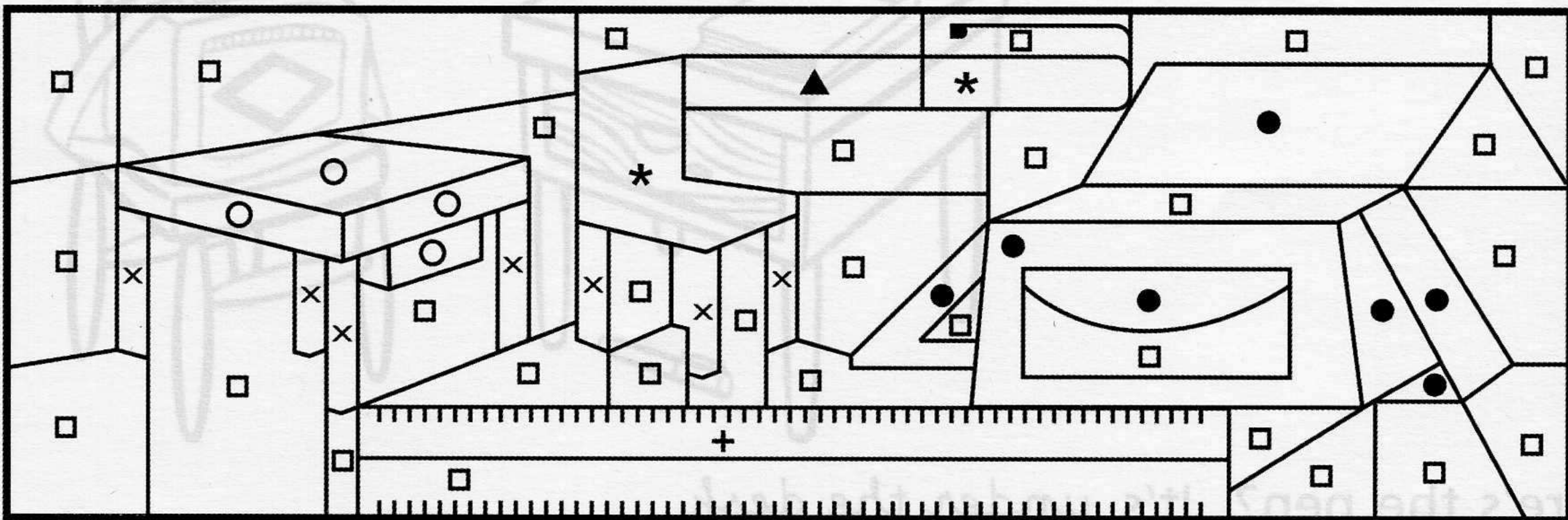

1 What is it? It's blue and yellow. It's a pen.

2 What is it? It's green and black. It's a _____

3 What is it? It's white and red. It's a _____

4 What is it? It's purple and white. It's a _____

5 What is it? It's blue and green. It's a _____

Unit 1 Activity 7

Colour, read and match.

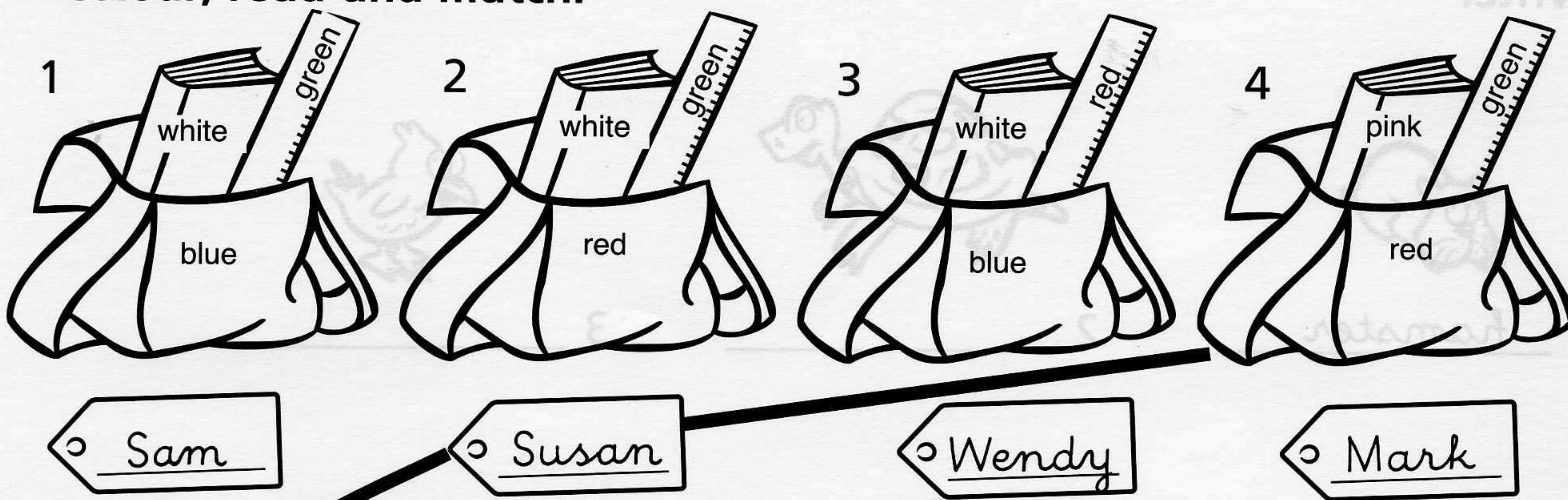

a I'm Susan. My school bag is red. My ruler is green and my book is pink.

b I'm Mark. My school bag is blue. My ruler is green and my book is white.

c I'm Sam. My school bag is red. My ruler is green and my book is white.

d I'm Wendy. My school bag is blue. My ruler is red and my book is white.

Unit 1 Activity 8

Look and write.

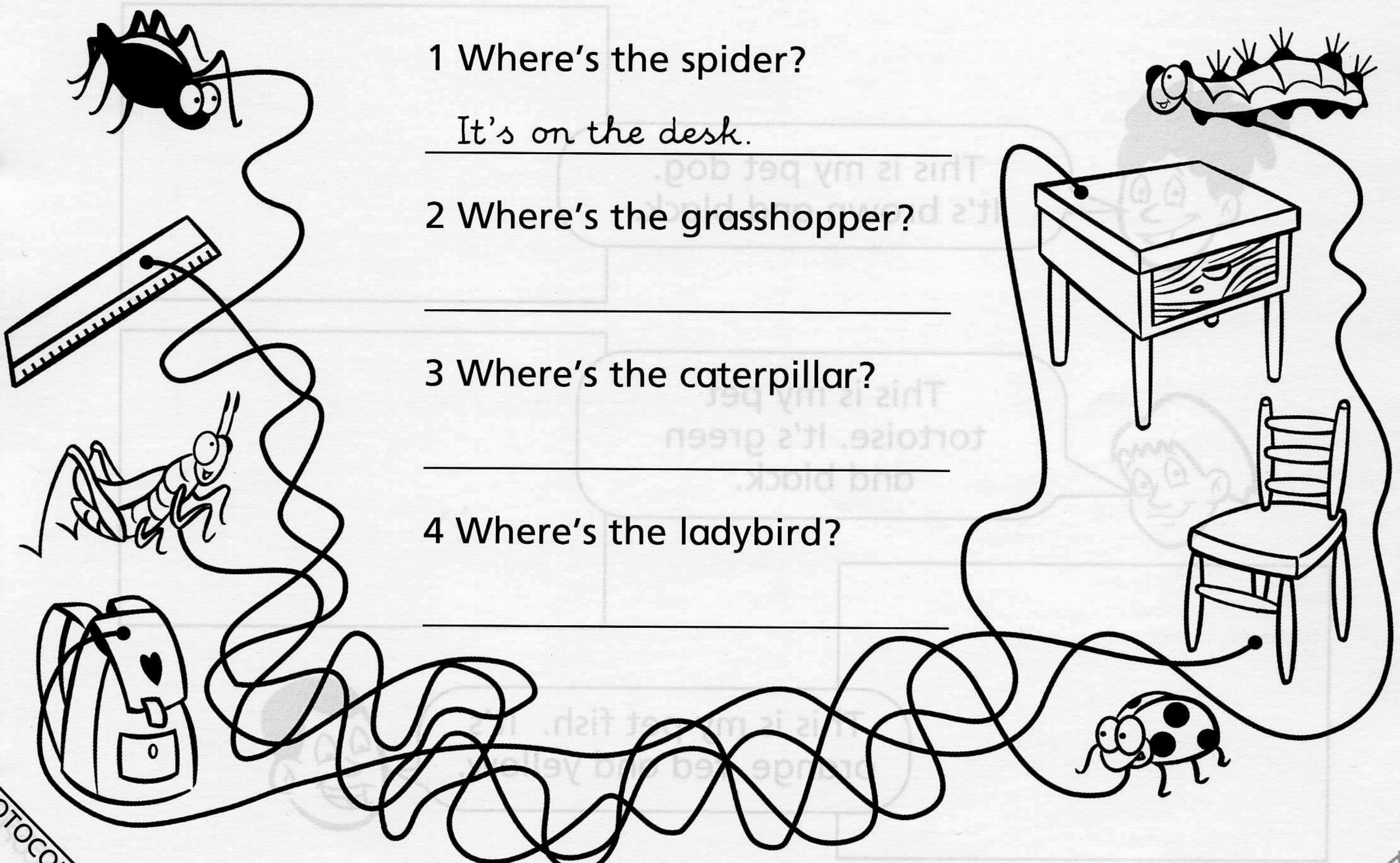

1 Where's the spider?

It's on the desk.

2 Where's the grasshopper?

3 Where's the caterpillar?

4 Where's the ladybird?

PHOTOCOPIABLE

Unit 1 Activity 9

Write.



1 hamster

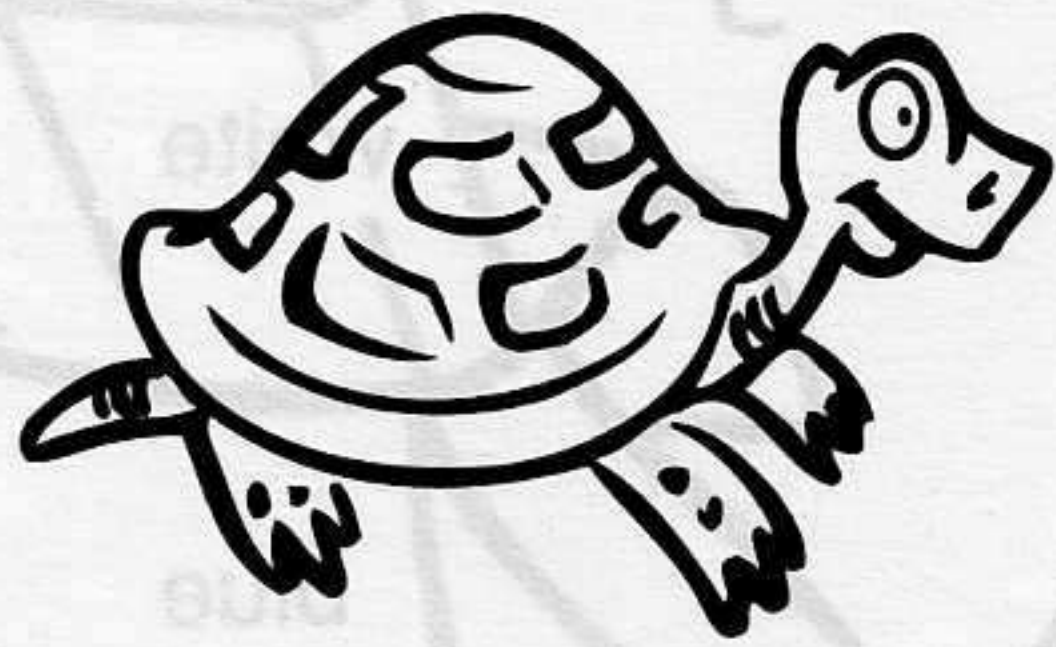

2 _____

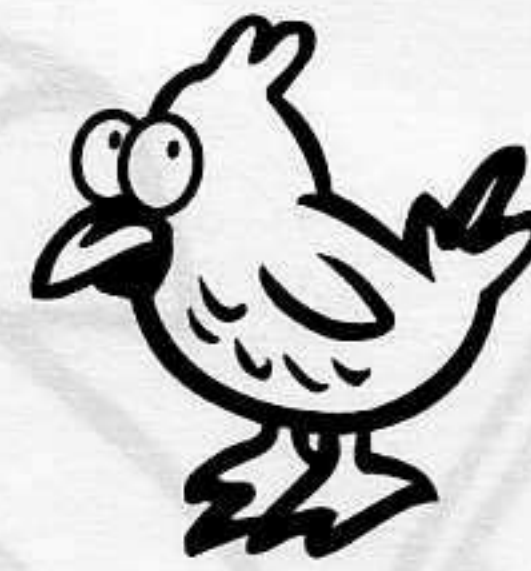

3 _____

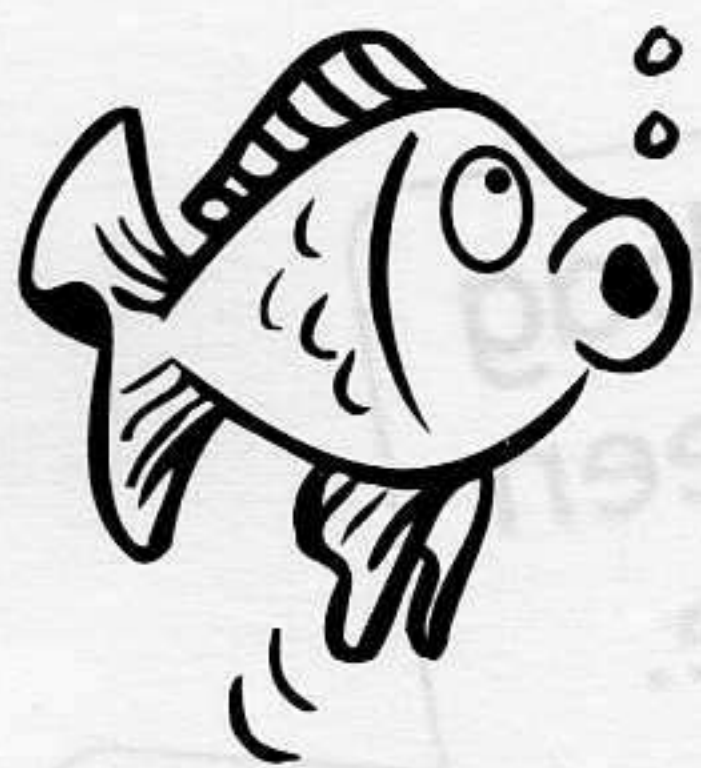

4 _____

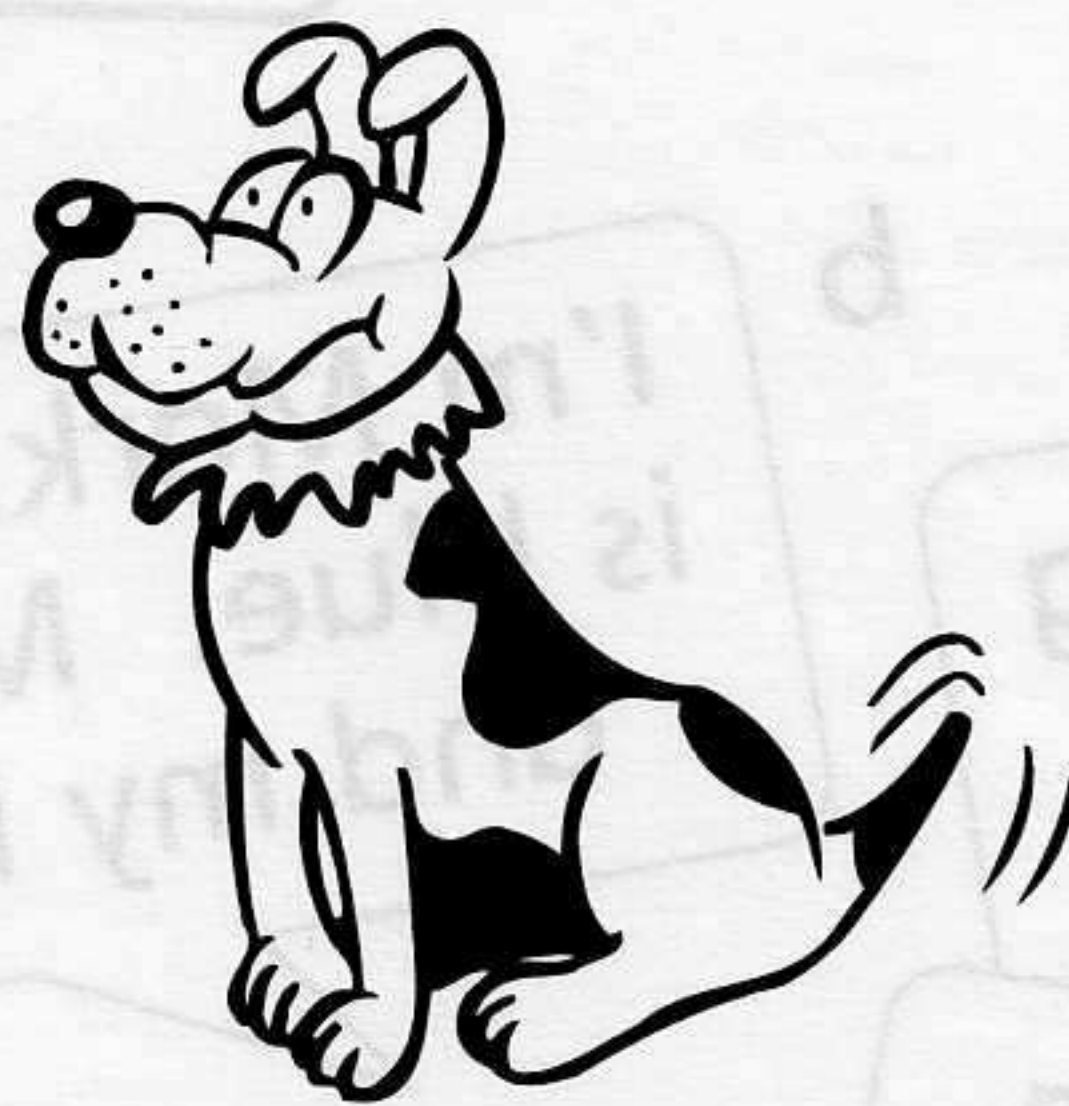

5 _____



6 _____

Unit 1 Activity 10

Read, draw and colour.



This is my pet dog.
It's brown and black.

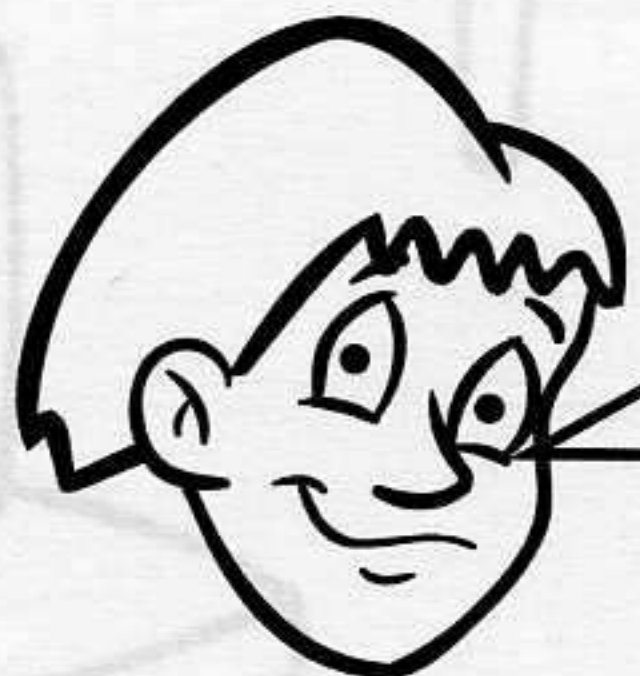
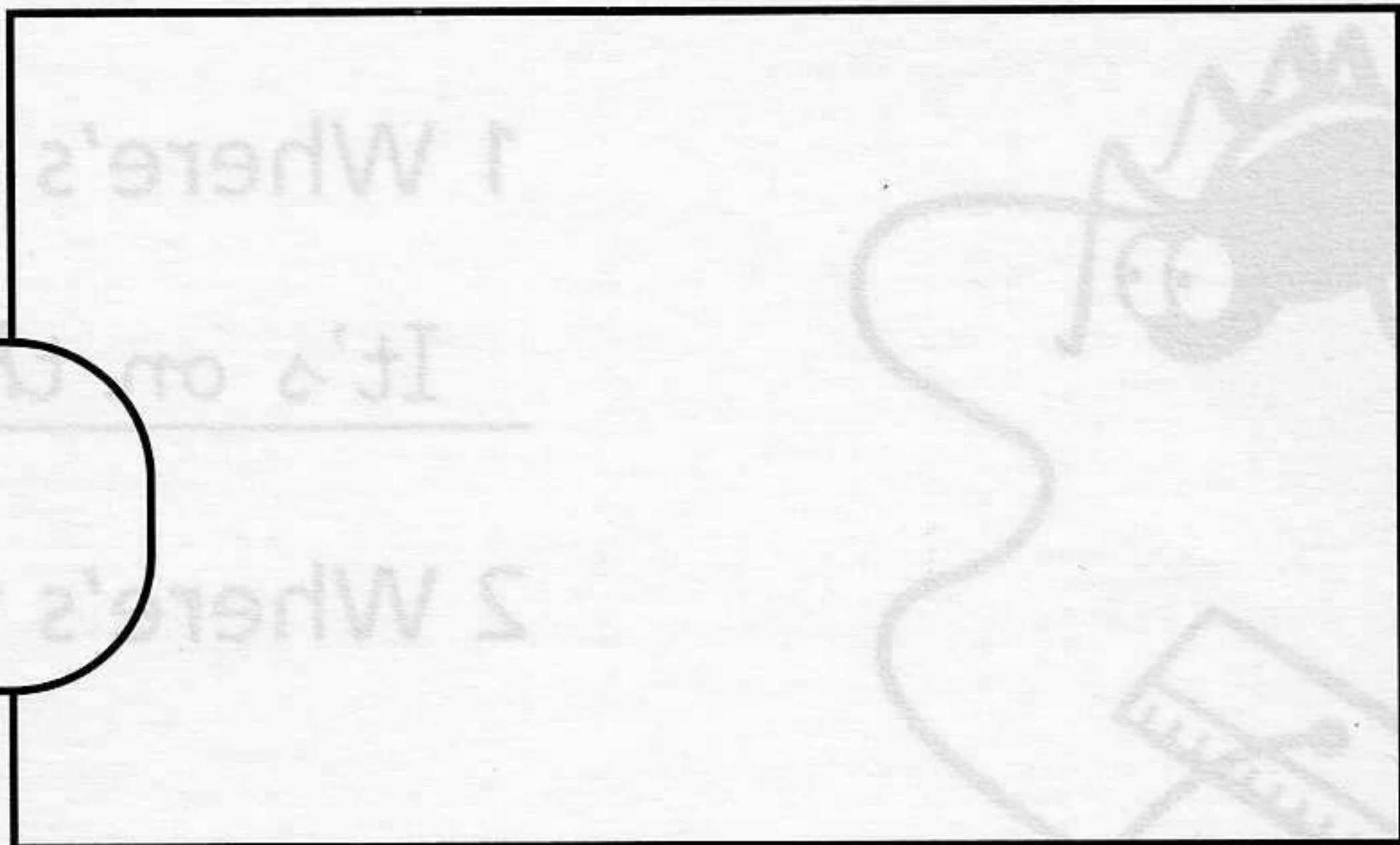

This is my pet
tortoise. It's green
and black.

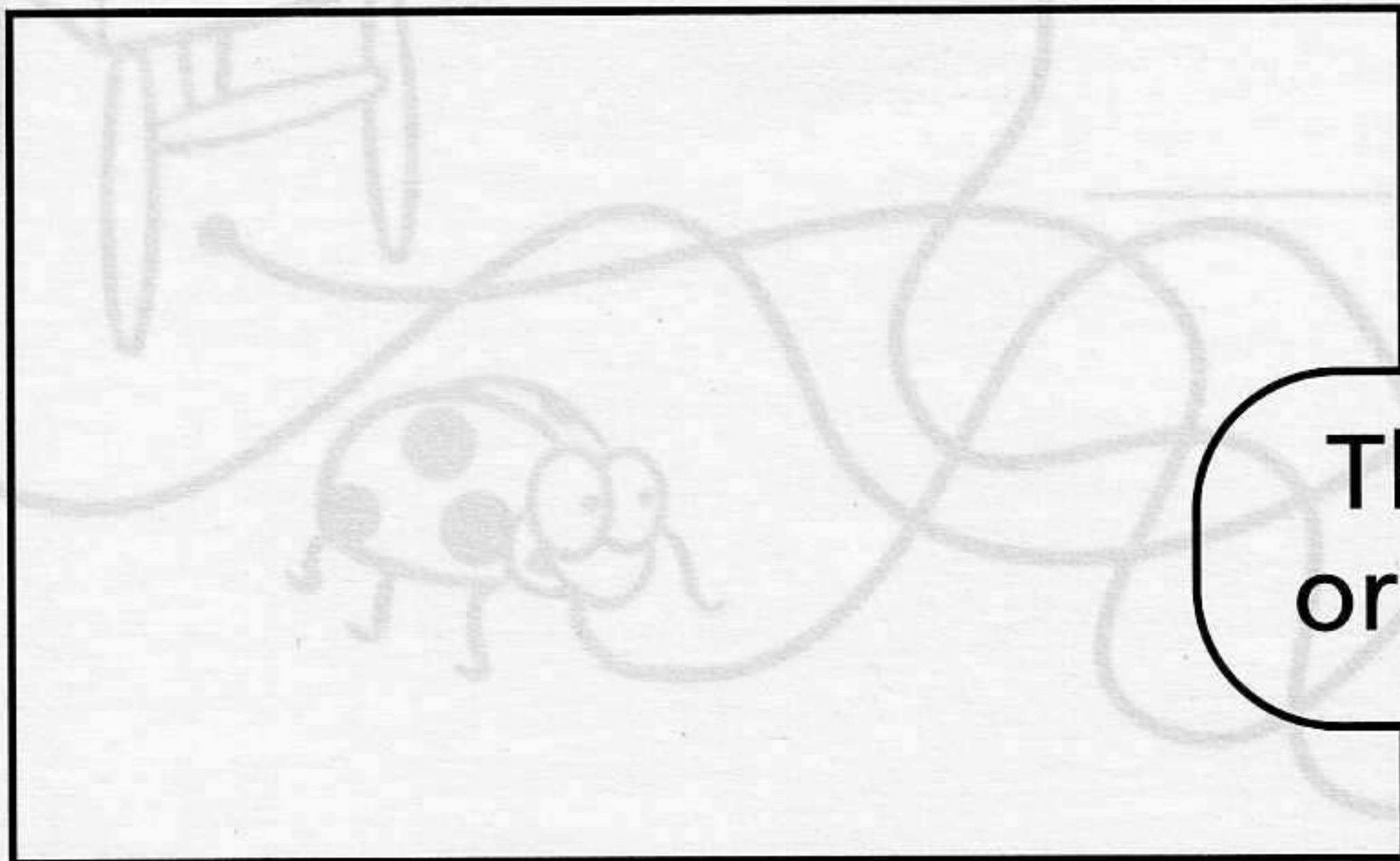
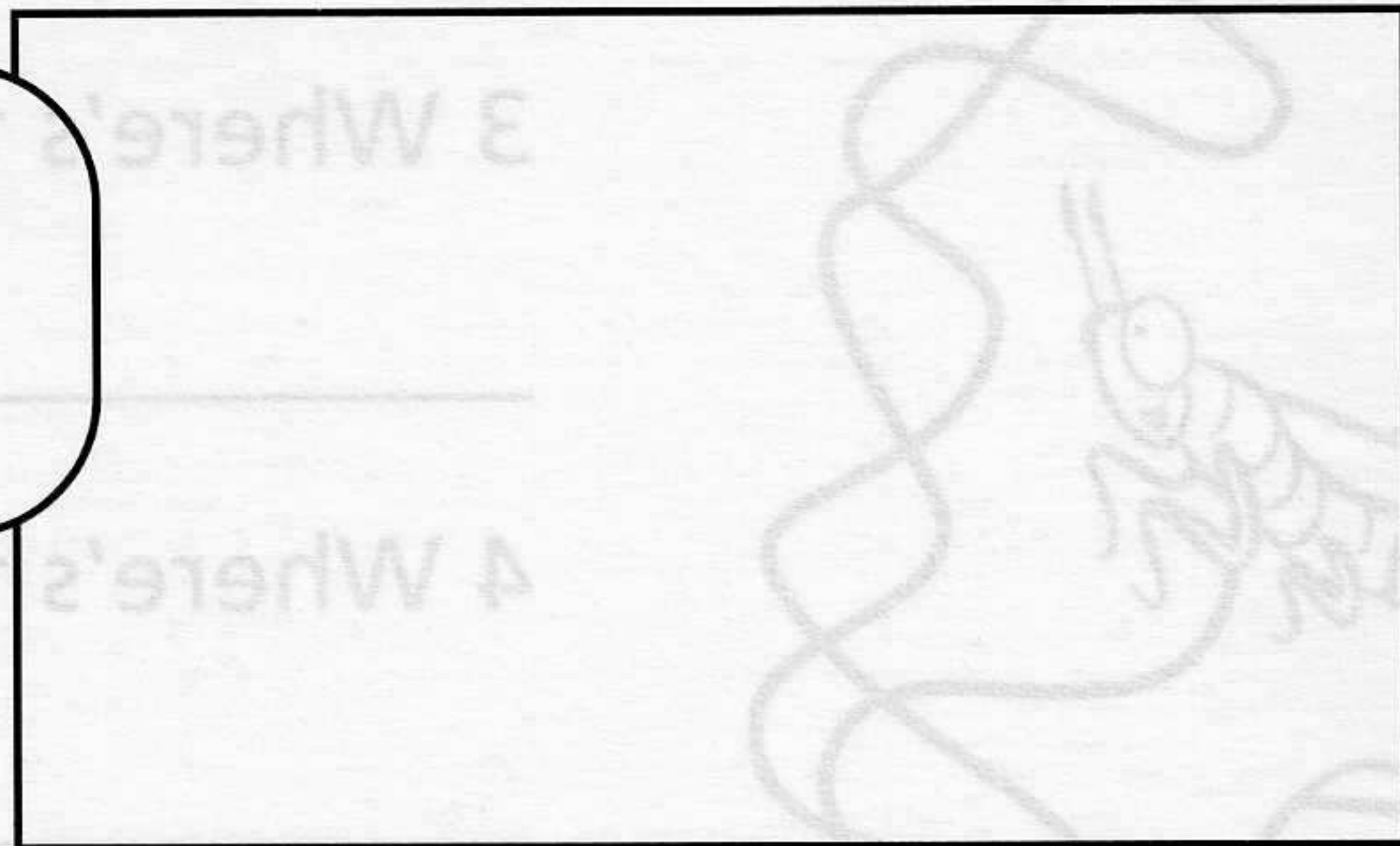

This is my pet fish. It's
orange, red and yellow.

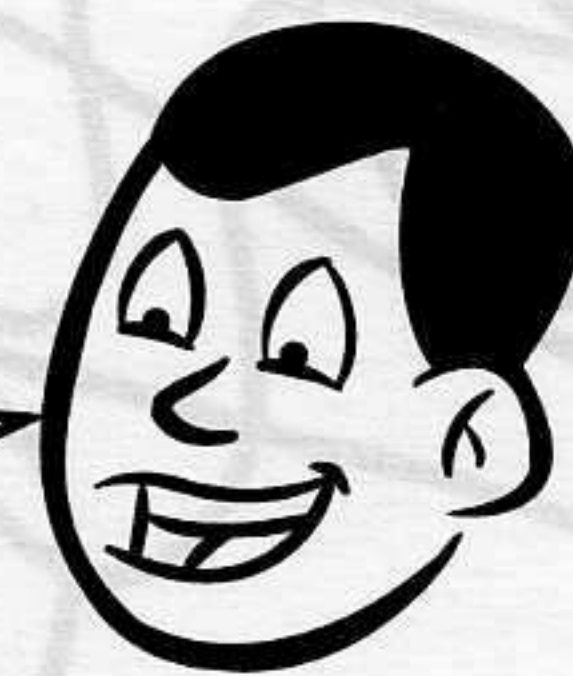

Unit 1 Activity 11

Read, look and circle true (T) or false (F).

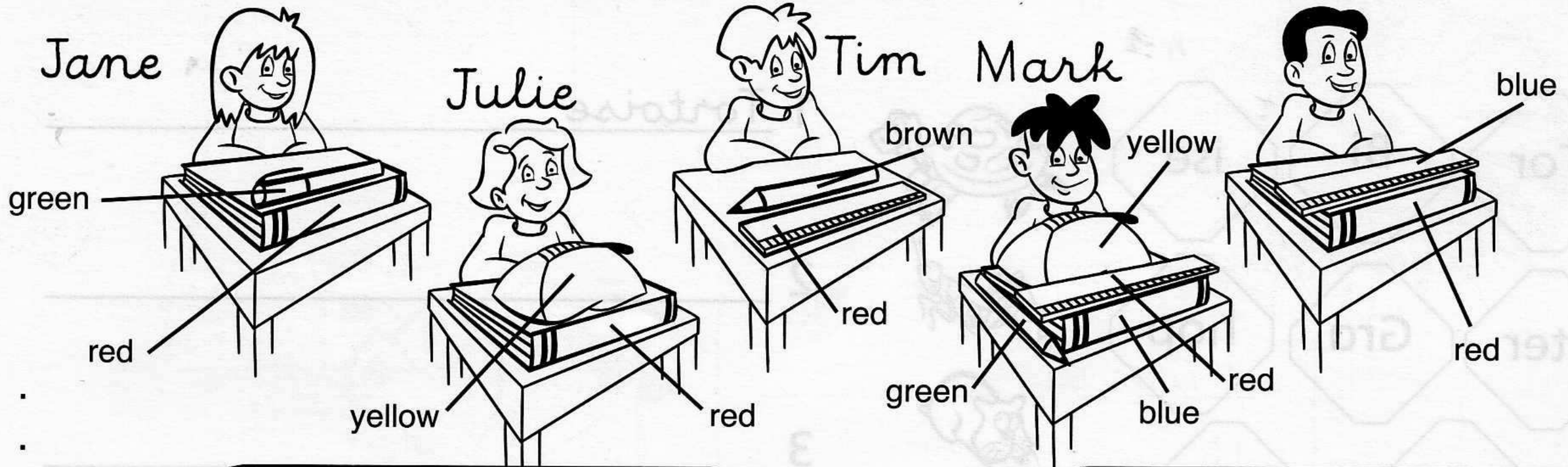

1 T
 F
 I'm Jane. My pen is green and my book is orange.

2 T
 F
 I'm Julie. My book is red and my pencil case is yellow.

3 T
 F
 I'm Tim. My pencil is brown and my ruler is blue.

4 T
 F
 I'm Mark. My pencil is green and my ruler is red. My book is blue and my pencil case is yellow.

5 T
 F
 I'm Paul. My book is red and my ruler is blue.

Unit 1 Activity 12

Look and write.

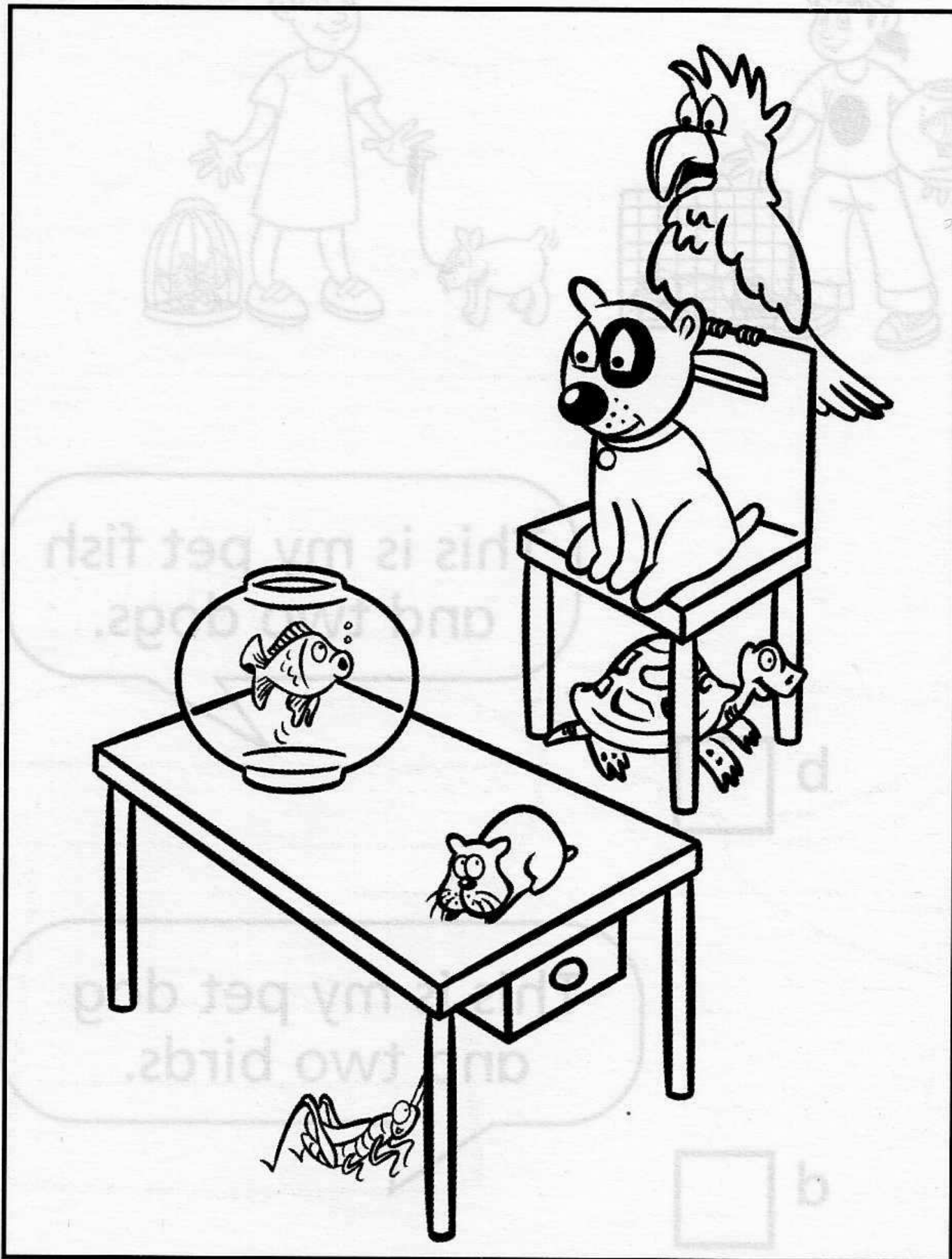

1 Where's the hamster?
 It's on the desk.

2 Where's the bird?

3 Where's the tortoise?





4 Where's the fish?

5 Where's the grasshopper?

6 Where's the dog?

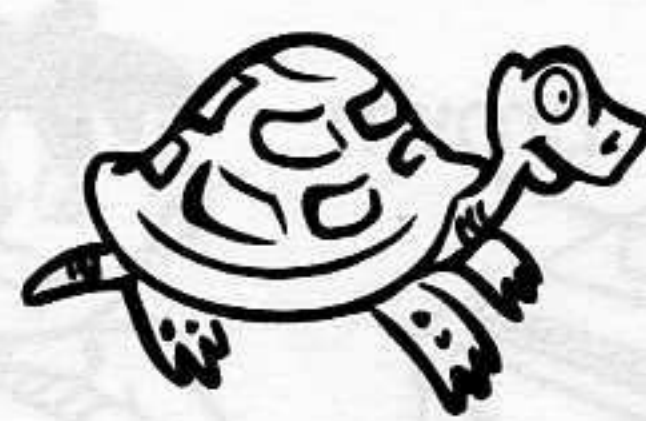
Unit 1 Activity 13

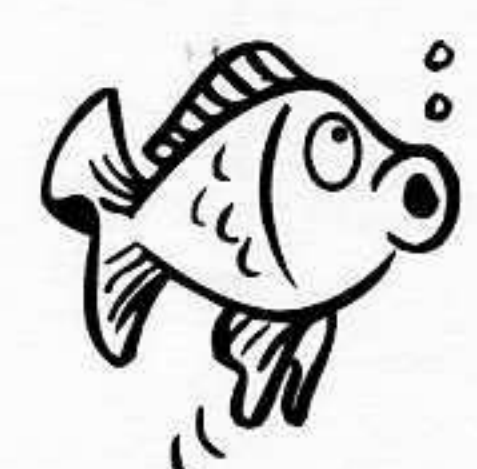

Colour the animal words. Write.

<table border="0"> <tr><td>Tor</td><td>Bi</td><td>ise</td></tr> <tr><td>ster</td><td>Gra</td><td>hop</td></tr> <tr><td>g</td><td>to</td></tr> <tr><td colspan="2">Ham</td></tr> <tr><td>sh</td><td>per</td></tr> <tr><td>rd</td><td>ss</td></tr> <tr><td>Do</td><td>Fi</td></tr> </table>	Tor	Bi	ise	ster	Gra	hop	g	to	Ham		sh	per	rd	ss	Do	Fi	     
Tor	Bi	ise															
ster	Gra	hop															
g	to																
Ham																	
sh	per																
rd	ss																
Do	Fi																

- 1 Tortoise
- 2 _____
- 3 _____
- 4 _____
- 5 _____
- 6 _____

Unit 1 Activity 14

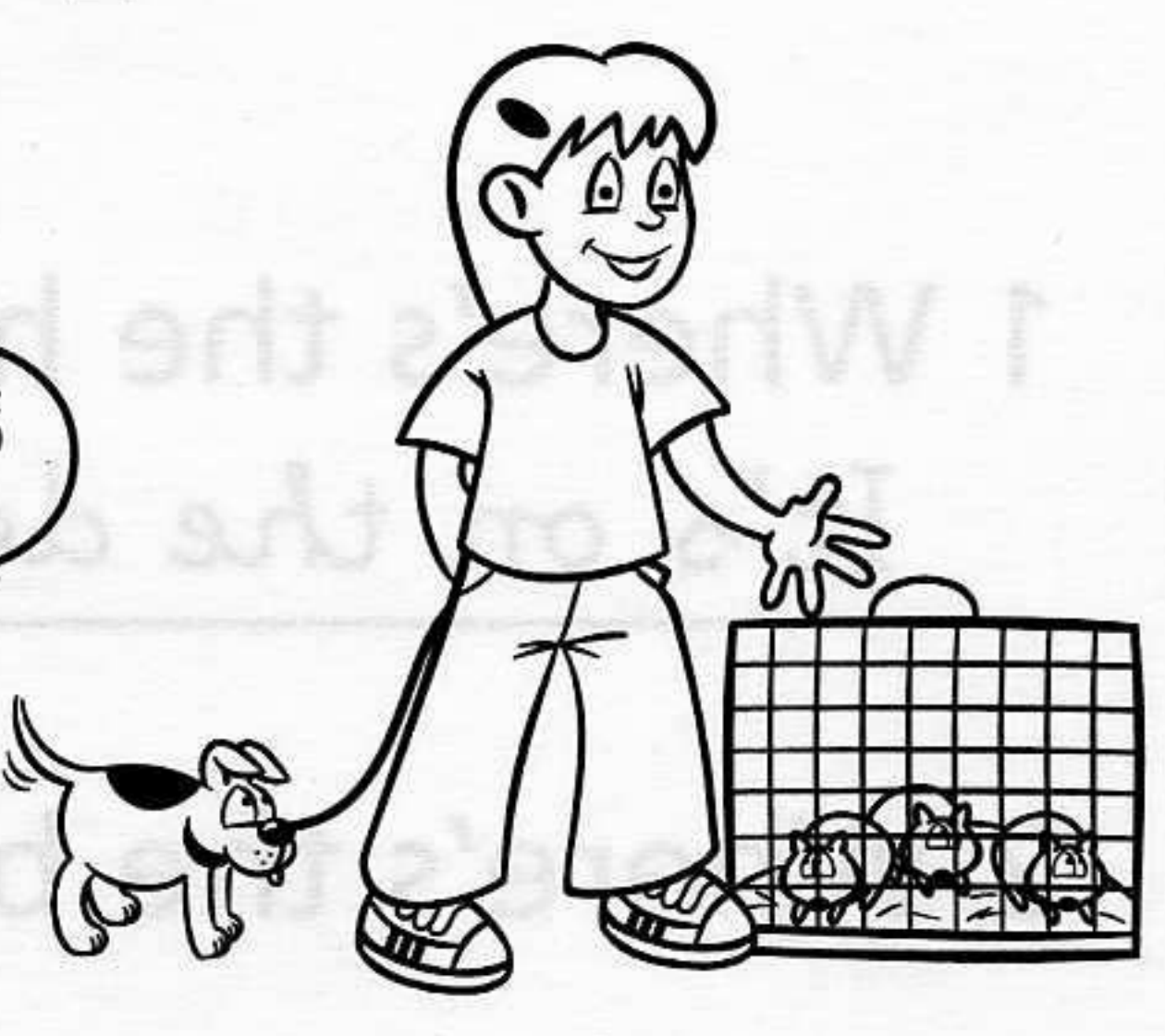
Read, look and number.

1	2	3	4
			

a 2 2 This is my pet dog and three hamsters.

b This is my pet fish and two dogs.

c This is my pet fish and two hamsters.

d This is my pet dog and two birds.

Unit 2 Activity 3

Write.

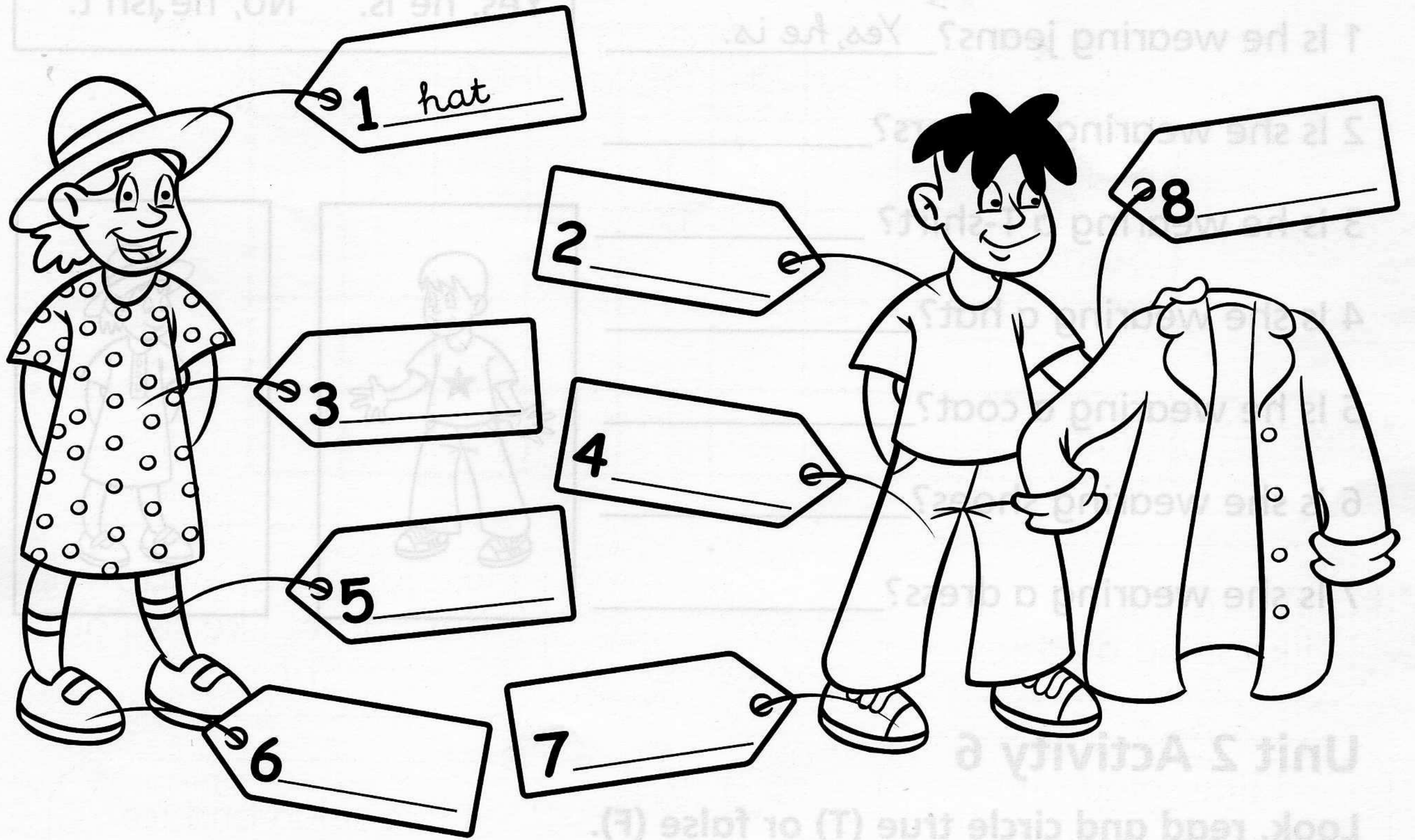

Unit 2 Activity 4

Read and match.

a 1 He's wearing a T-shirt and jeans.

b 2 She's wearing jeans, a T-shirt and a hat.

c 3 She's wearing a dress and shoes.

d 4 He's wearing jeans, a coat and trainers.

e 5 He's wearing a dress, a hat and shoes.

f 6 She's wearing a coat and shoes.

Unit 2 Activity 9

Circle seven family words. Write.

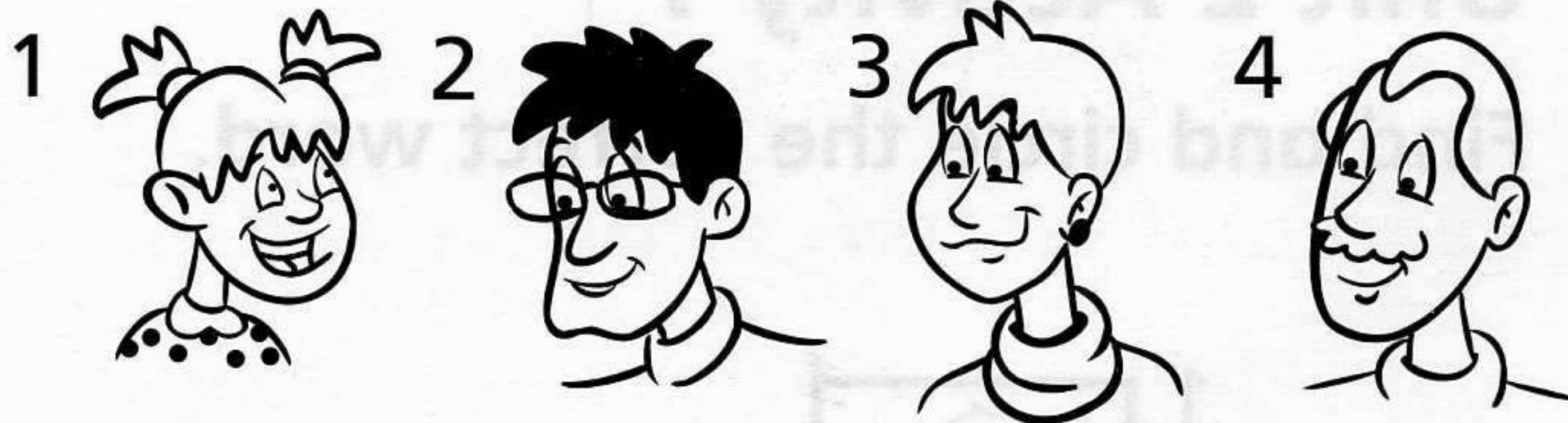

1 c _____ 2 d _____

3 m _____ 4 u _____

5 a _____ 6 s _____

7 b _____

g	e	g	e	d	j	s	s	e	m
d	b	h	t	f	k	u	h	l	u
b	s	r	h	b	o	s	k	i	m
a	l	c	o	u	s	i	n	g	d
c	d	s	k	t	l	s	l	s	g
k	o	a	l	j	h	t	d	a	d
o	t	u	n	c	l	e	e	u	o
l	r	c	s	s	d	r	r	n	a
m	e	k	a	b	a	w	c	t	e
p	r	s	b	c	d	a	e	f	g



Unit 2 Activity 10

Look and write (✓).

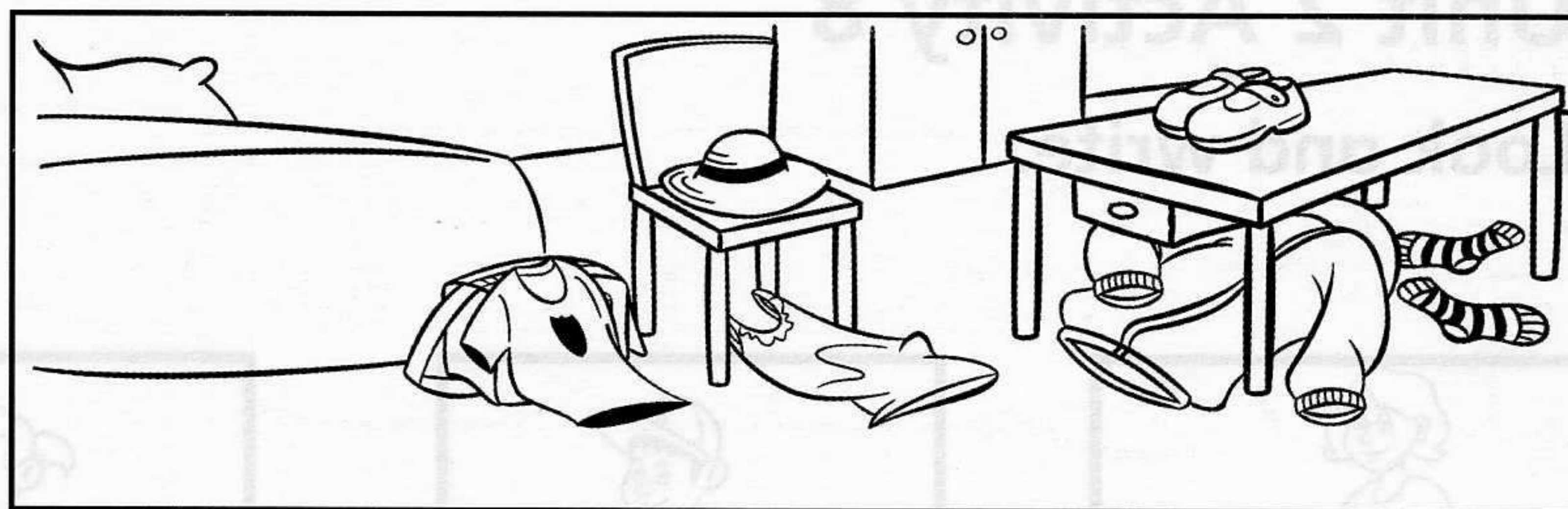

- | | | |
|------------------------|-------------------------|-------------------------------------|
| 1 Where's the dress? | It's on the chair. | <input type="checkbox"/> |
| | It's under the chair. | <input checked="" type="checkbox"/> |
| 2 Where are the shoes? | They're on the desk. | <input type="checkbox"/> |
| | They're under the desk. | <input type="checkbox"/> |
| 3 Where's the T-shirt? | It's in the school bag. | <input type="checkbox"/> |
| | It's on the school bag. | <input type="checkbox"/> |
| 4 Where's the coat? | It's on the desk. | <input type="checkbox"/> |
| | It's under the desk. | <input type="checkbox"/> |
| 5 Where's the hat? | It's on the chair. | <input type="checkbox"/> |
| | It's under the chair. | <input type="checkbox"/> |
| 6 Where are the socks? | They're under the desk. | <input type="checkbox"/> |
| | They're on the desk. | <input type="checkbox"/> |

Unit 2 Activity 13

Look, read and write.

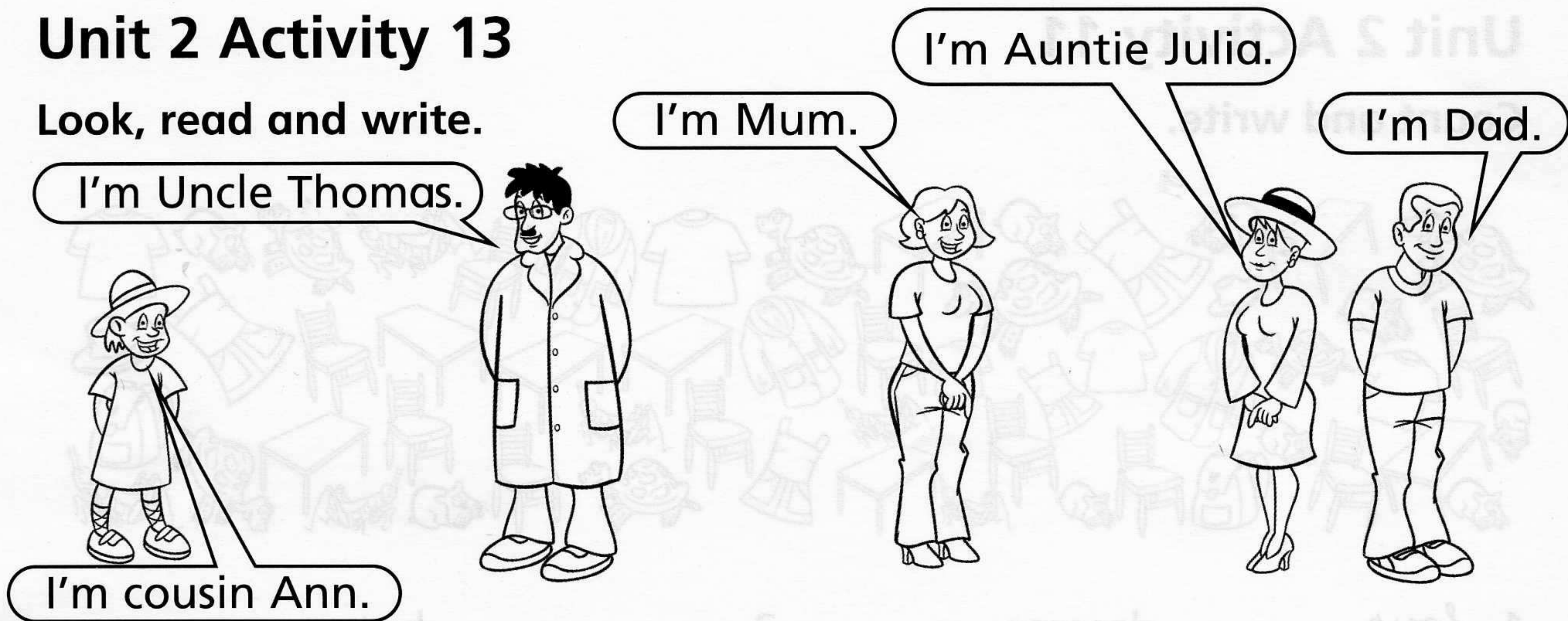

- 1 She's wearing jeans, a T-shirt and shoes. She's Mum.
- 2 He's wearing jeans, a T-shirt and trainers. He's _____
- 3 She's wearing a dress, a hat and trainers. She's _____
- 4 He's wearing jeans, a coat and shoes. He's _____
- 5 She's wearing a dress, shoes and a hat. She's _____

Unit 2 Activity 14

Read and write.

T-shirt ~~mum~~ ~~tortoise~~ ~~coat~~ ~~notebook~~ hamster socks bird
 pen auntie grasshopper school bag hat brother sister dog
 uncle dress chair jeans shoes dad cousin fish ruler
 trainers desk

1 Clothes



2 Family

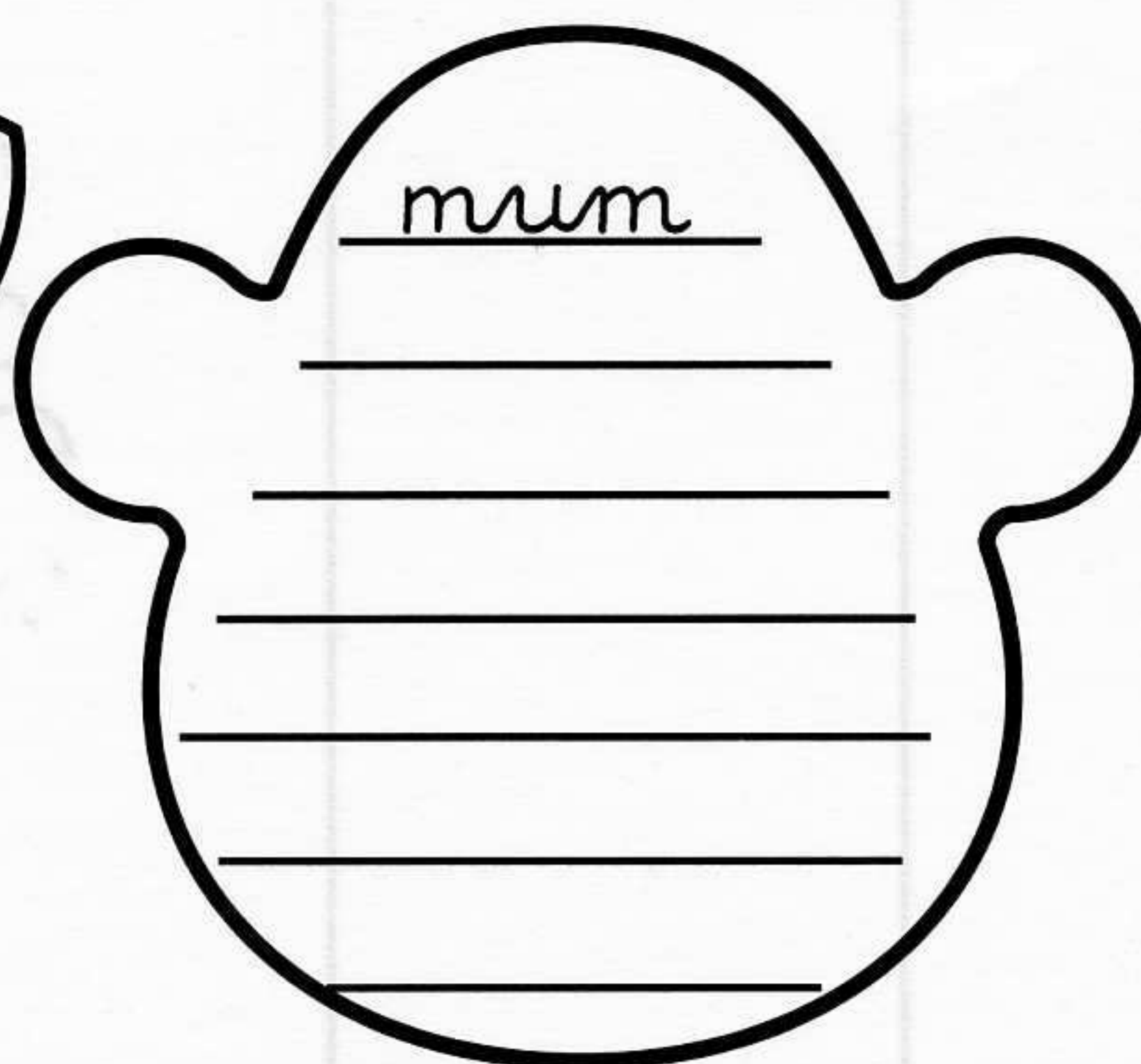

3 Classroom

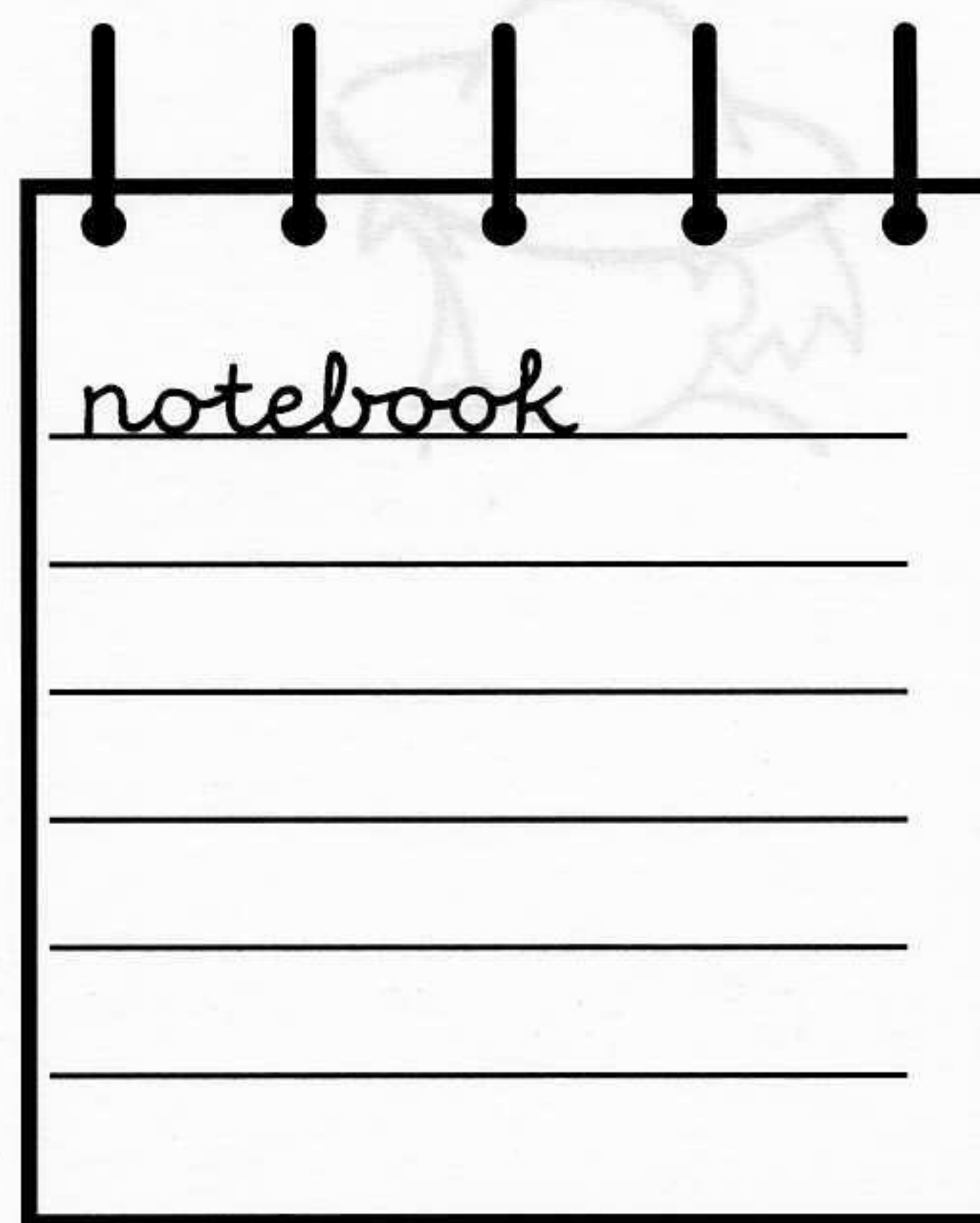

4 Animals

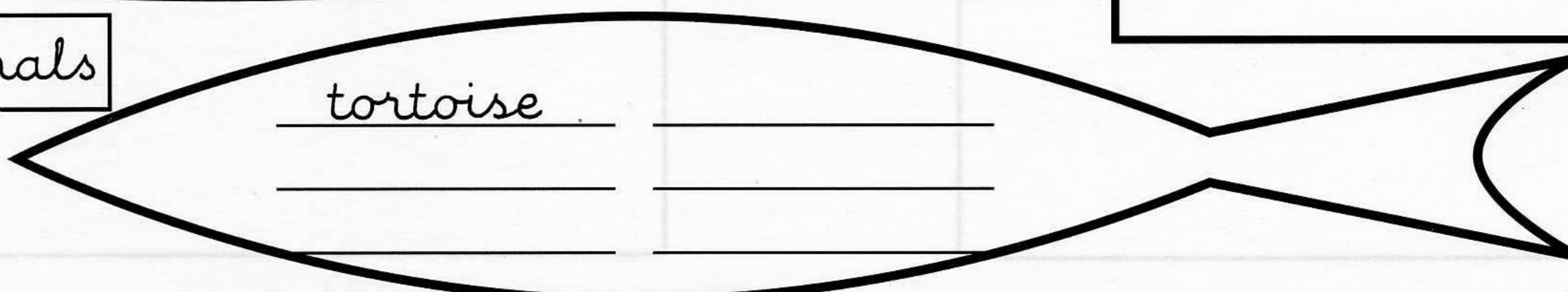

Unit 2 Activity 15

Read and colour.

This is a photo of my mum, my dad, my uncle, my auntie and my cousin. My mum's wearing a red and blue dress and black shoes. My dad's wearing a blue T-shirt, blue jeans and white trainers. My auntie's wearing a red T-shirt, black jeans and blue shoes. My uncle's wearing a brown coat, blue jeans and brown shoes. My cousin's wearing a purple and pink dress, yellow socks, blue shoes and a green hat.

Emily

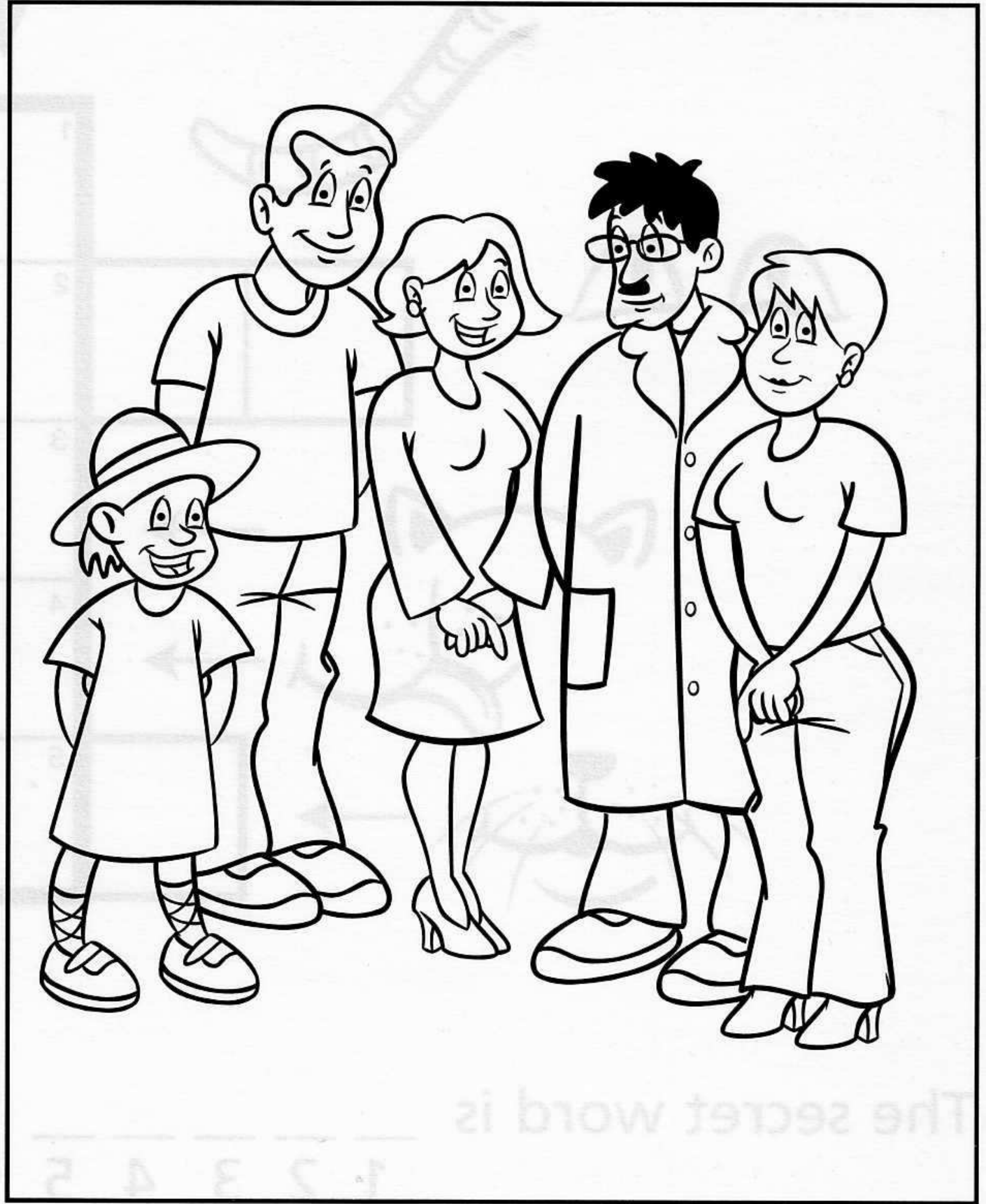

Unit 2 Activity 16

Look and write.

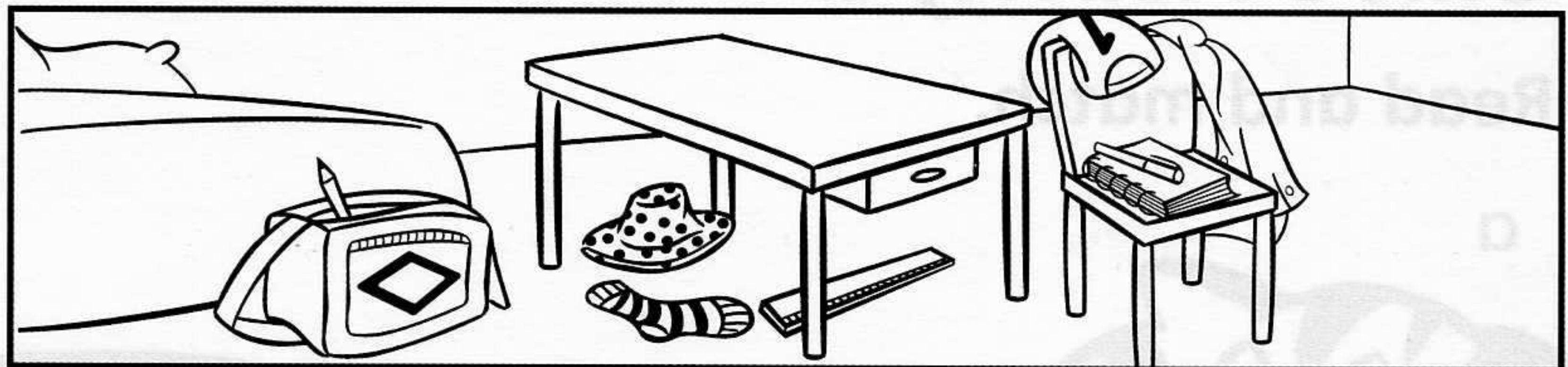

- 1 Where's the sock? It's under the desk.
- 2 Where's the pen? _____
- 3 Where's the pencil? _____
- 4 Where's the T-shirt? _____
- 5 Where's the hat? _____
- 6 Where's the notebook? _____
- 7 Where's the ruler? _____
- 8 Where's the coat? _____

Unit 3 Activity 1

Write. Find the secret word.

The secret word is
 1 2 3 4 5

Unit 3 Activity 2

Read and match.

a 1 I've got eight legs and two eyes.

b 2 I've got whiskers, two eyes, two ears and a tail.

c 3 I've got two legs and two eyes.

d 4 I haven't got legs. I've got a long tongue.

Unit 3 Activity 3

Write animal words.

NO LEGS



TWO LEGS



FOUR LEGS
tiger

EIGHT LEGS

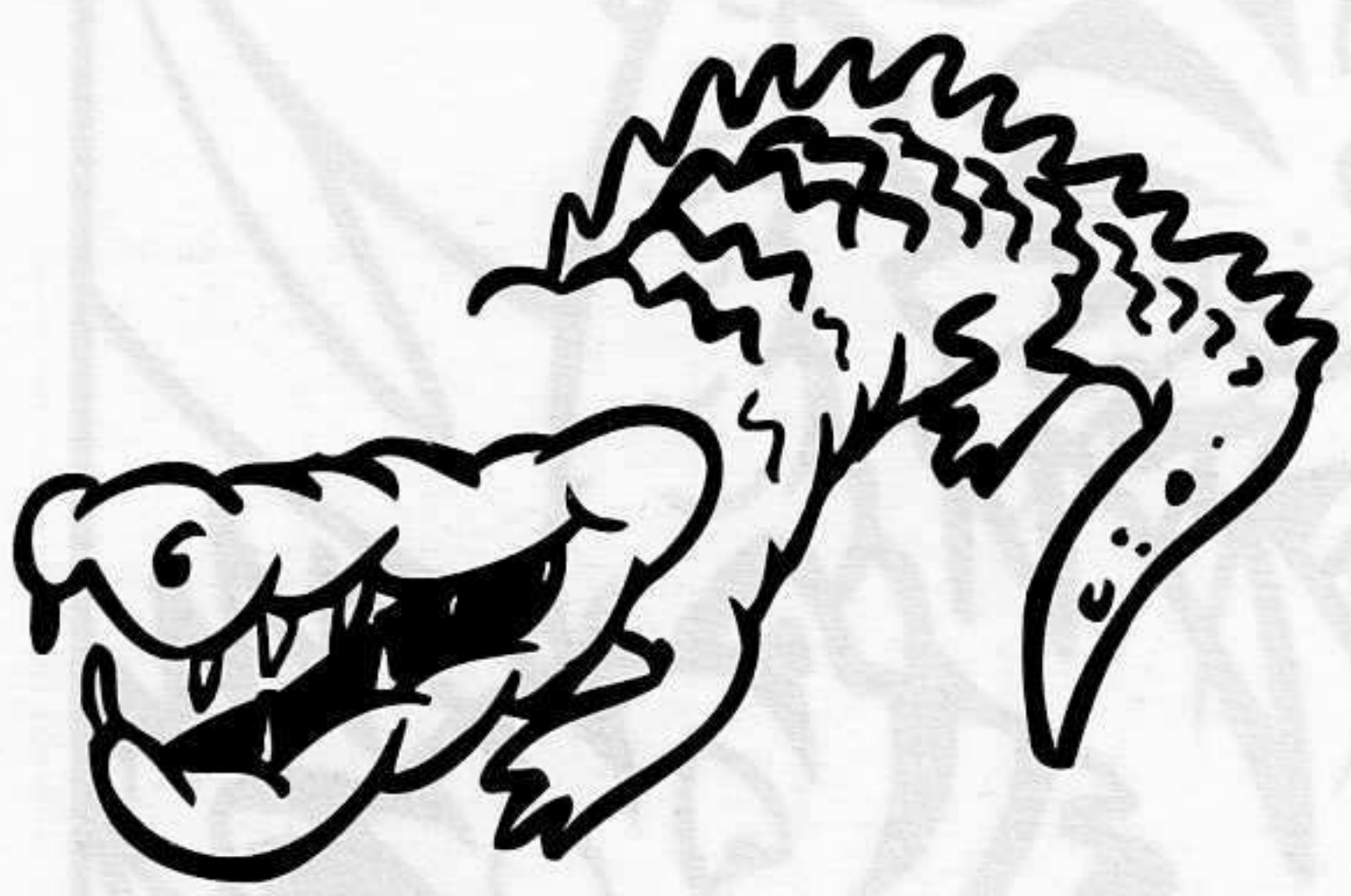
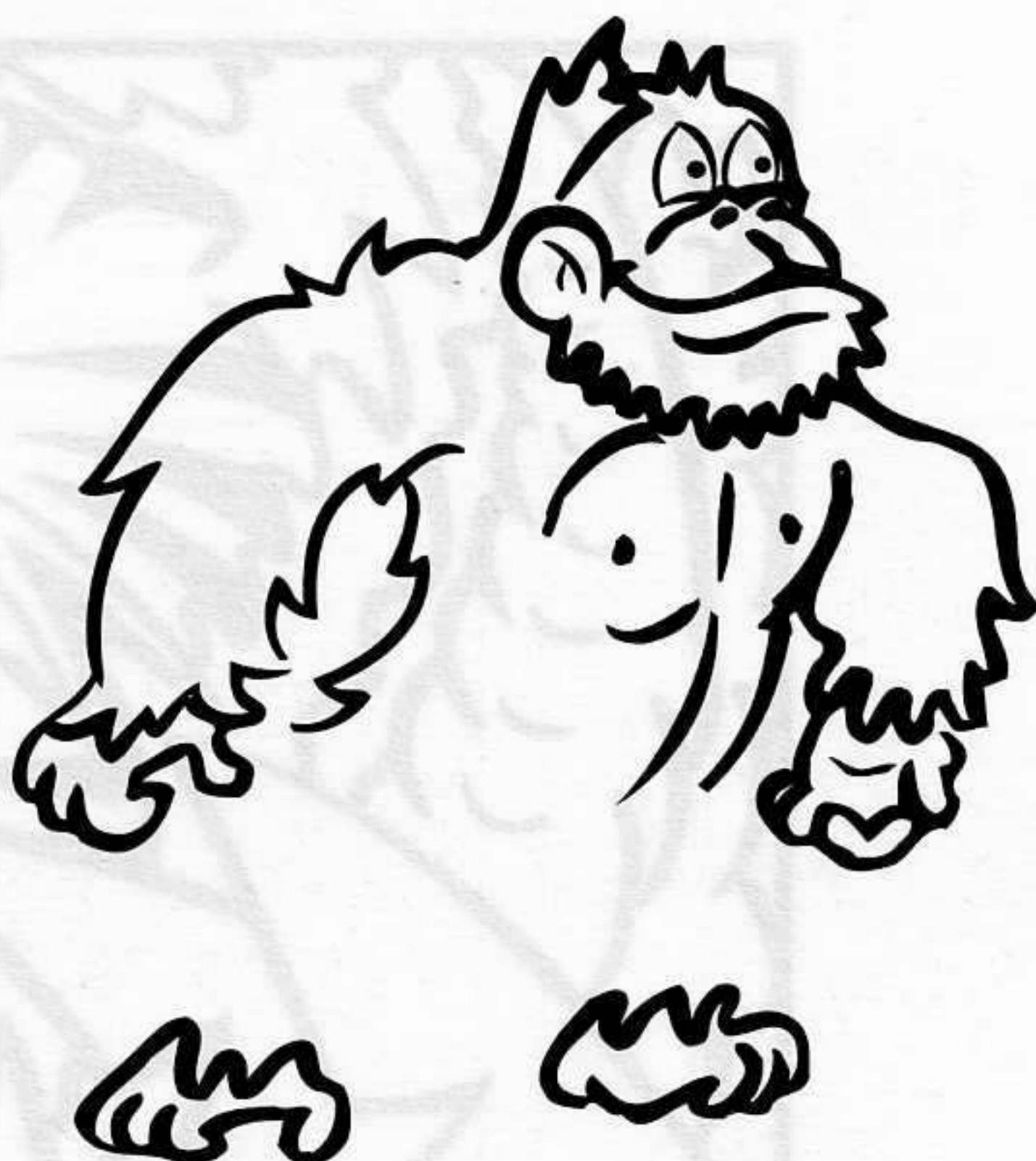
Unit 3 Activity 4

Draw and write.

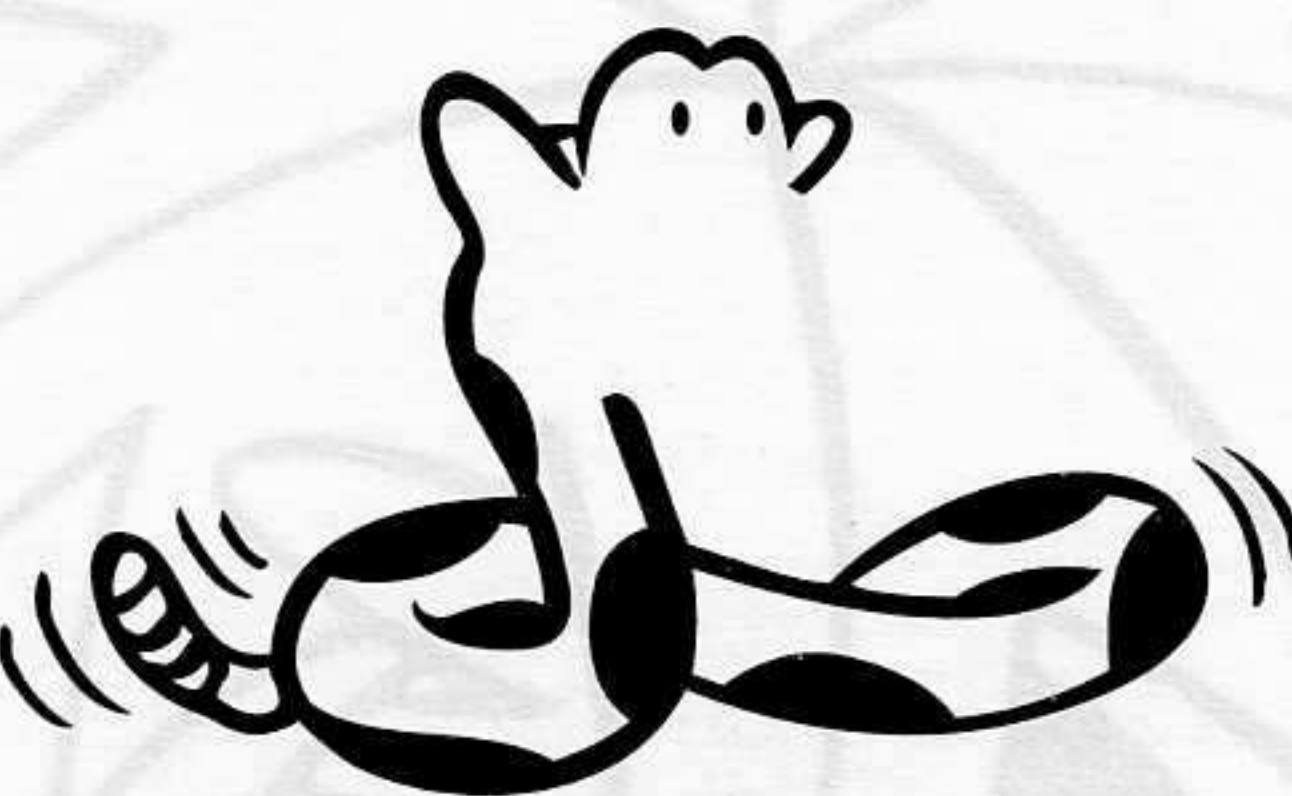
 1 I haven't got eyes. 2  3 

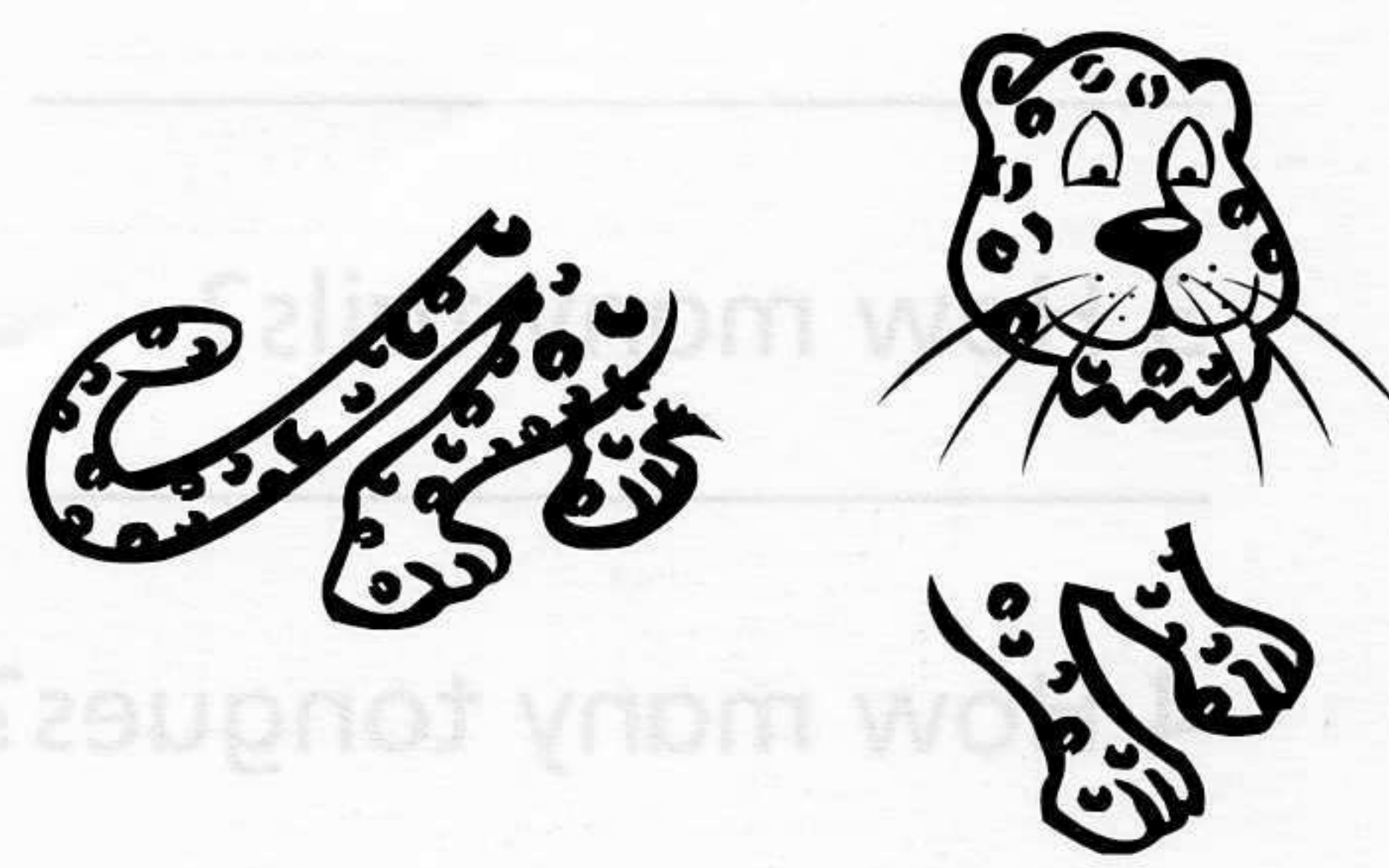
4  5  6 

PHOTOCOPIABLE

Unit 3 Activity 5

Read and colour.



- Colour the animals with whiskers blue.
- Colour the animal with a very long tail yellow.
- Colour the animal with two legs brown.
- Colour the animal with a long tongue green.
- Colour the animal with eight legs black.

Unit 3 Activity 6

Count and write.

1 How many eyes?

four

2 How many whiskers?

3 How many tails?

4 How many tongues?



Unit 3 Activity 7

Order and write. Circle true (T) or false (F).

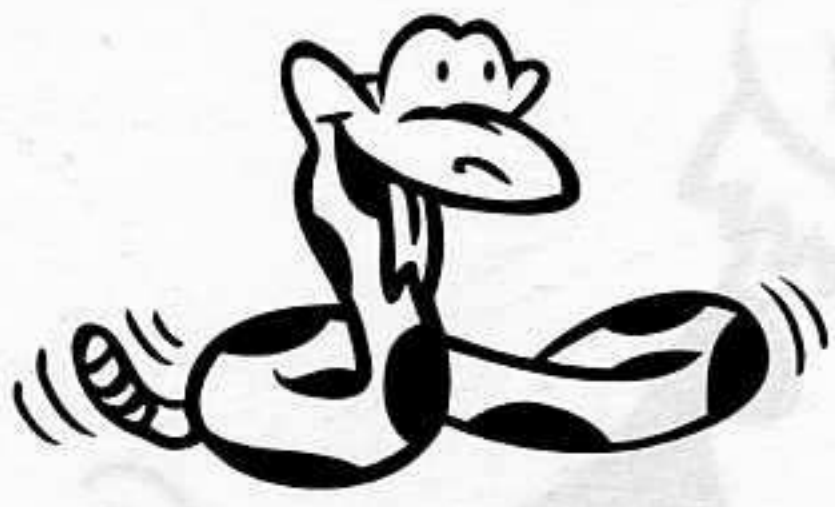

a I tongue 've long got

1 I've got a long tongue.

T / F



big 've body I got a

2 _____

T / F



whiskers eyes I got 've and two

3 _____

T / F

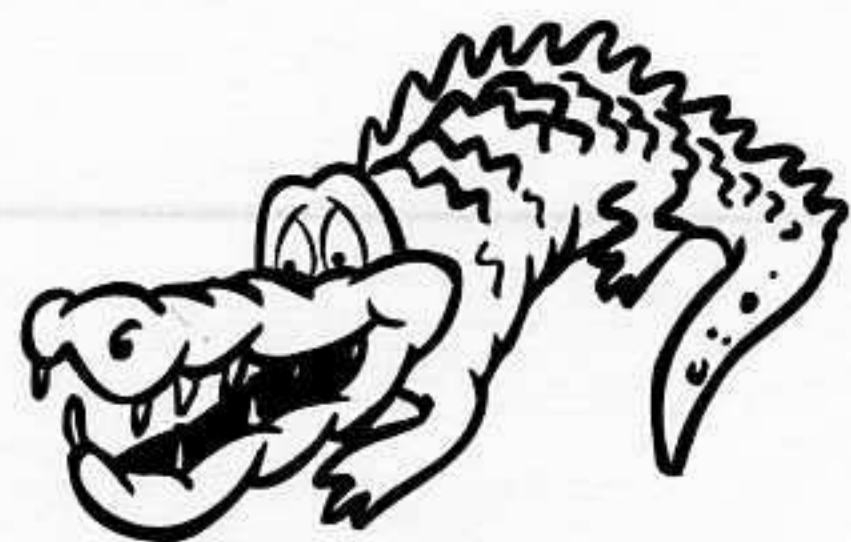

long I tail a haven't got

4 _____

T / F

Unit 3 Activity 8

Write.

1

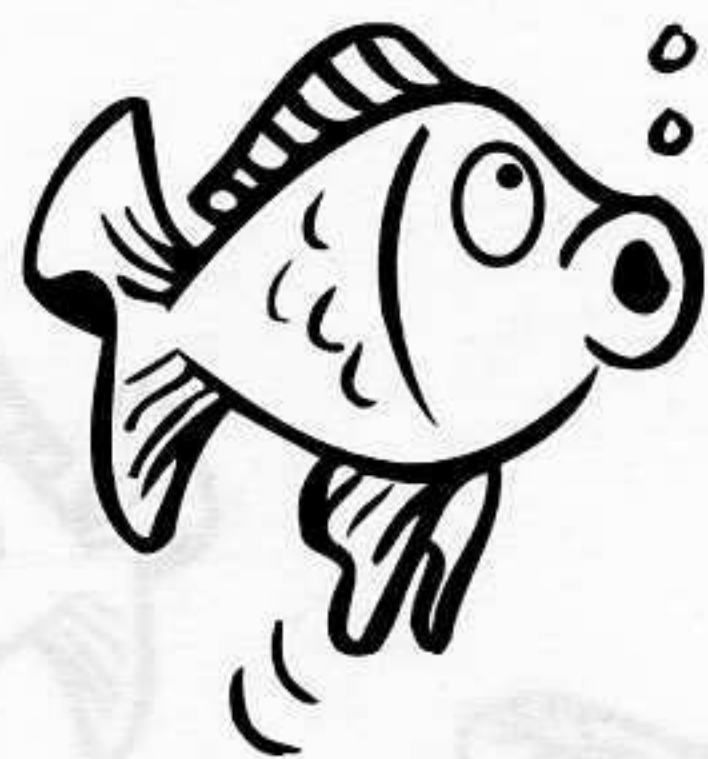

I've got two eyes.

I haven't got _____

2



I've got _____

3

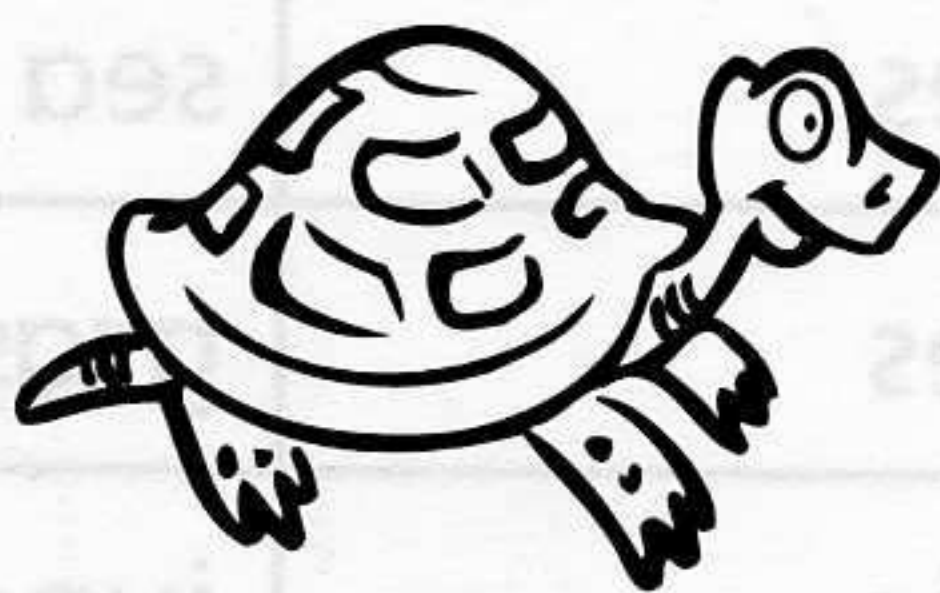

PHOTOCOPIABLE

Unit 3 Activity 9

Write *Yes, I have* or *No, I haven't*.



- 1 Have you got a dog? _____
- 2 Have you got a brother? _____
- 3 Have you got a sister? _____
- 4 Have you got blue jeans? _____
- 5 Have you got a yellow T-shirt? _____
- 6 Have you got a blue school bag? _____

Unit 3 Activity 10

Read and write the name of the animal.

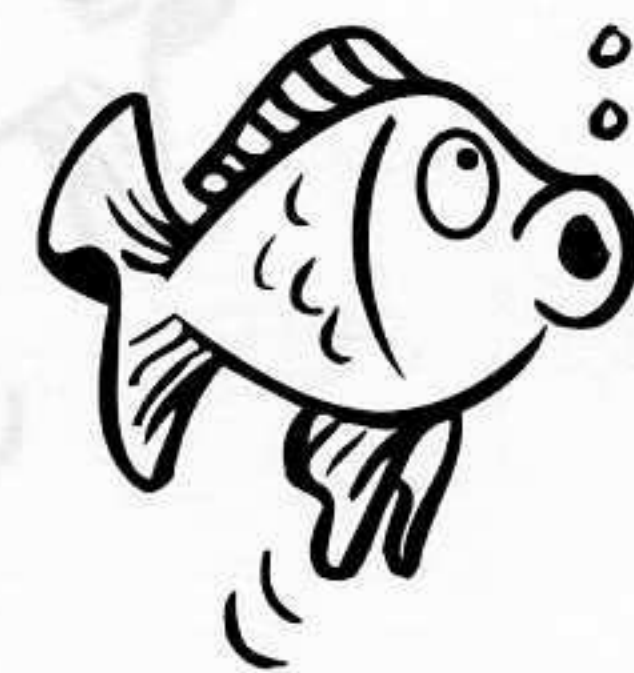

	LEGS	TAIL	WHISKERS	TEETH	LIVE
1 <u>tiger</u>	four	yes	yes	yes, big	jungle
2 _____	no	yes	no	yes	sea
3 _____	no	yes	no	yes	grasslands
4 _____	two	no	no	yes	jungle
5 _____	four	yes	yes	yes, big	jungle

Unit 3 Activity 11

Look and write.



1 Where's the tiger?

It's on the desk.

2 Where's the gorilla?

3 Where's the crocodile?

4 Where's the snake?

Unit 3 Activity 12

Read, look and write.



1 I've got a big brown body. gorilla

2 I've got big teeth and a big mouth. _____

3 I've got four legs. _____

4 I've got a long green body. _____

5 I've got a long tail. _____

6 I live in the jungle. _____

Unit 3 Activity 13

Write.



1

I live in _____
the jungle.

I _____

2

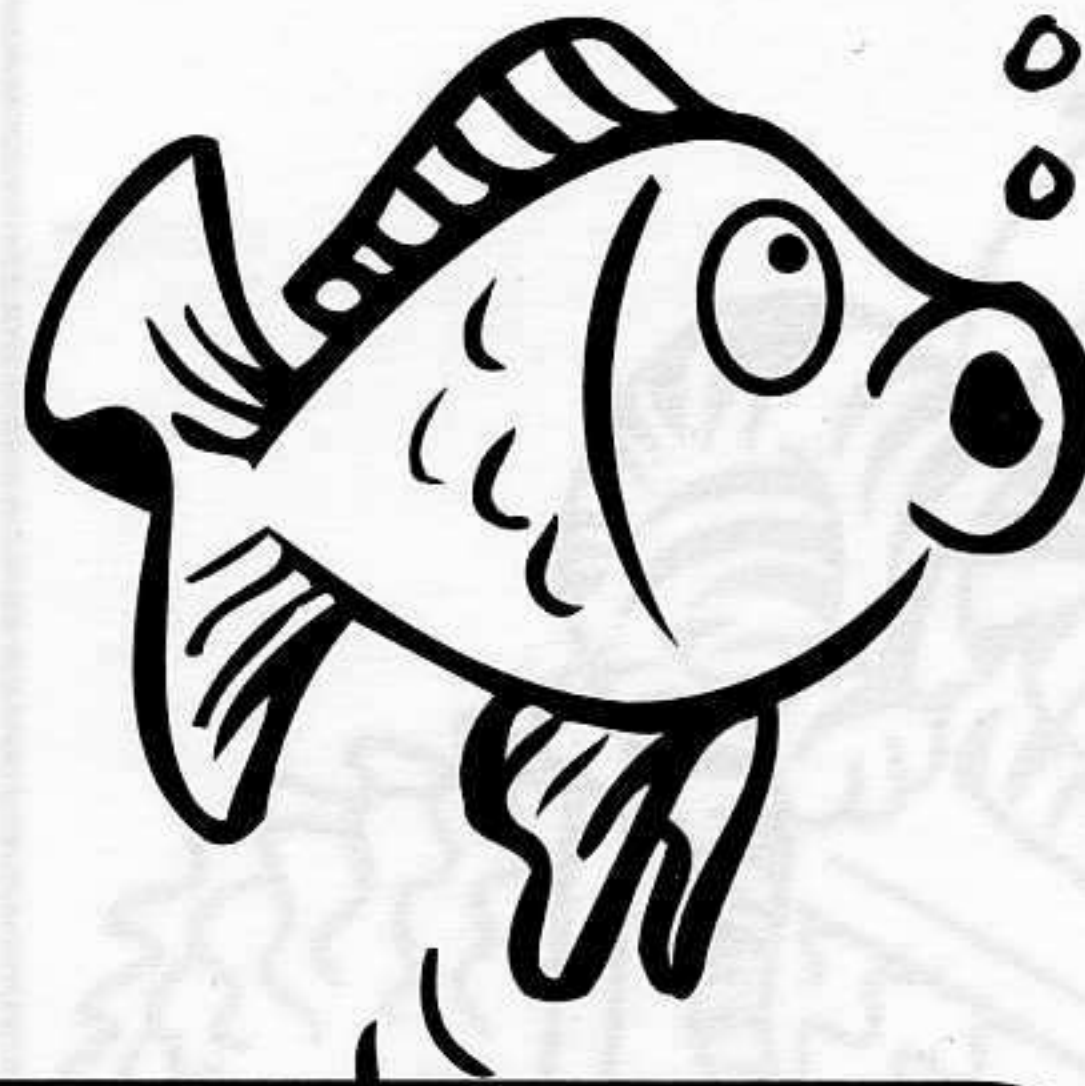

I _____

I _____

3

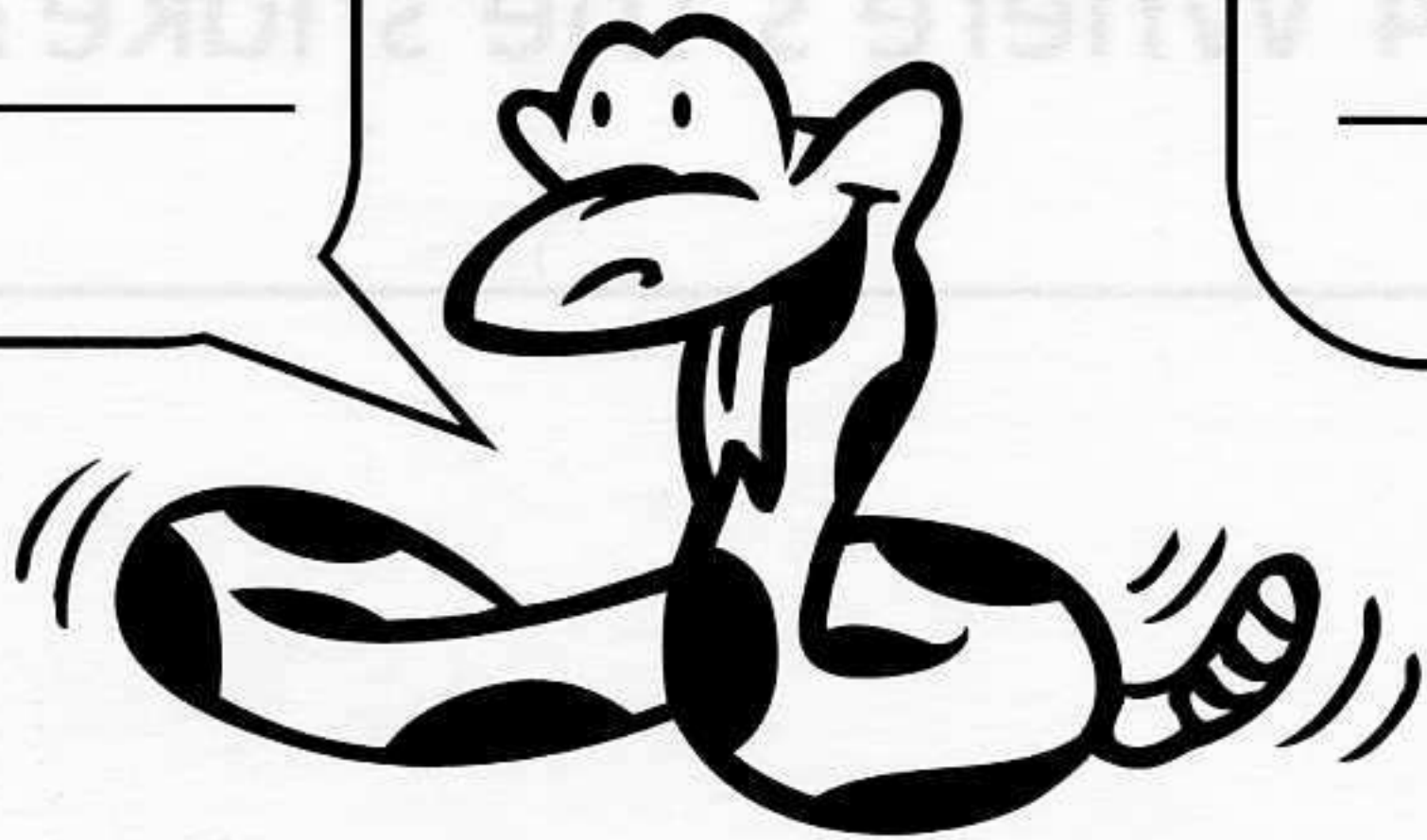

4

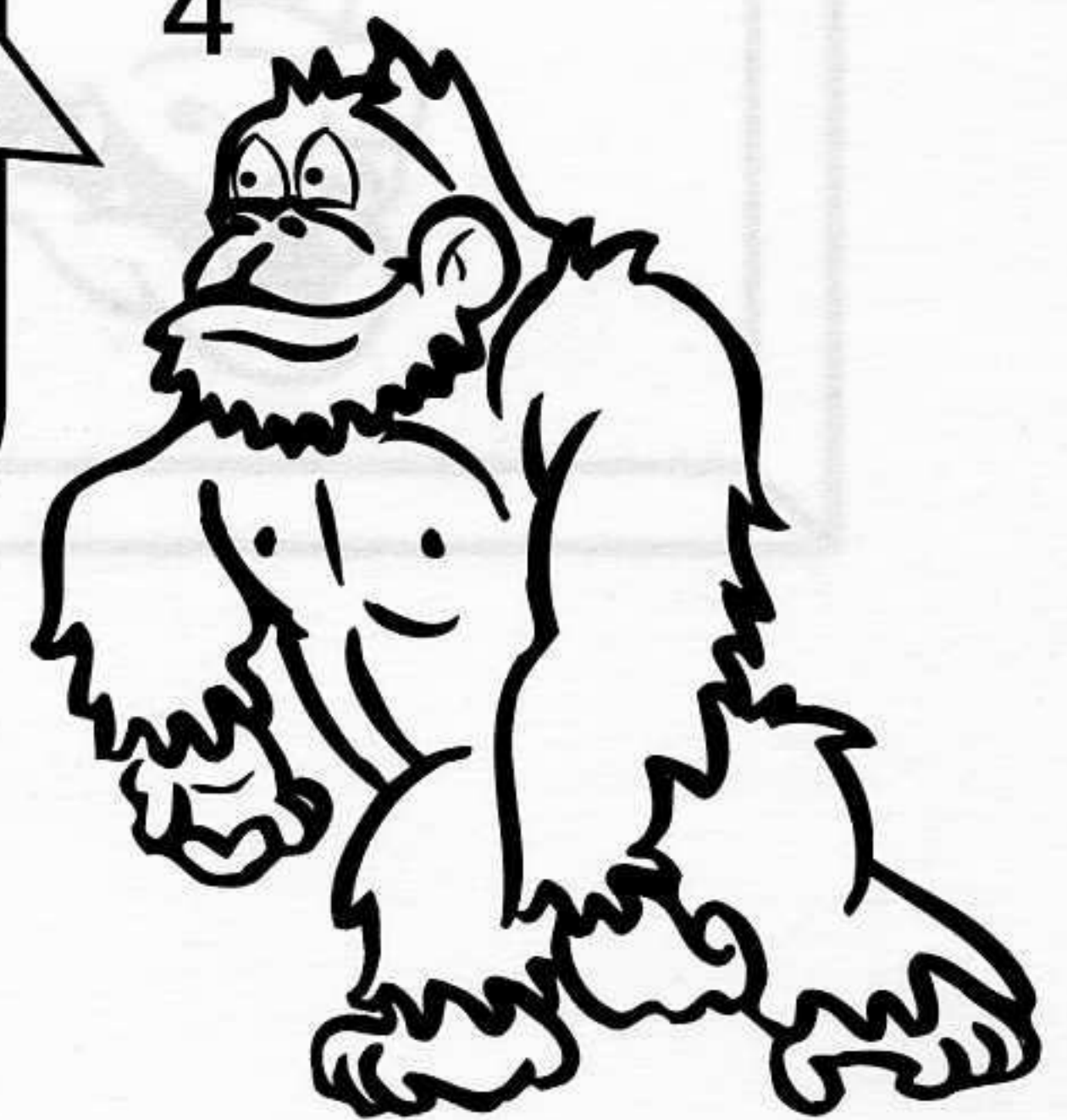

Unit 3 Activity 14

Read and write.

trainers crocodile nine six giraffe ~~ten~~ ~~hat~~
 one jeans bird whale coat gorilla three T-shirt

1 NUMBERS

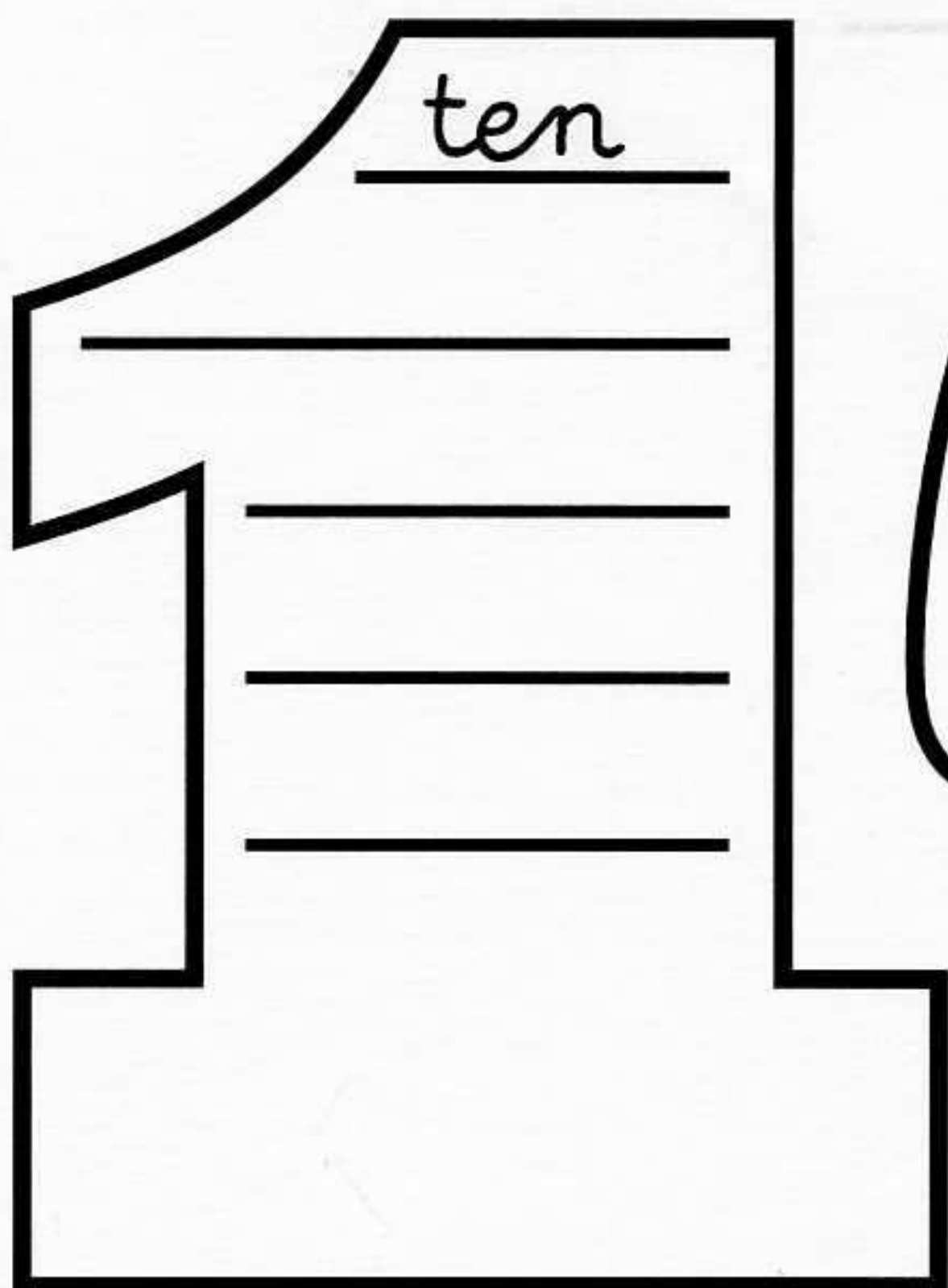

2 ANIMALS

3 CLOTHES

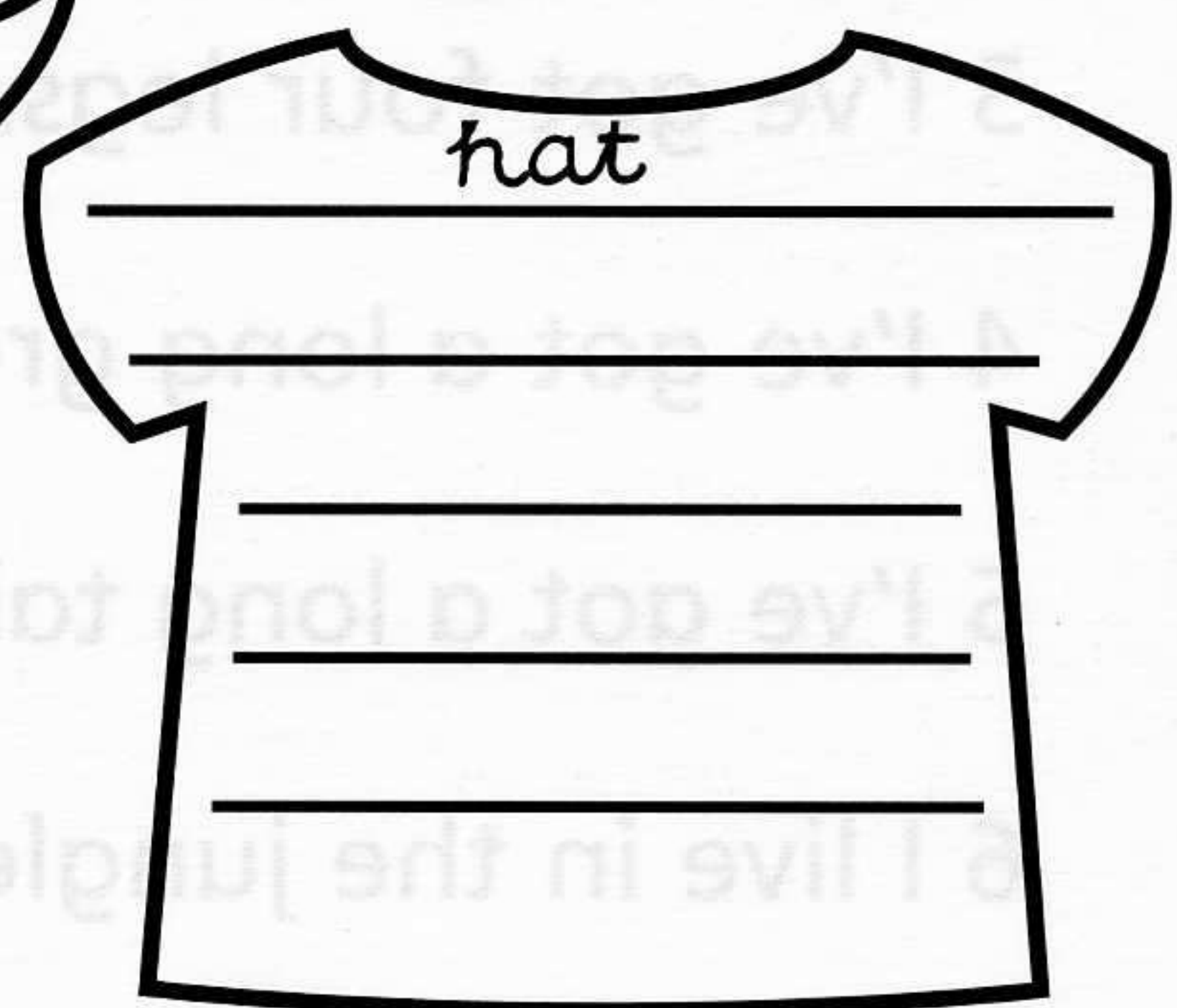

Unit 3 Activity 15

Read and match.

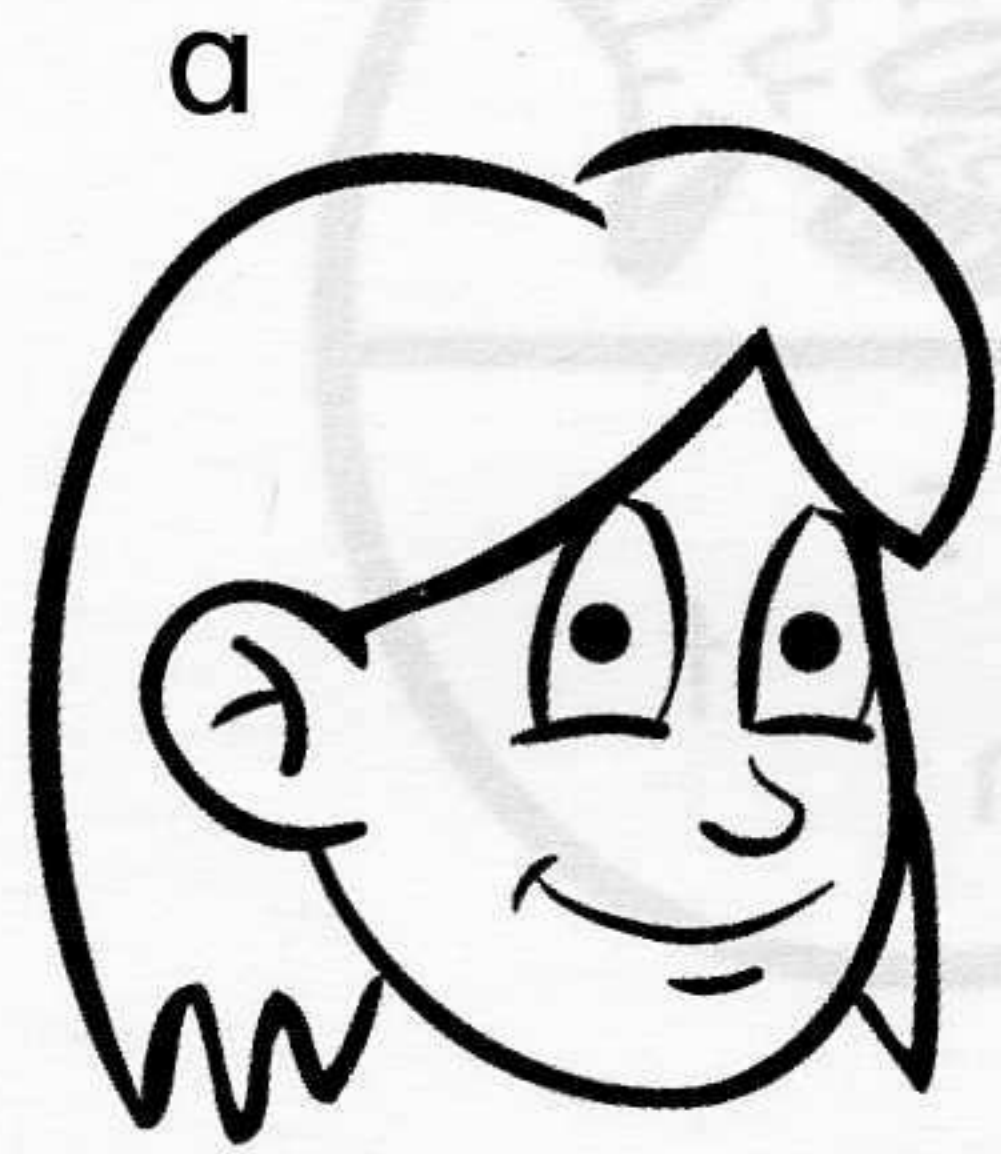

1 I've got a tail and whiskers. I'm yellow and black and I live in the jungle.

2 I've got a tail and a big body. I live in the sea.

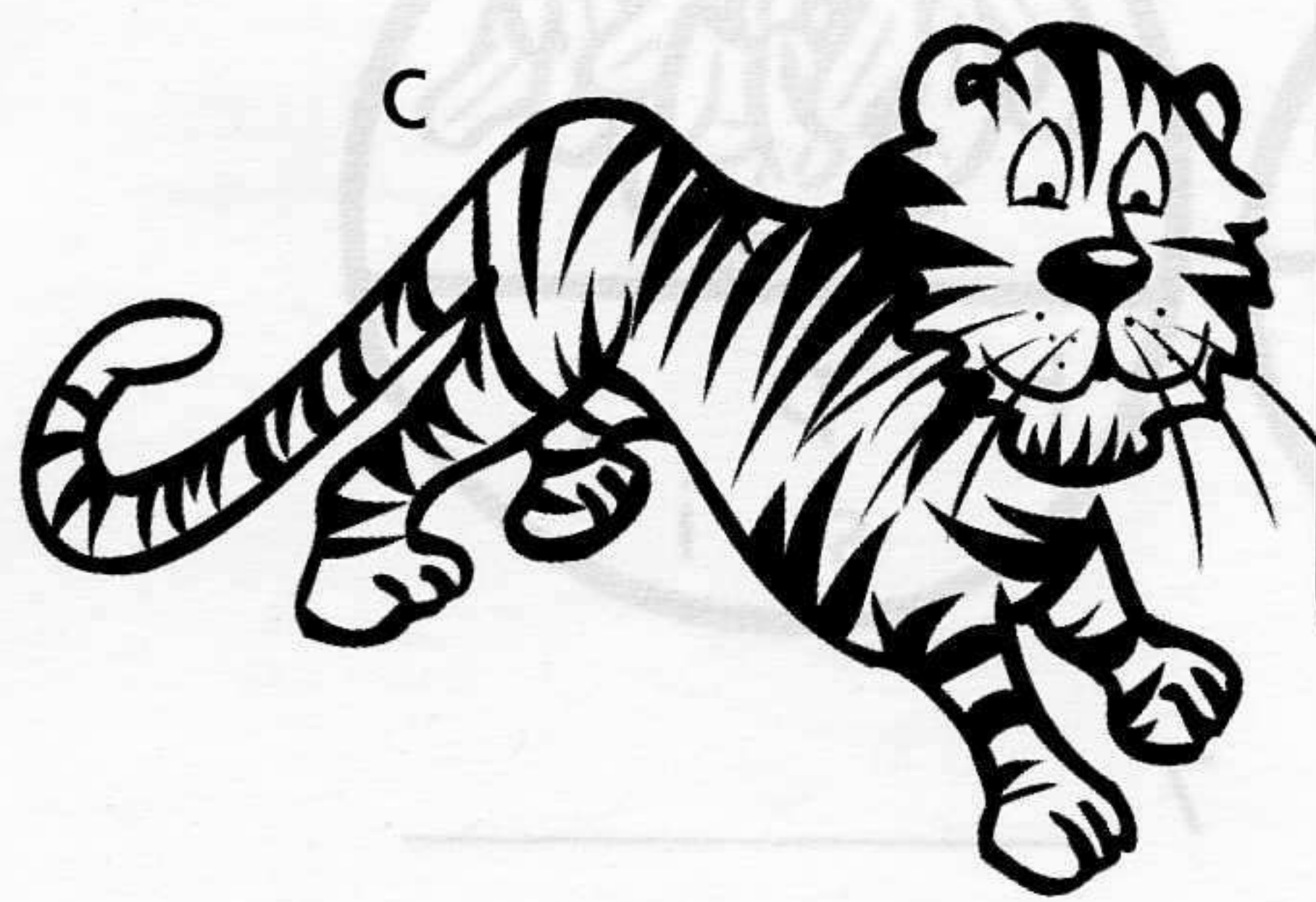

3 I've got four legs and a long tail. I'm green and I live in the jungle.

4 I've got two legs and two big eyes. I live in a house.

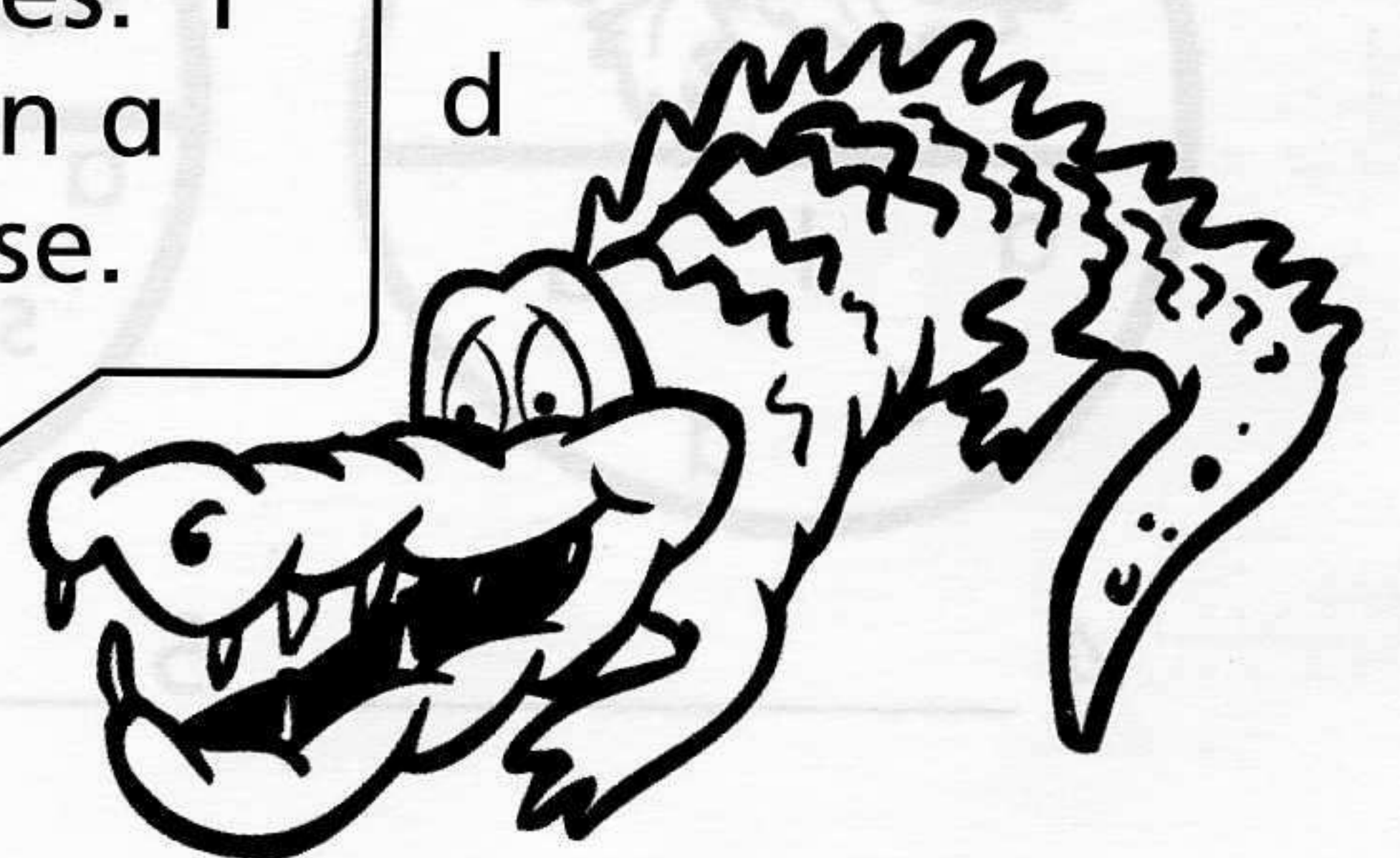

Unit 3 Activity 16

Read, draw and color

My name's Archie.
This is my family.
My mum's wearing a yellow T-shirt and blue jeans. Auntie Jane's wearing a red dress.
My sister's wearing a green T-shirt and blue jeans.
I'm wearing a red and blue T-shirt and blue jeans.

Auntie Jane

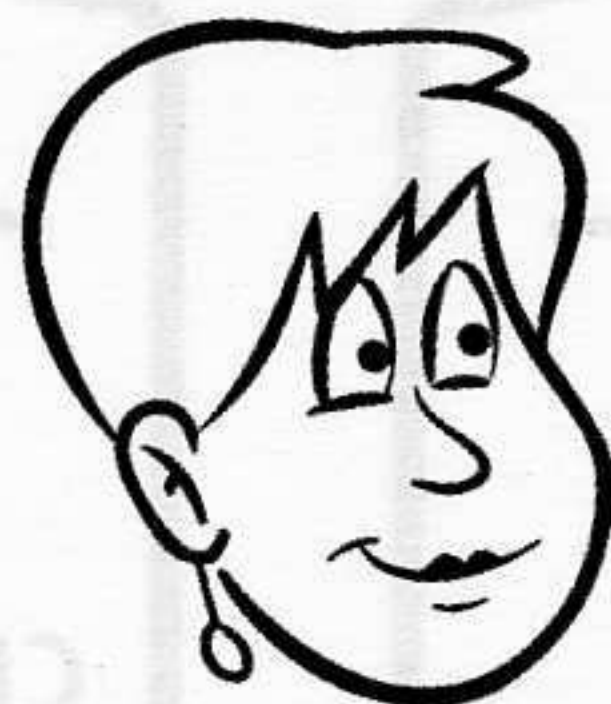

Mum



Me

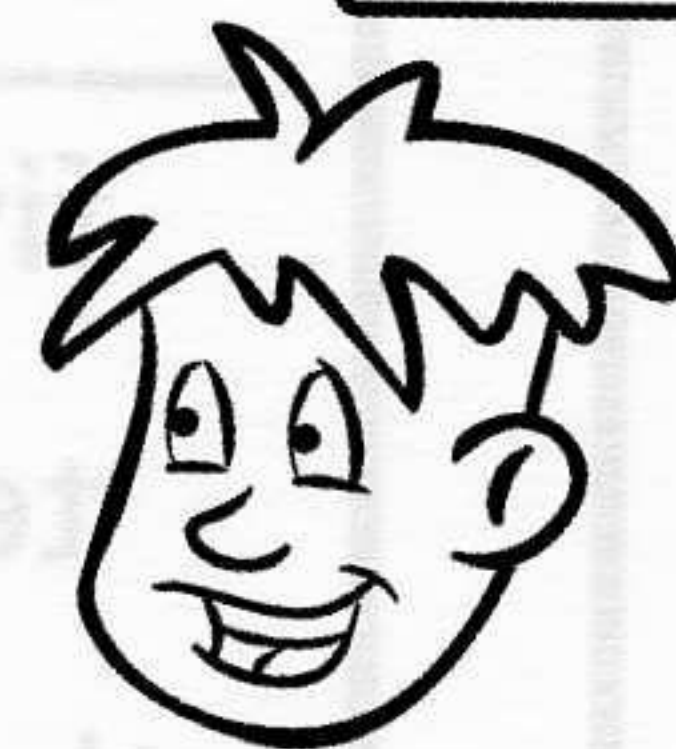

My Sister



PHOTOCOPIABLE

Unit 4 Activity 1

Write.

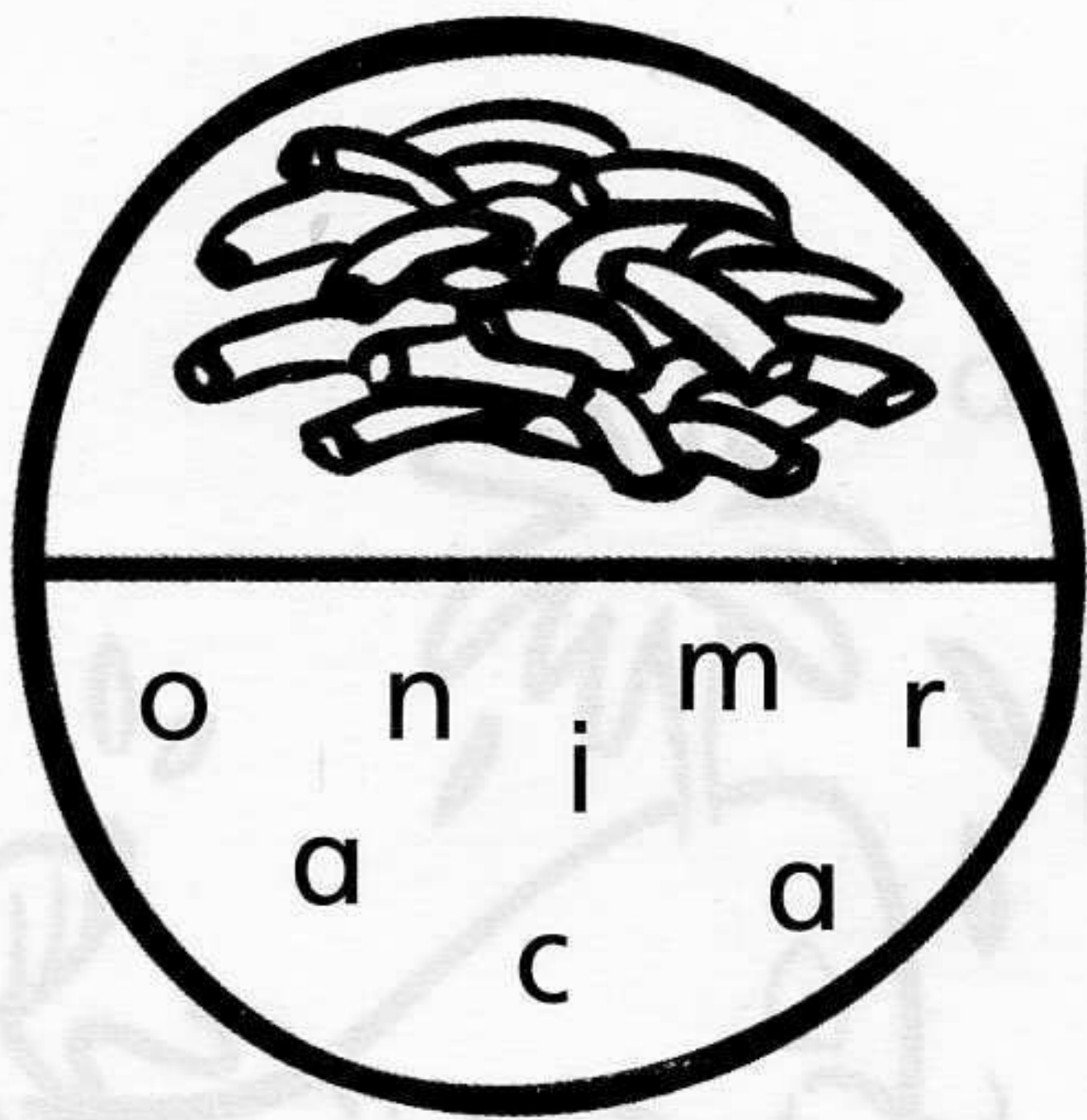

1 macaroni

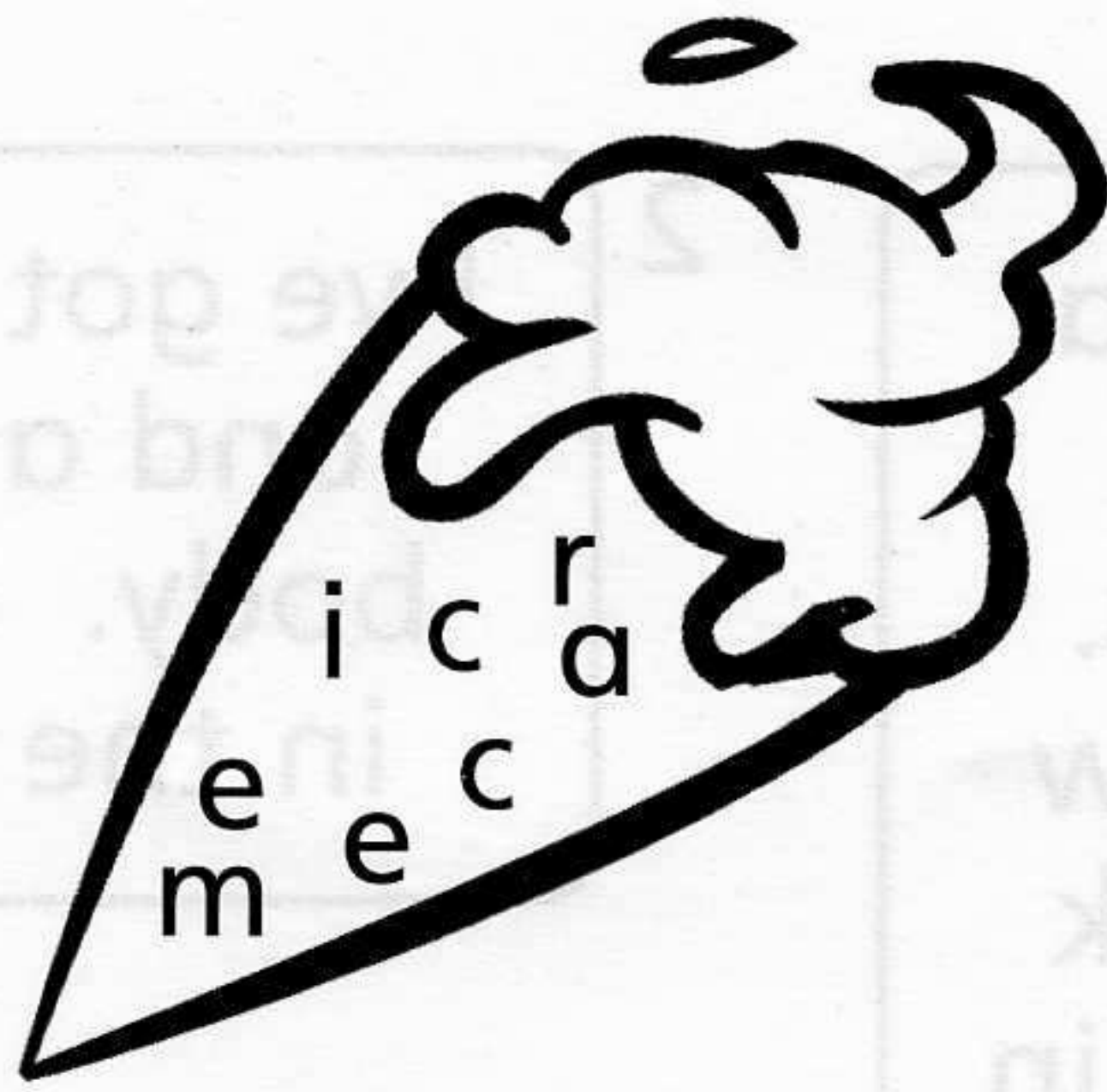

2 _____

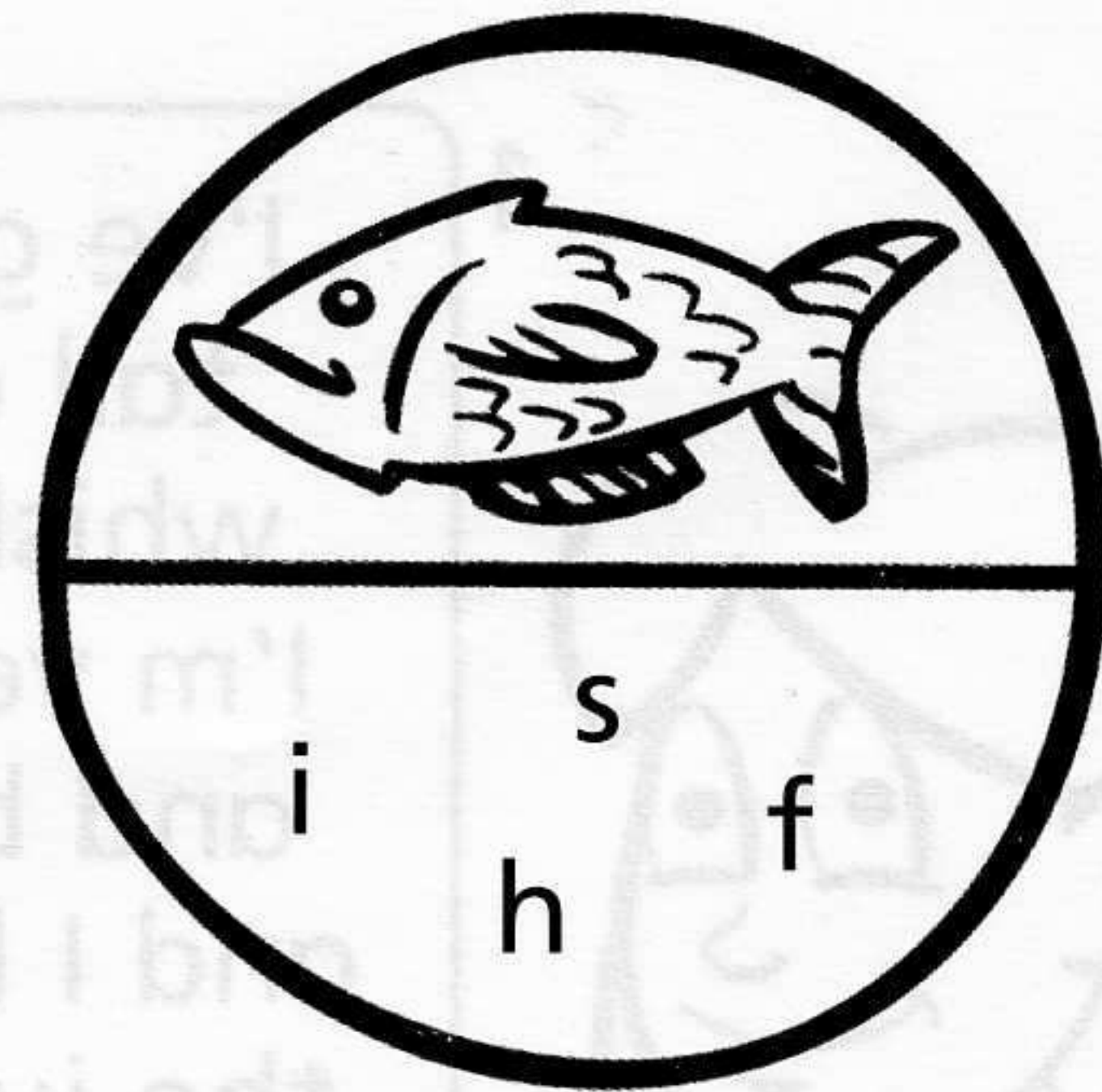

3 _____



4 _____

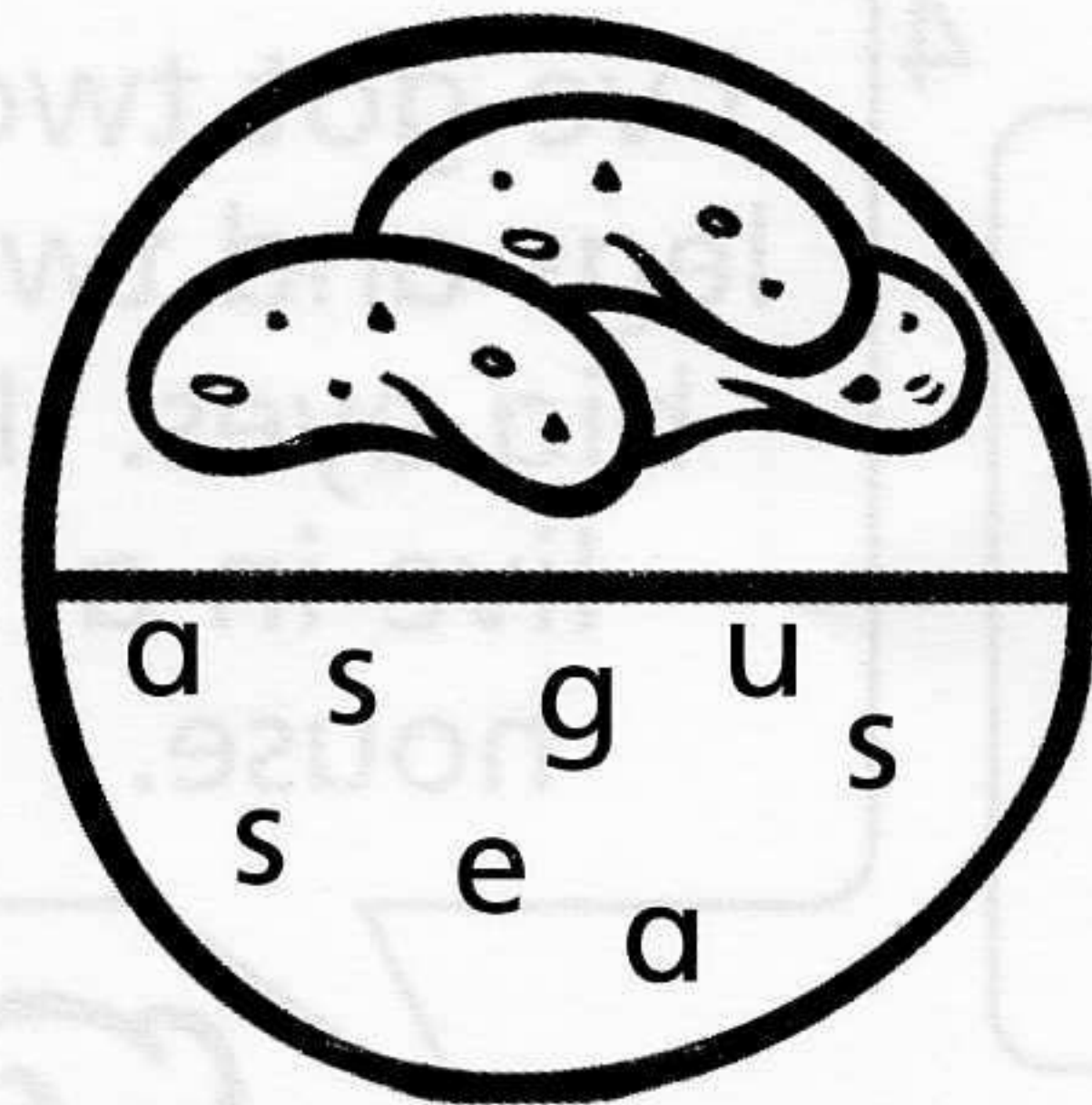

5 _____



6 _____

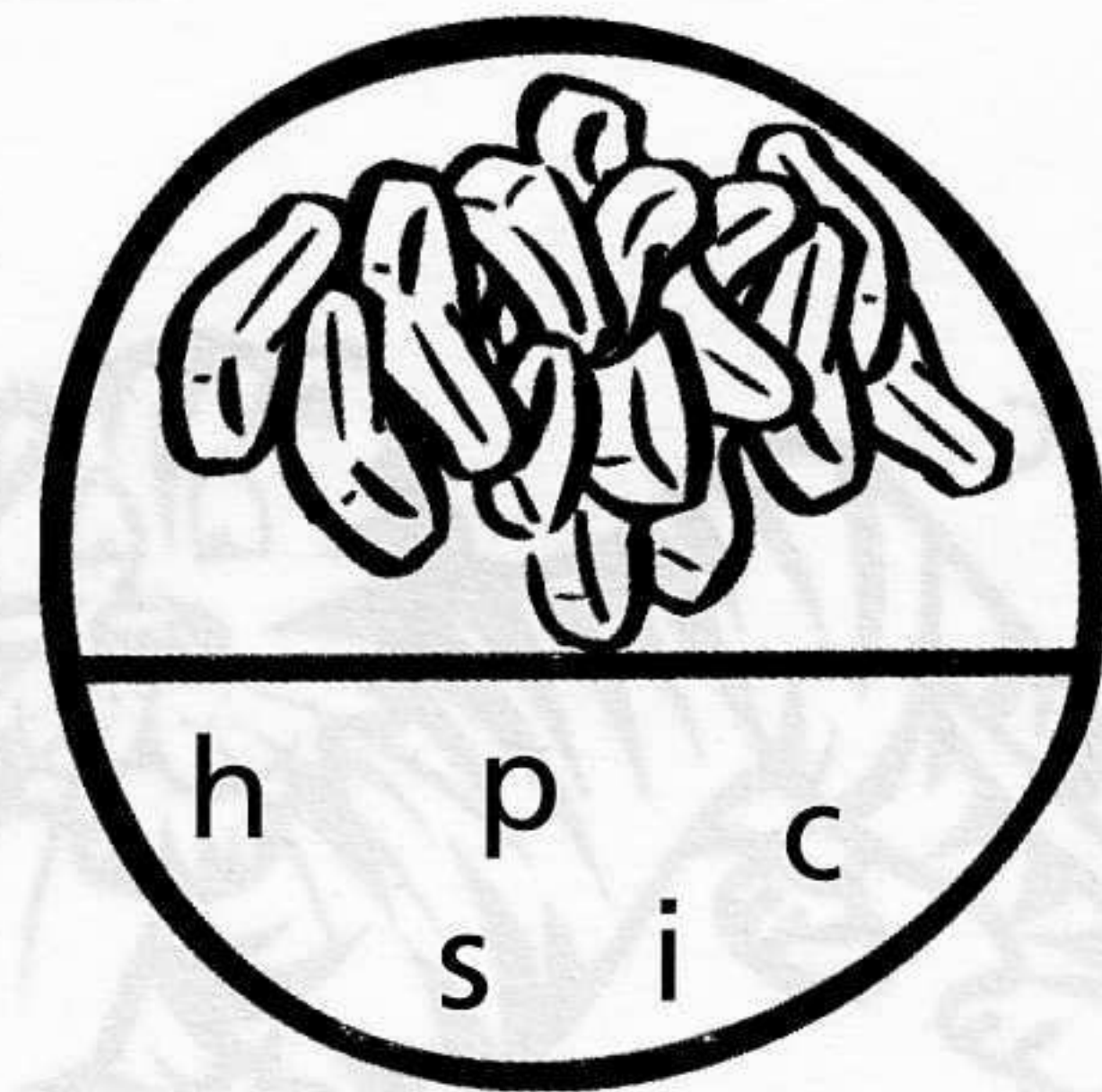

7 _____

Unit 4 Activity 2

Read and write. Circle the different word.

1

Clothes

dress

hat

jeans

trainers

knife

coat

2

five

ten

three

eleven

black

twenty

thirteen

3

pen

pencil

rice

school bag

rubber

ruler

chair

4

snake

crocodile

gorilla

chips

tiger

leopard

zebra

5

white

blue

black

red

pink

fish

orange

green

school animals ~~clothes~~ numbers colours

Unit 4 Activity 3

Look and circle.

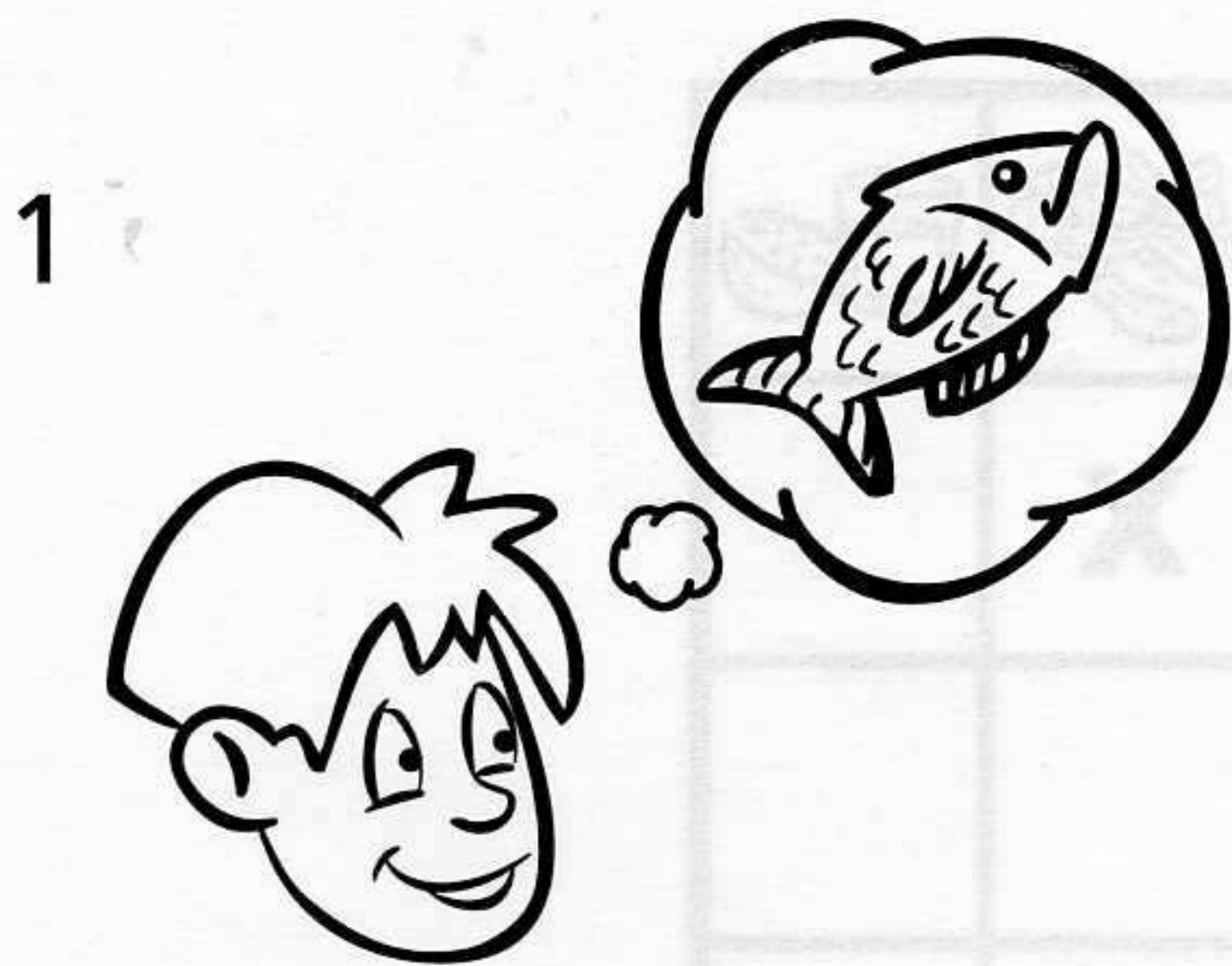

I like fish.
I don't like



I like ice cream.
I don't like

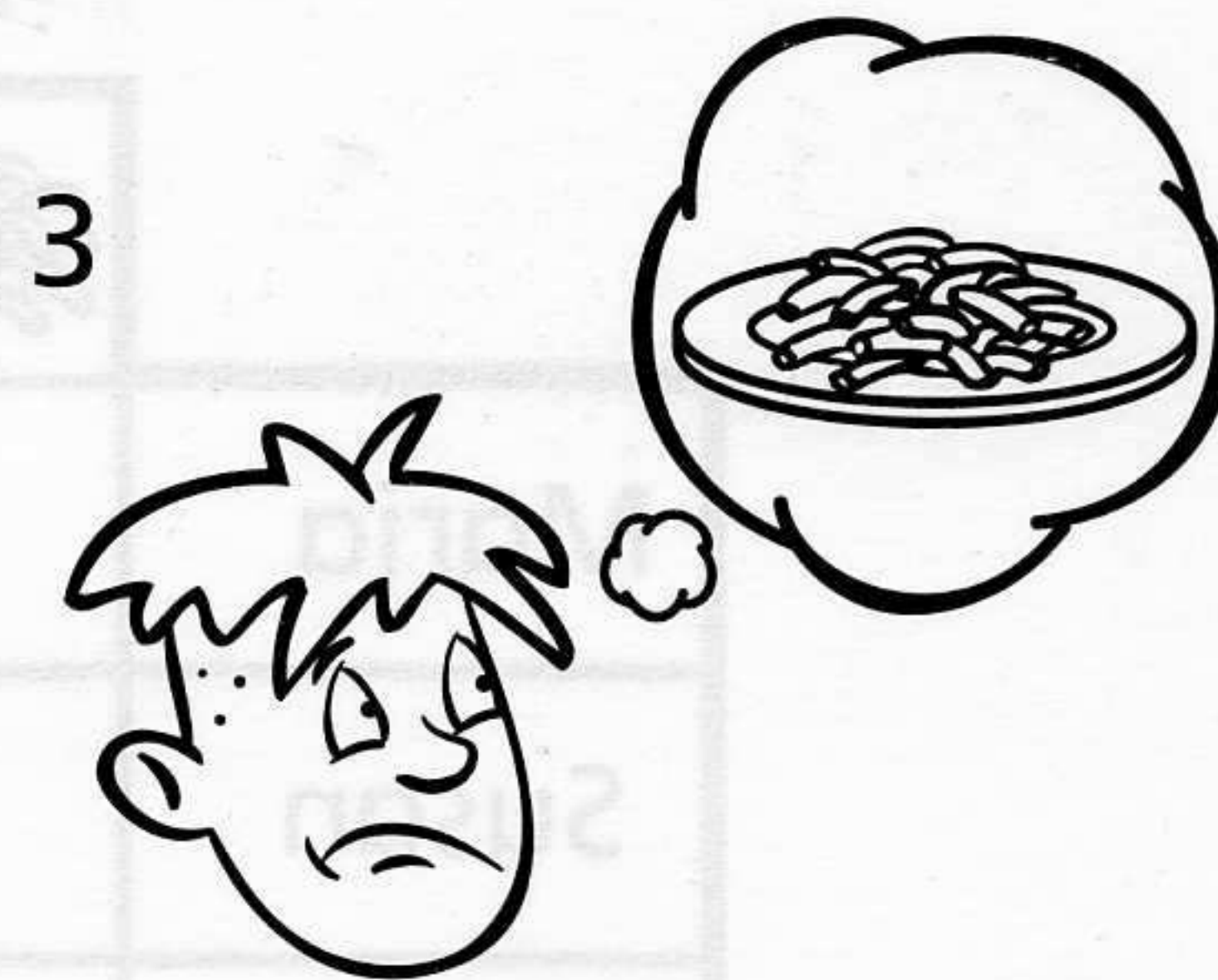

I like macaroni.
I don't like

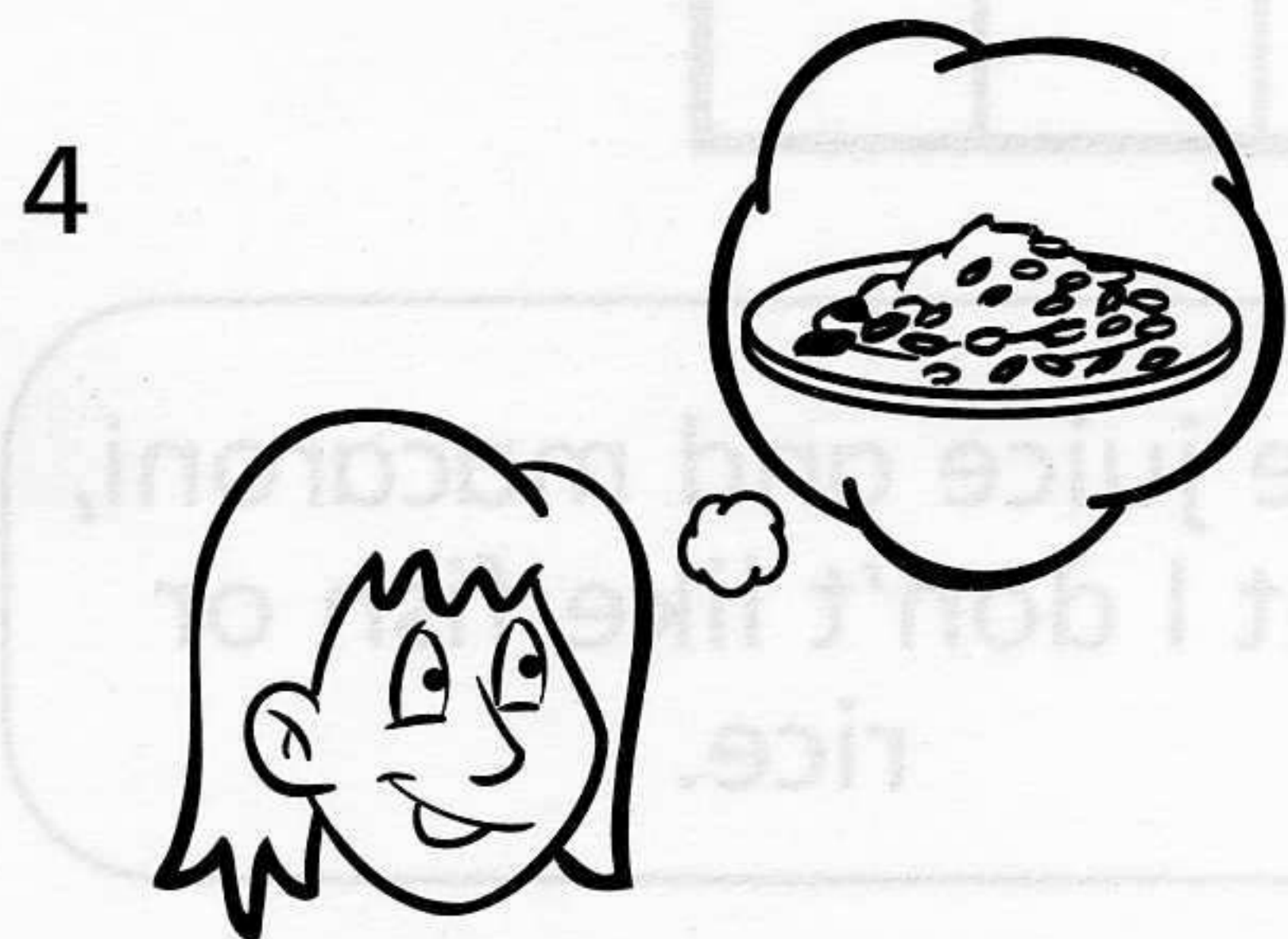

I like rice.
I don't like

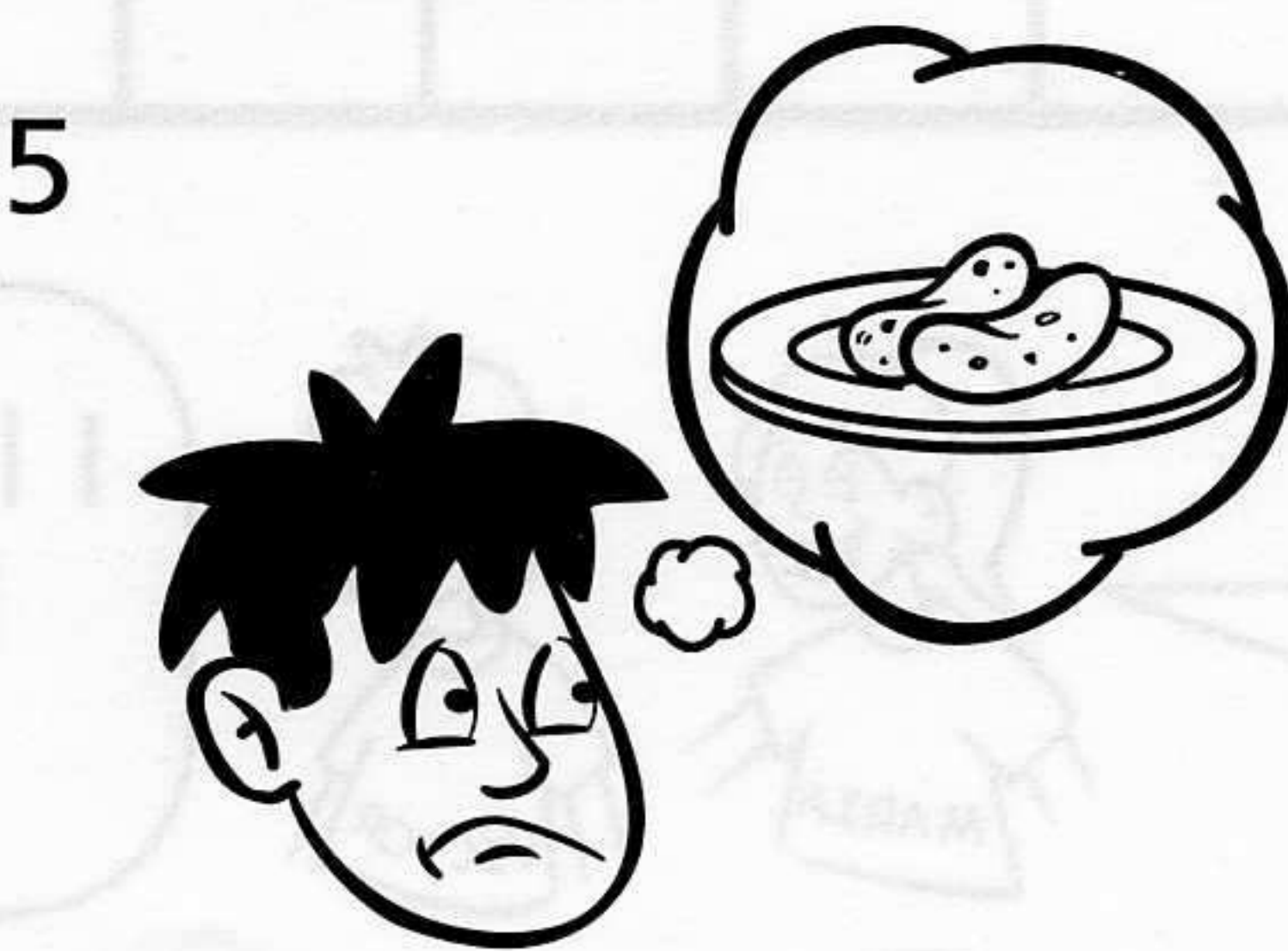

I like sausages.
I don't like

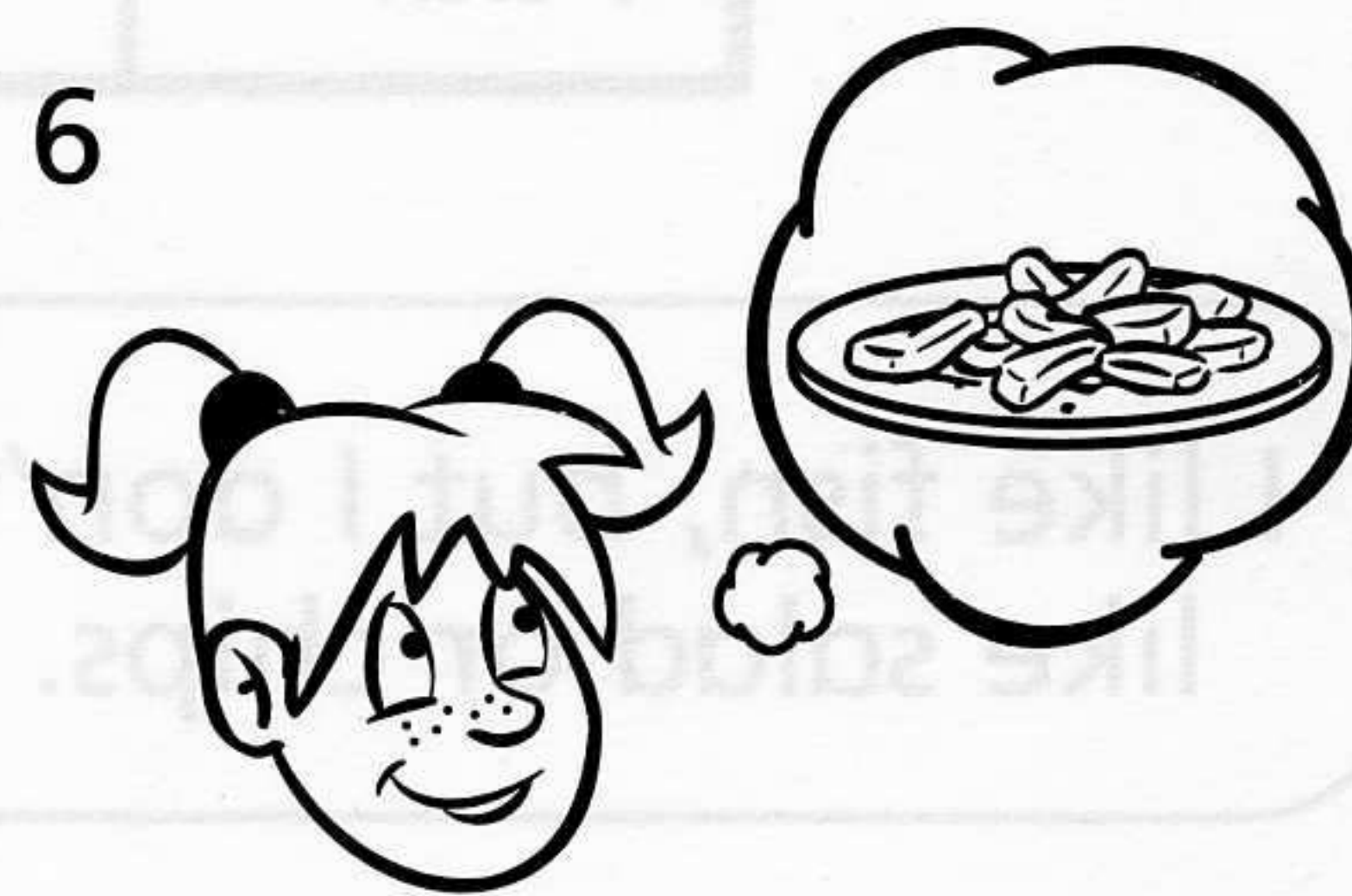

I like chips.
I don't like

Unit 4 Activity 4

Find and write.

1 I like chips.

2 _____

3 _____

4 _____







5 _____

PHOTOCOPIABLE

Unit 4 Activity 5

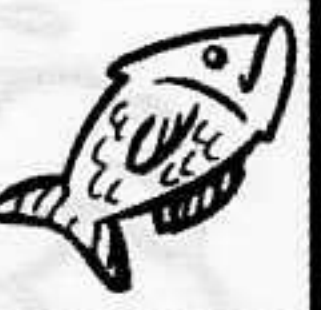
Read and write (✓) or (X).

✓ = I like X = I don't like

							
Maria			✓	X			X
Susan							
Victor							
Paul							

I like fish, but I don't like salad or chips.



I like juice and macaroni, but I don't like fish or rice.

I like salad and sausages, but I don't like rice or chips.



I like salad and ice cream, but I don't like macaroni or sausages.

Unit 4 Activity 6

Order and write.

1

don't I like sausages

I don't like sausages.

2

like I chips and fish

3

salad and juice I like

4

don't macaroni I like

5

ice cream and like rice I

Unit 4 Activity 7

Read and write A or B.

A



B



- 1 She's got sausages on her plate.
- 2 She's wearing a dress.
- 3 She's got fish and chips on her plate.
- 4 She's wearing a T-shirt.
- 5 She's wearing jeans.
- 6 She's wearing a hat.

A

Unit 4 Activity 8

Write.

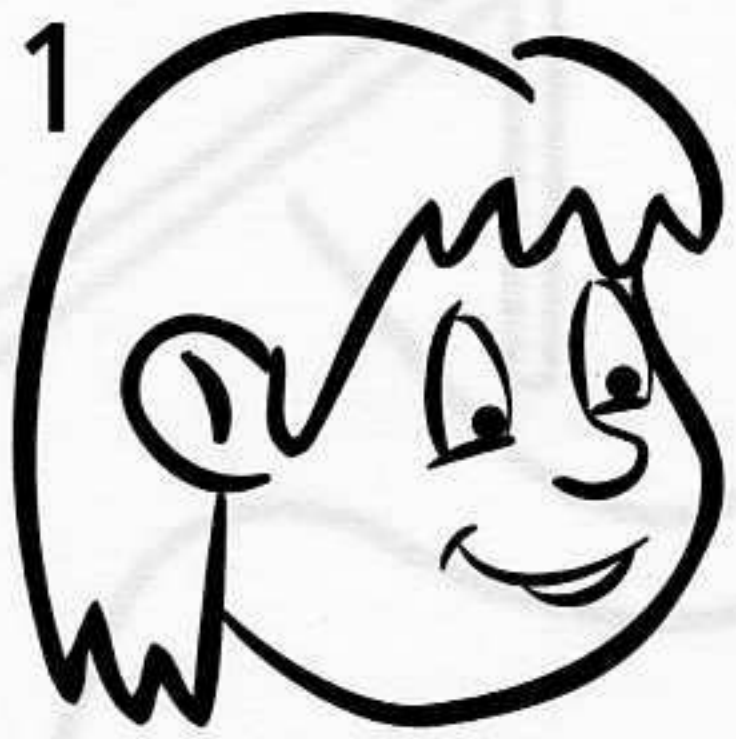

Do you like _____ fish?

Yes, I do.

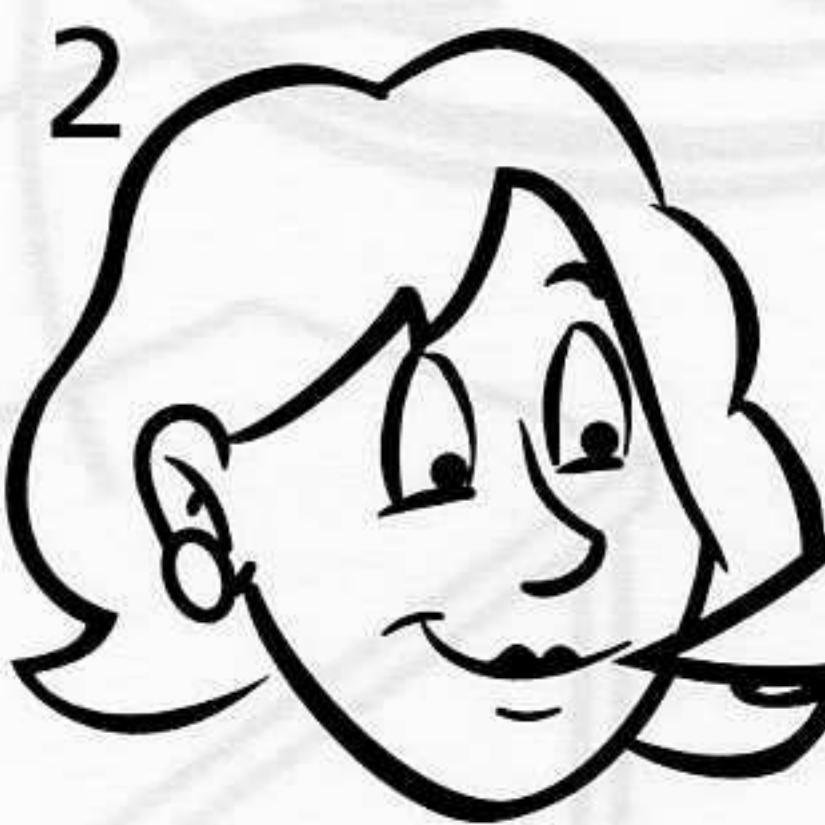

_____ ice cream?

No, I don't.

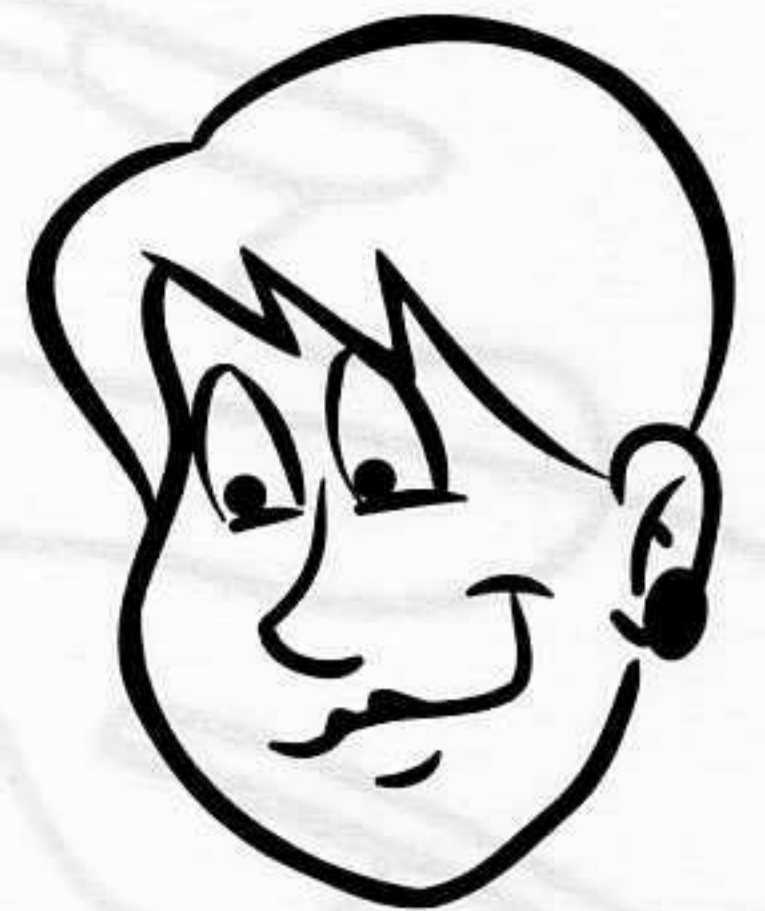

_____ rice?

Yes, _____

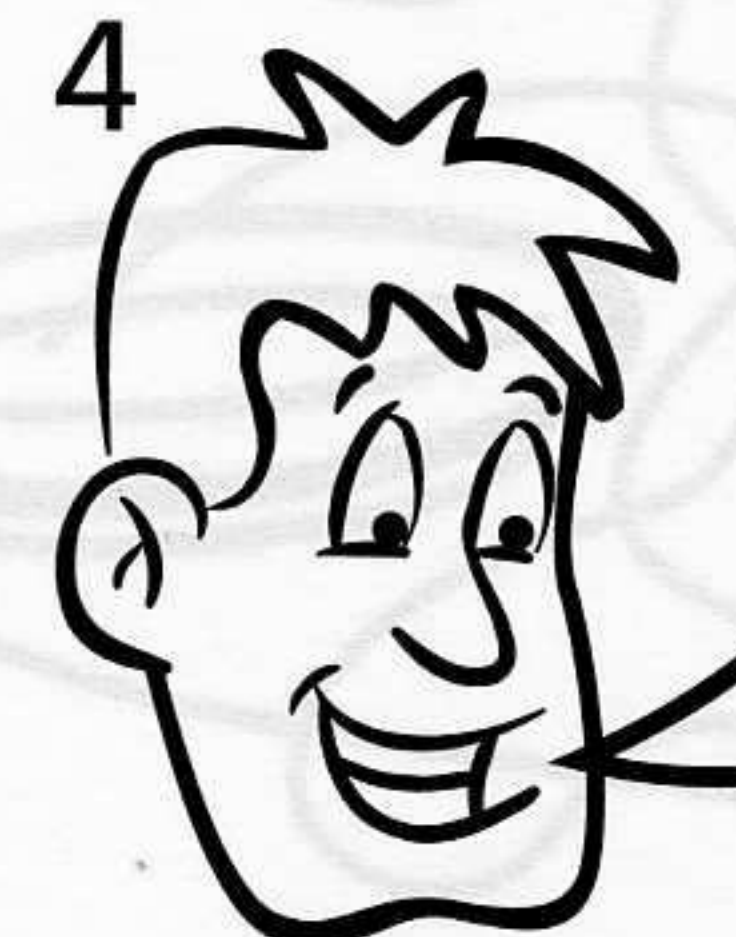

_____ chips?

No, _____



PHOTOCOPIABLE

Unit 4 Activity 9

Write. Find the secret word.

A crossword puzzle grid with the following structure:

- Row 1: 5 squares. The 2nd square contains the number 3. The 4th square contains the number 1.
- Row 2: 5 squares. The 3rd square is empty. The 4th square is empty. The 5th square is empty.
- Row 3: 5 squares. The 1st square is empty. The 2nd square is empty. The 3rd square is empty. The 4th square contains the number 2. The 5th square contains the number 4.
- Row 4: 5 squares. The 1st square is empty. The 2nd square is empty. The 3rd square is empty. The 4th square is empty. The 5th square is empty.
- Row 5: 5 squares. The 1st square is empty. The 2nd square is empty. The 3rd square is empty. The 4th square is empty. The 5th square is empty.

Illustrations and arrows:

- A glass with an arrow pointing to the 1st square of Row 1.
- A spoon with an arrow pointing to the 4th square of Row 1.
- A plate with an arrow pointing to the 3rd square of Row 2.
- A fork with an arrow pointing to the 1st square of Row 3.
- A knife with an arrow pointing to the 1st square of Row 5.

The secret word is
 1 2 3 4

Unit 4 Activity 10

Find and write.

A maze with five numbered paths leading to different objects:

- 1 Where's the plate?
It's on the table.
- 2 Where's the knife?
- 3 Where's the fork?
- 4 Where's the spoon?
- 5 Where's the glass?

Unit 4 Activity 11

Find and write.

1



Can I have _____
_____ and
_____ please?

2



_____ and
_____ please?

3

_____?



Unit 4 Activity 12

Read and number.

1

I've got a knife,
a fork and a plate.

2

I've got two plates,
a glass, a knife and a spoon.

3

I've got two glasses,
a knife, a fork, a plate
and a spoon.

4



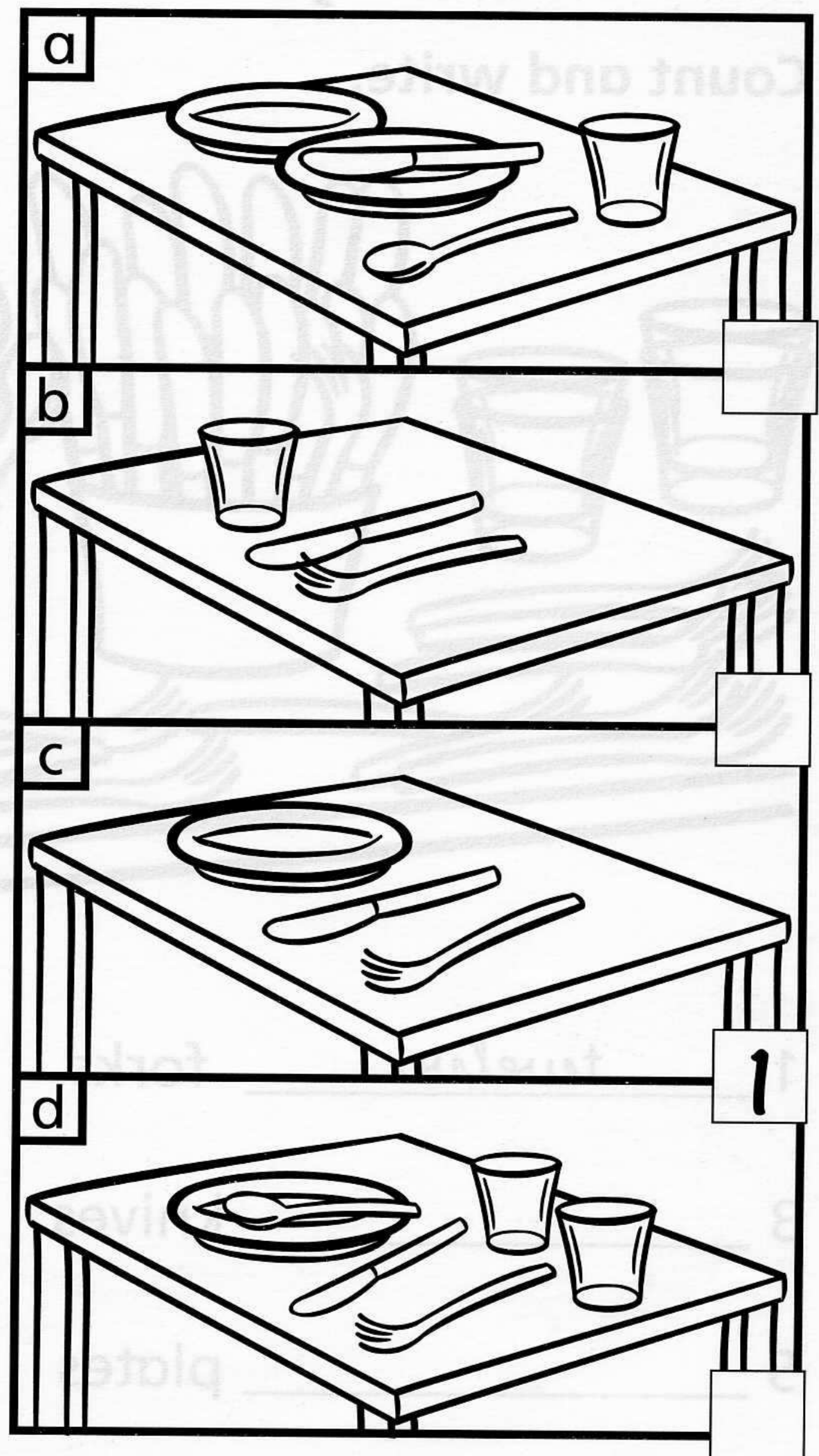





I've got a knife,
a fork and a glass.



Unit 4 Activity 13

Write.

~~Daniel~~ ice cream tail nine rice
salad dog fish macaroni

I'm  Daniel. I'm . My favourite colour is blue. I've got a . It's brown and white. It's got a long . I like  and . I don't like  or . My favourite is .

Unit 4 Activity 14

Count and write.

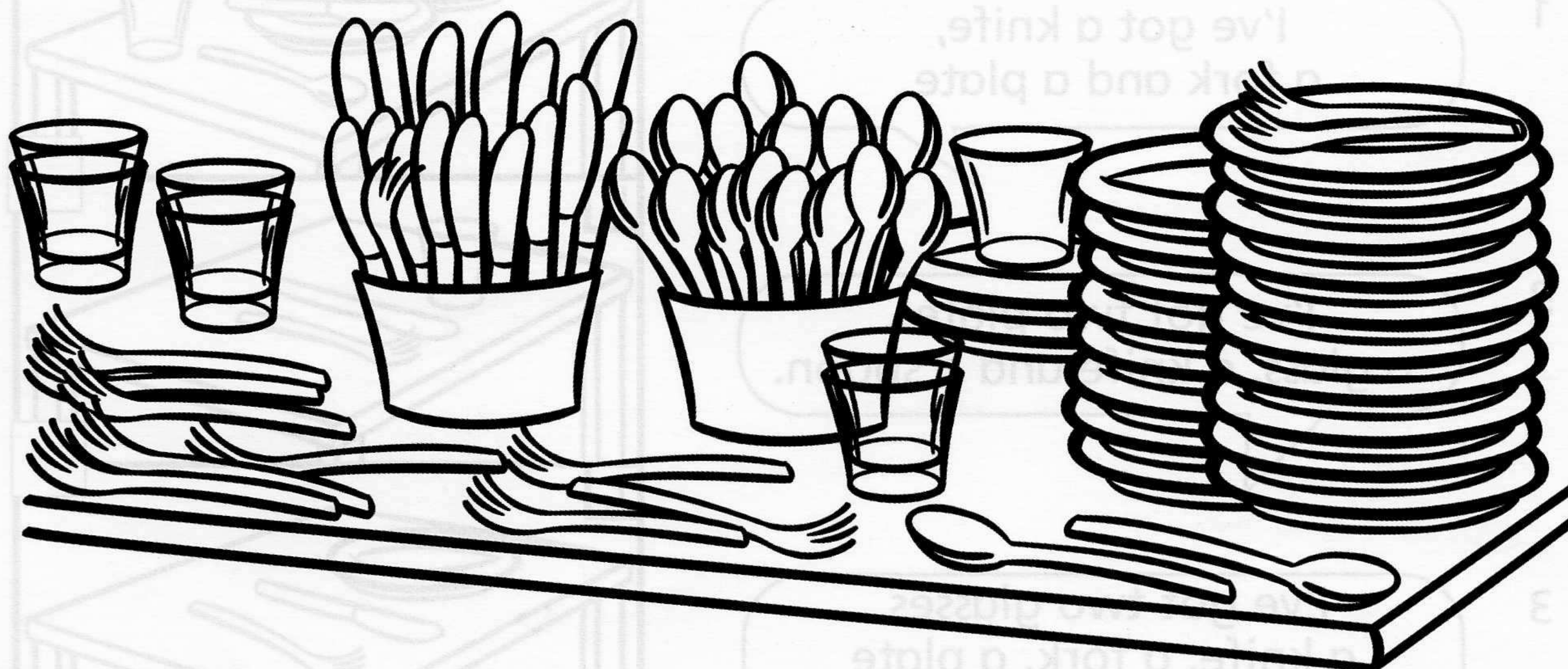

1 twelve forks

2 _____ spoons

3 _____ knives

4 _____ glasses

5 _____ plates

Unit 4 Activity 15

Read, look and write true (T) or false (F).



BRENDA



PAUL



SARAH



BEN

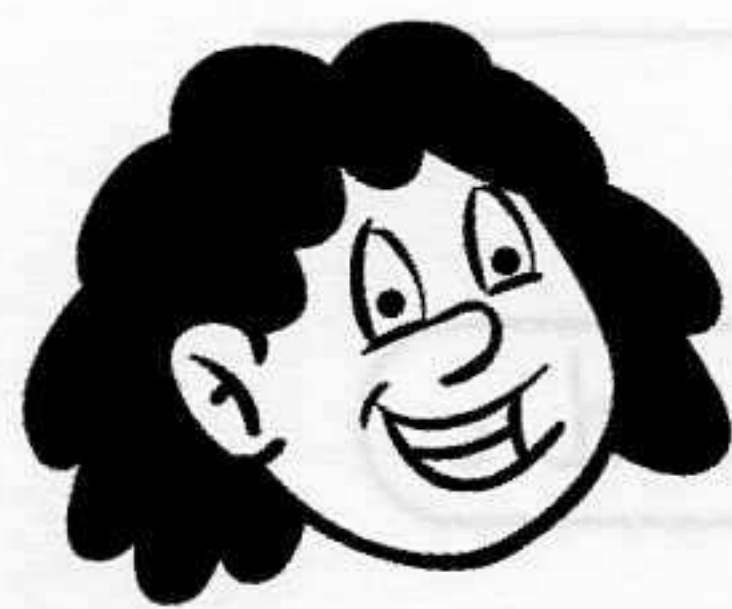

I'm Brenda. I've got fish and salad on my plate.

F



I'm Paul. I've got macaroni and ice cream on my plate.



I'm Sarah. I've got fish and rice on my plate.



I'm Ben. I've got macaroni and chips on my plate.

Unit 4 Activity 16

Write.

1 Where do tigers live? In the jungle.

2 Where do fish live? _____

3 What are you wearing? _____

4 Where do you live? _____

5 Do you like macaroni? _____

6 Have you got a brother? _____

7 Have tigers got whiskers? _____

PHOTOCOPIABLE

Unit 5 Activity 11

Read and draw.

1	2	3	4
I've got a long tail and a big mouth. I'm green. I live in the jungle.	I've got whiskers and big teeth. I live in the jungle.	I've got a long body, two small eyes and a long tongue.	I've got a big black body and eight legs.

Unit 5 Activity 12

Write.

- 1 twelve, fourteen, sixteen, _____, _____, _____, twenty-four
- 2 ten, _____, twenty, _____, thirty, thirty-five, _____
- 3 eight, twelve, sixteen, _____, twenty-four, _____, thirty-two, _____
- 4 eleven, _____, fifteen, _____, nineteen, twenty-one, _____
- 5 seven, _____, twenty-one, twenty-eight, _____, forty-two, _____
- 6 six, twelve, _____, twenty-four, _____, _____, forty-two

Unit 5 Activity 1

Write the sports.

stieynapnl



ostrakeabd



oalpflolybta



1 play tennis

2 _____

3 _____

rkaeiebid



lbalpatebkylas



eralolbledr



4 _____

5 _____

6 _____

Unit 5 Activity 2

Read and match.



1 I can swim.



2 I can play tennis.



4 I can play football.



5 I can rollerblade.



6 I can ride a bike.



7 I can play basketball.

Unit 5 Activity 3

Write.

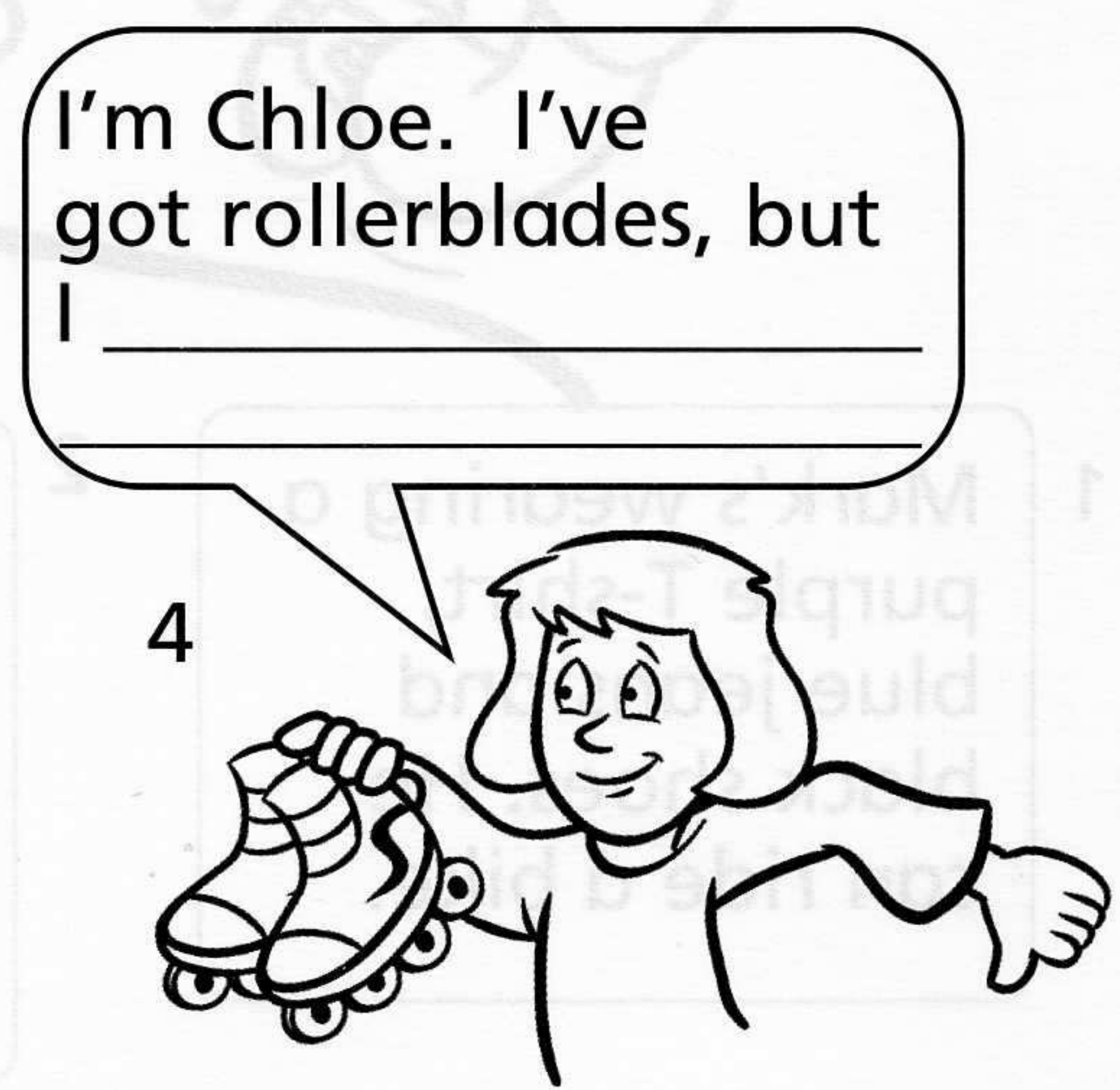
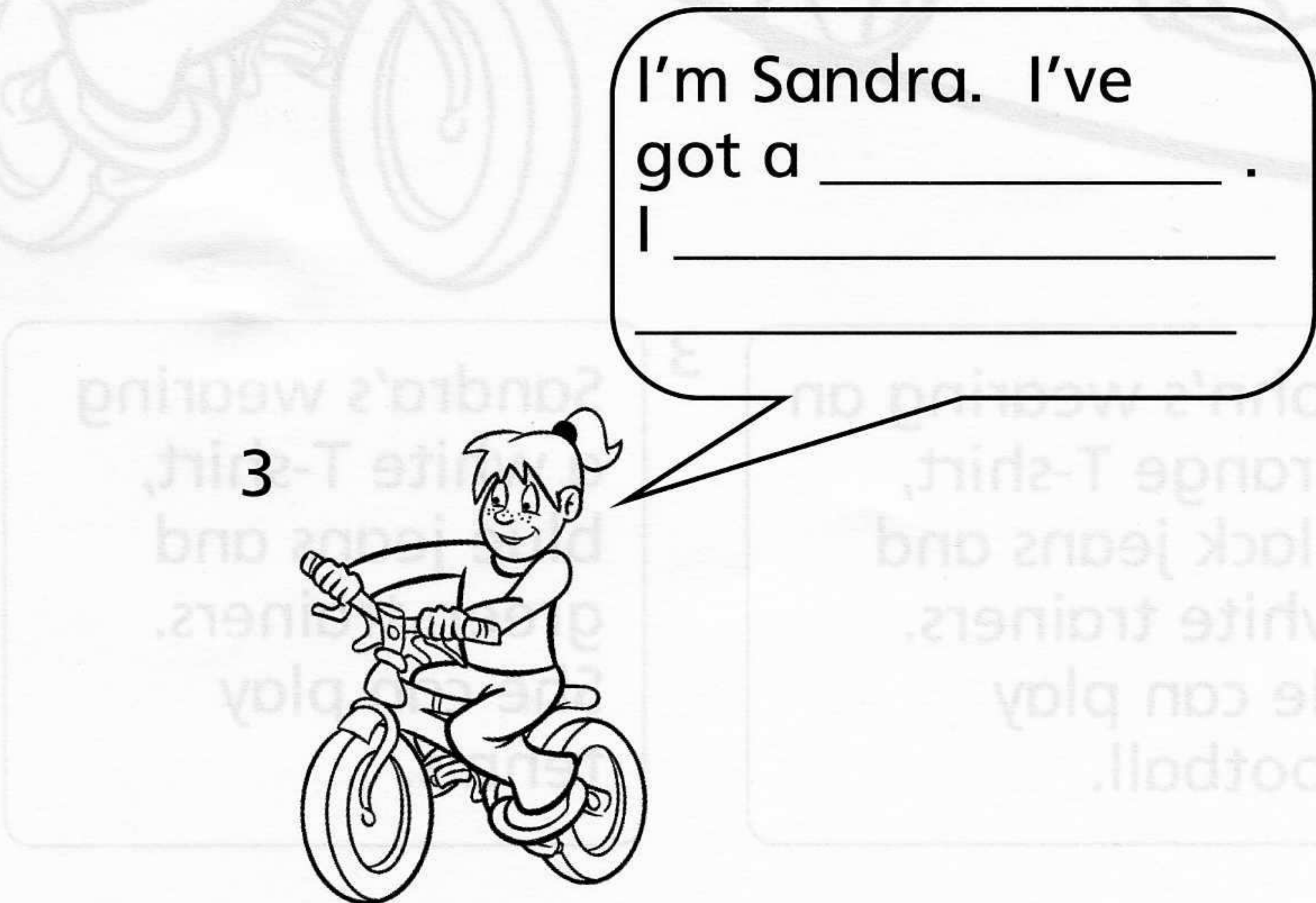
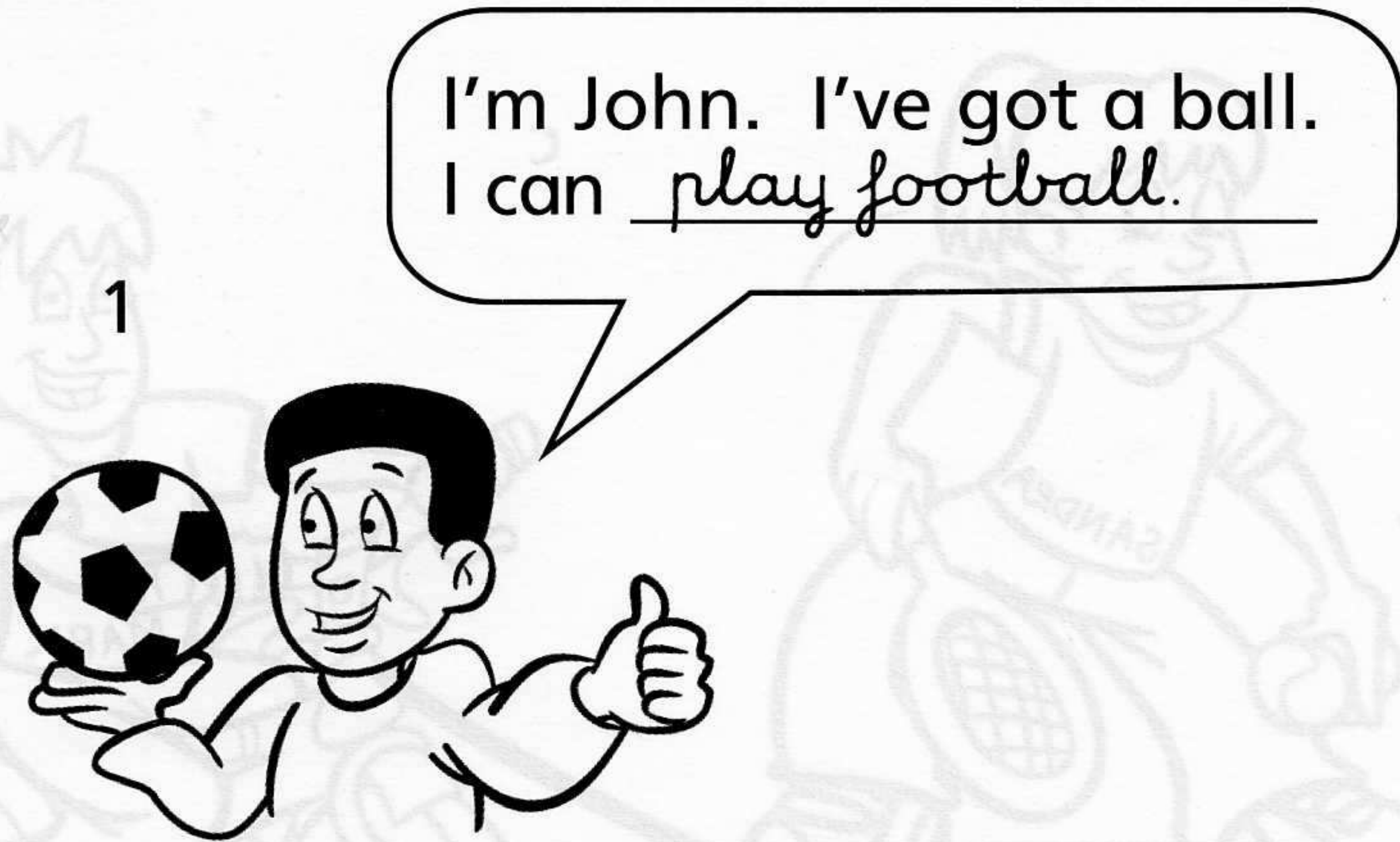

Unit 5 Activity 4

Find and write.

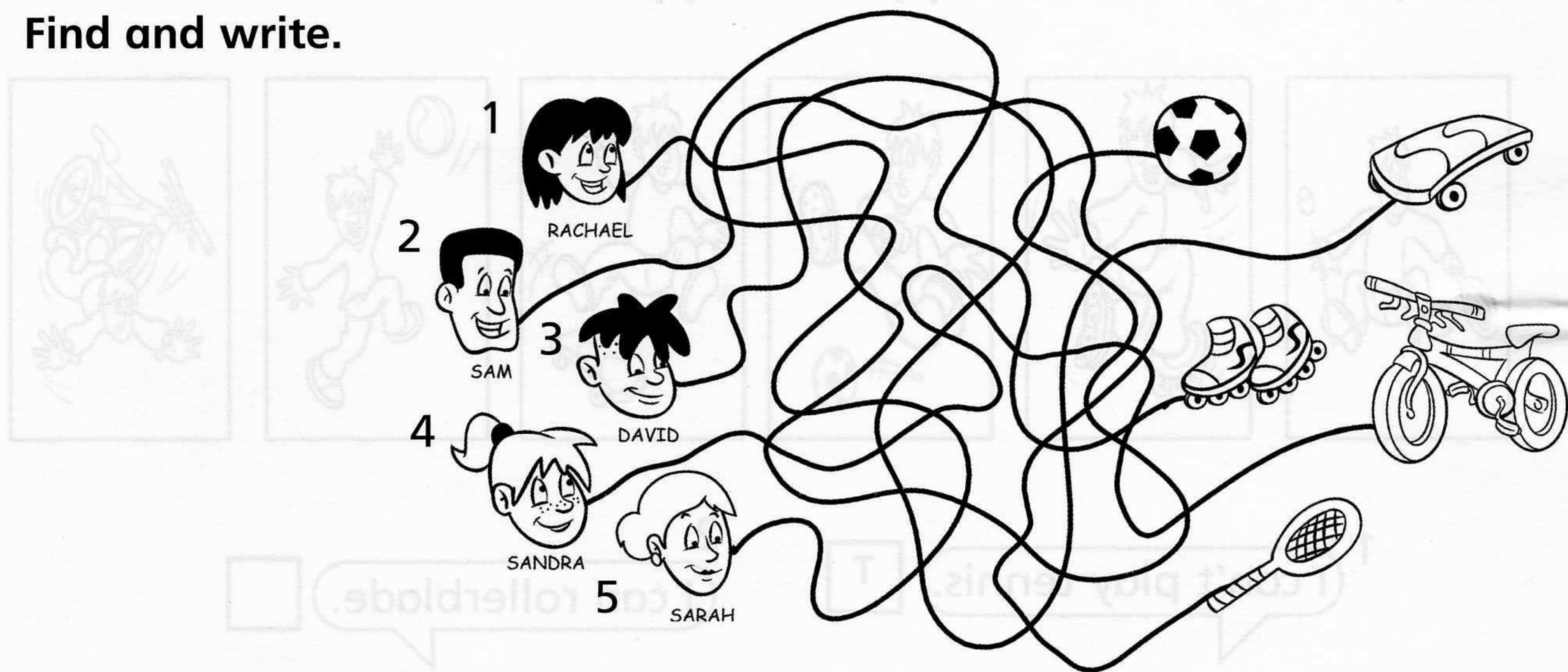

- | | | | |
|---|----------------|-----|-----------------------|
| 1 | <u>Rachael</u> | can | <u>play football.</u> |
| 2 | _____ | can | _____ |
| 3 | _____ | can | _____ |
| 4 | _____ | can | _____ |
| 5 | _____ | can | _____ |

PHOTOCOPIABLE

Unit 5 Activity 5

Read, match and colour.

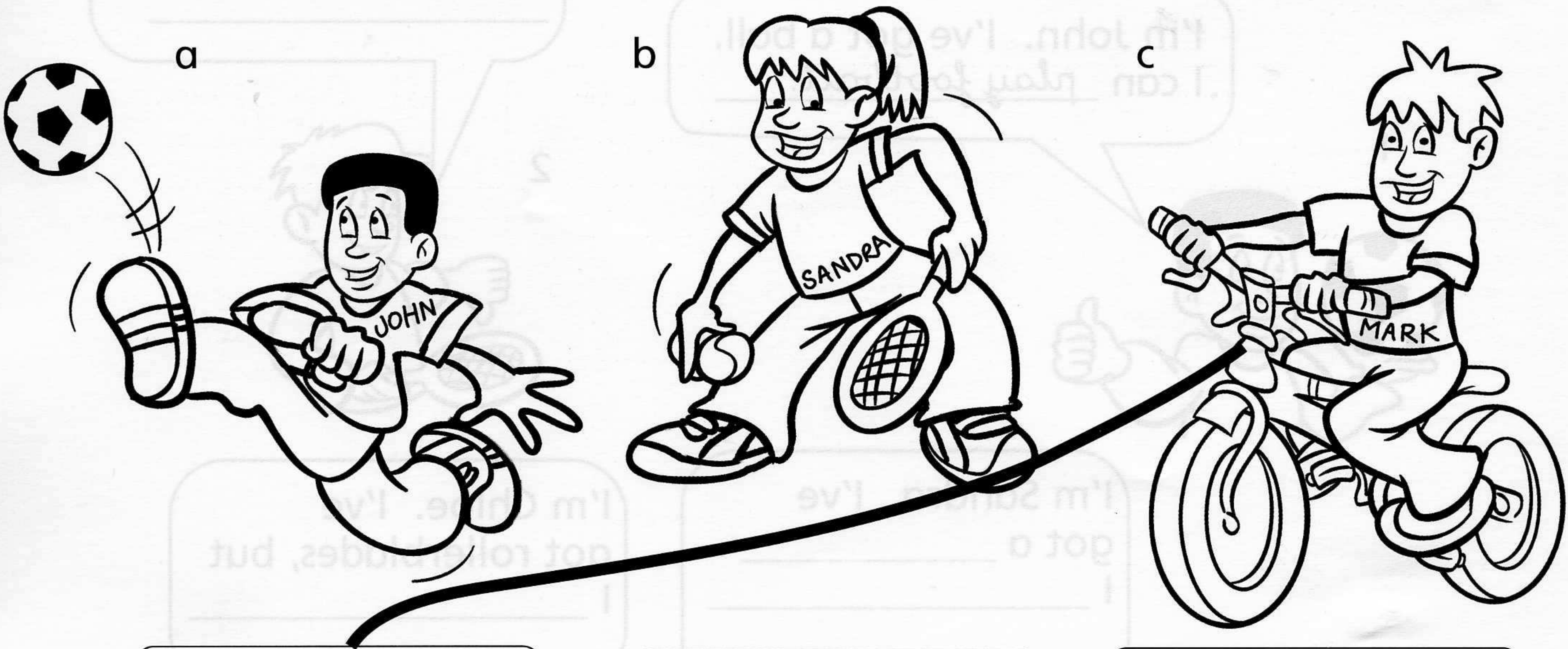

1 Mark's wearing a purple T-shirt, blue jeans and black shoes. He can ride a bike.

2 John's wearing an orange T-shirt, black jeans and white trainers. He can play football.

3 Sandra's wearing a white T-shirt, blue jeans and green trainers. She can play tennis.

Unit 5 Activity 6

Look, read and write true (T) or false (F).

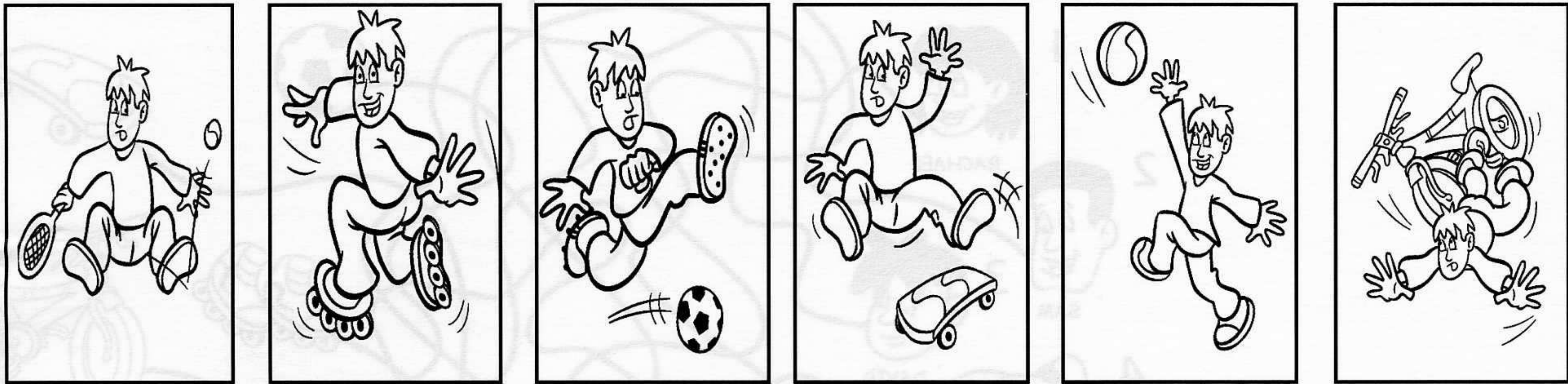

1 I can't play tennis. T

2 I can rollerblade.

3 I can't play football.

4 I can skateboard.

5 I can play basketball.



6 I can't ride a bike.

Unit 5 Activity 7

Look and write.

	play tennis	play football	ride a bike	play basketball	ski	rollerblade
EMILY	✓	X	✓	X	X	✓
ARCHIE	✓	✓	✓	X	✓	X
MIKE	X	✓	X	✓	X	✓

1 Emily can play tennis, but she can't ski.

2 _____

3 _____

4 _____

5 _____

6 _____

Unit 5 Activity 8

Write.

1 Can you rollerblade ?

No, I can't.

2 _____

No, I can't.

3 _____

Yes, I can.

4 _____

Yes, I can.

5 _____

No, I can't.

6 _____

Yes, I can.

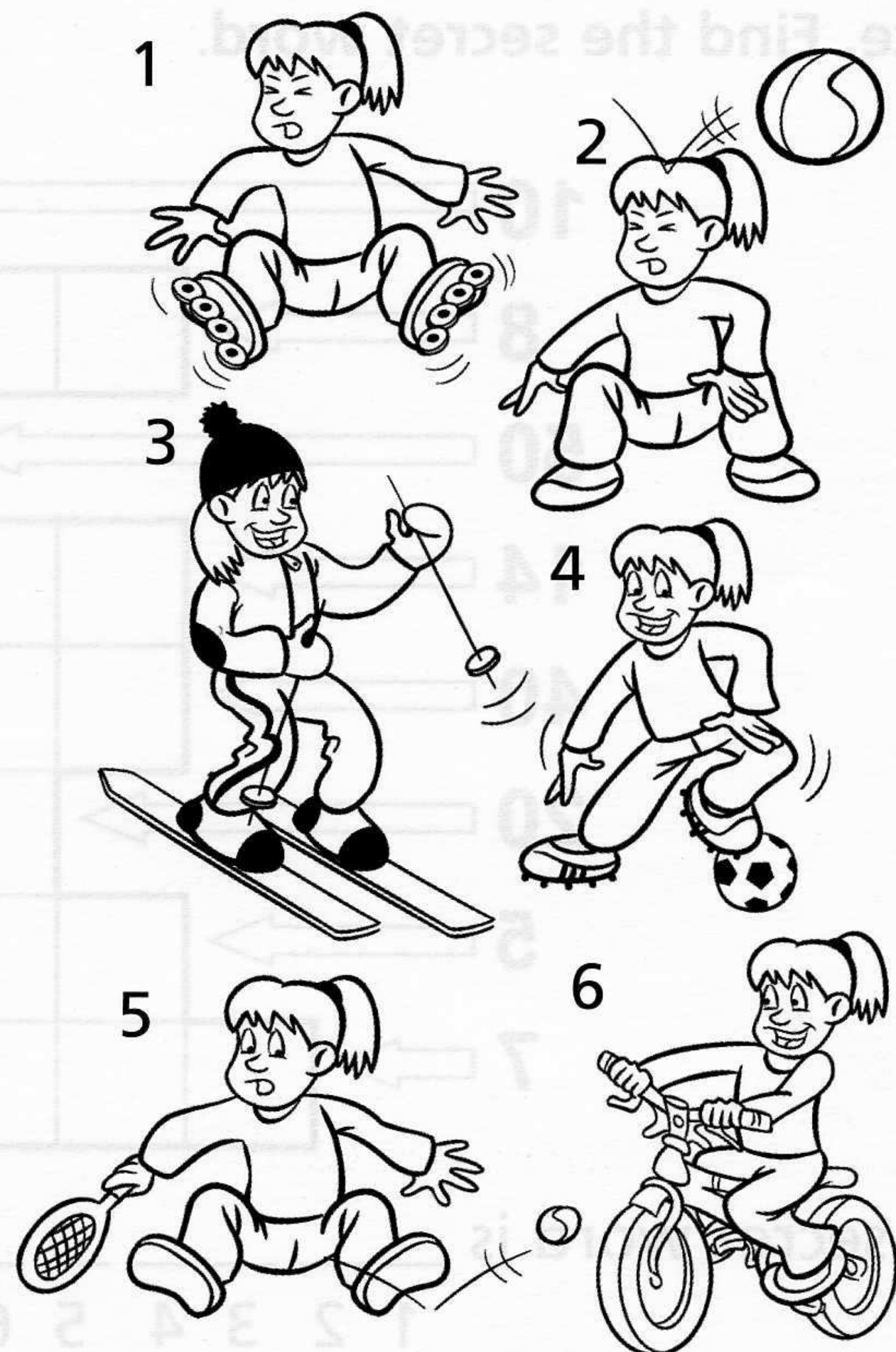

PHOTOCOPIABLE

Unit 6 Activity 11

Order and write.

o'clock up
get I
seven at

1 I get up at seven o'clock.

2

shower I past
half at
a seven have

I half nine
to at
go past bed

3

4

have I half
past at
dinner eight

Unit 6 Activity 12

Read and draw.

1

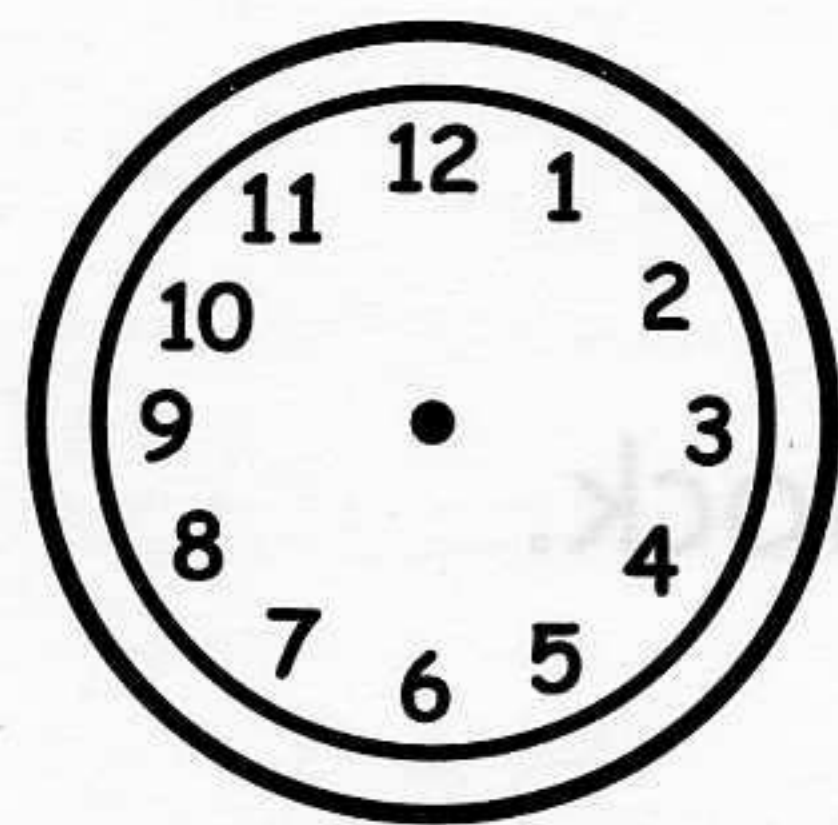

It's ten o'clock.

2

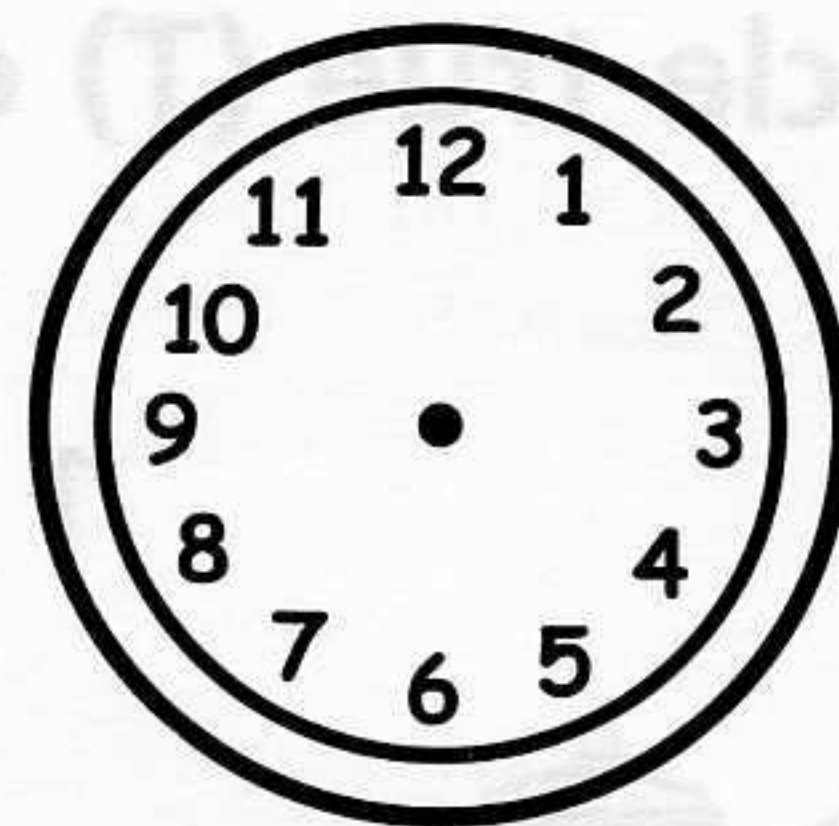

It's six o'clock.

3



It's eleven o'clock.

4



It's half past four.

5

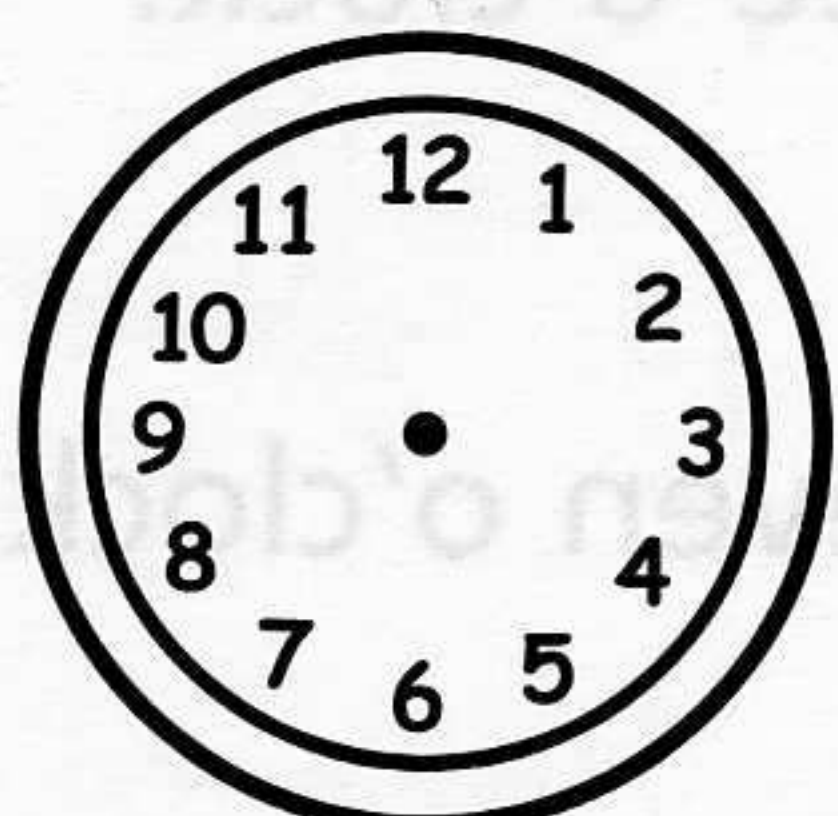

It's half past six.

6



It's half past one.

PHOTOCOPIABLE

Unit 6 Activity 13

Write.

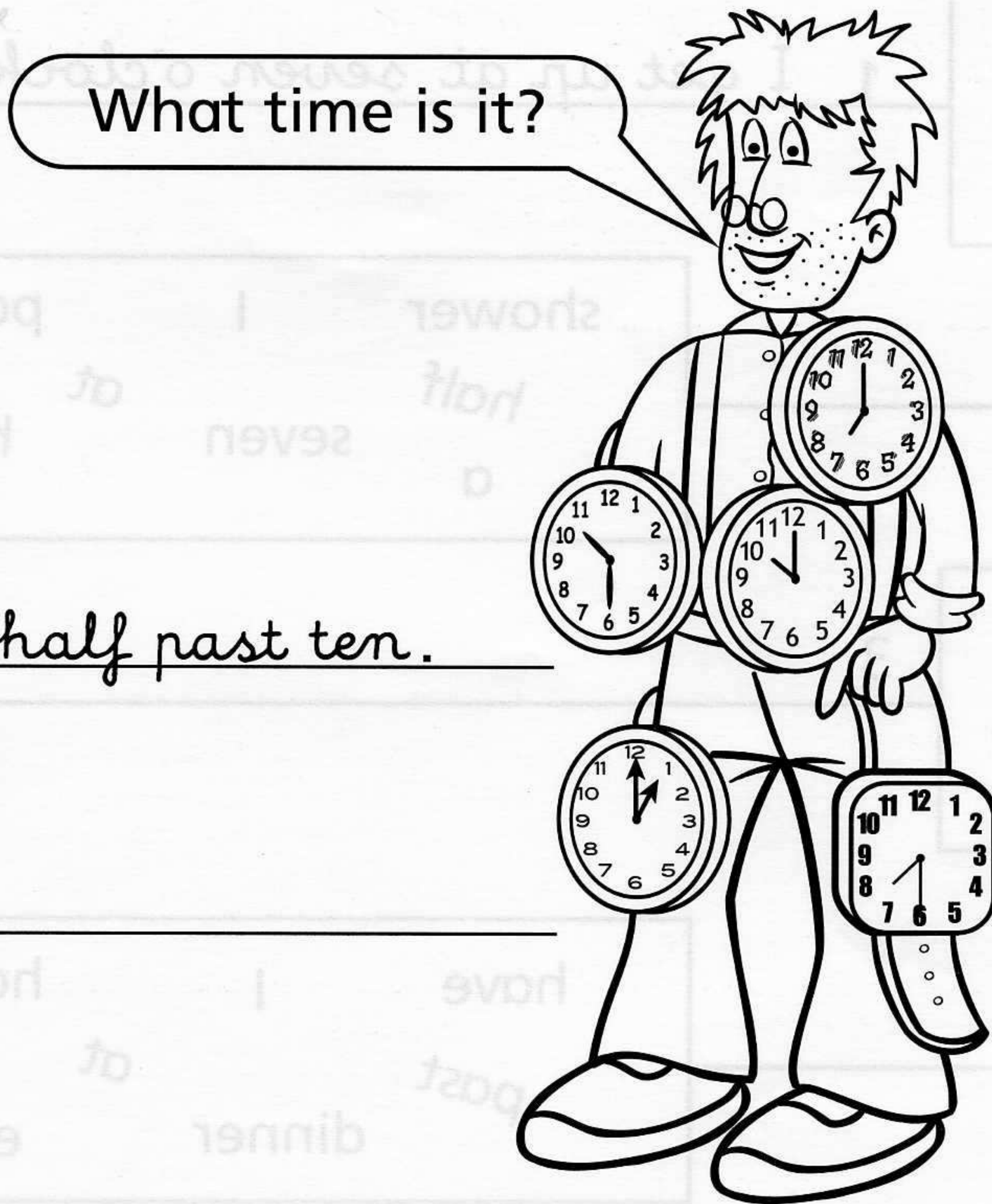

1 It's half past ten.

4 _____

2 _____

3 _____

5 _____

Unit 6 Activity 14

Read, look and circle true (T) or false (F).

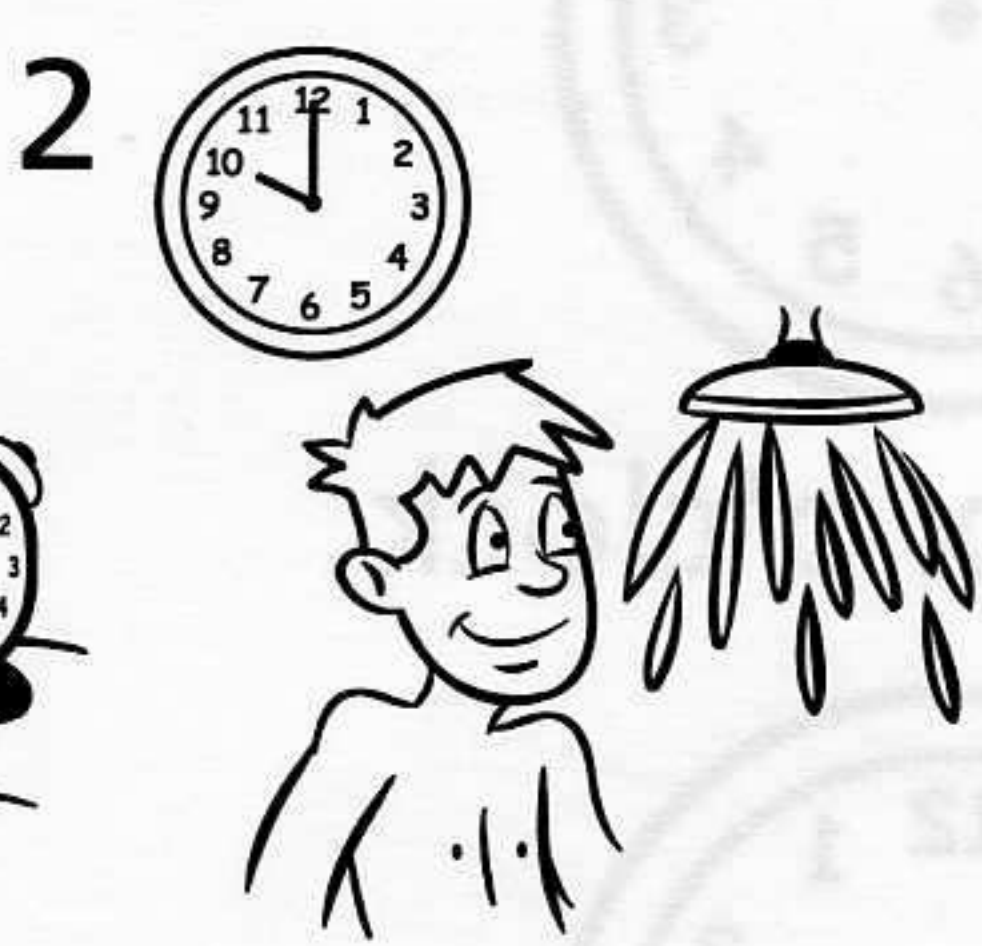

1 I get up at nine o'clock. T F

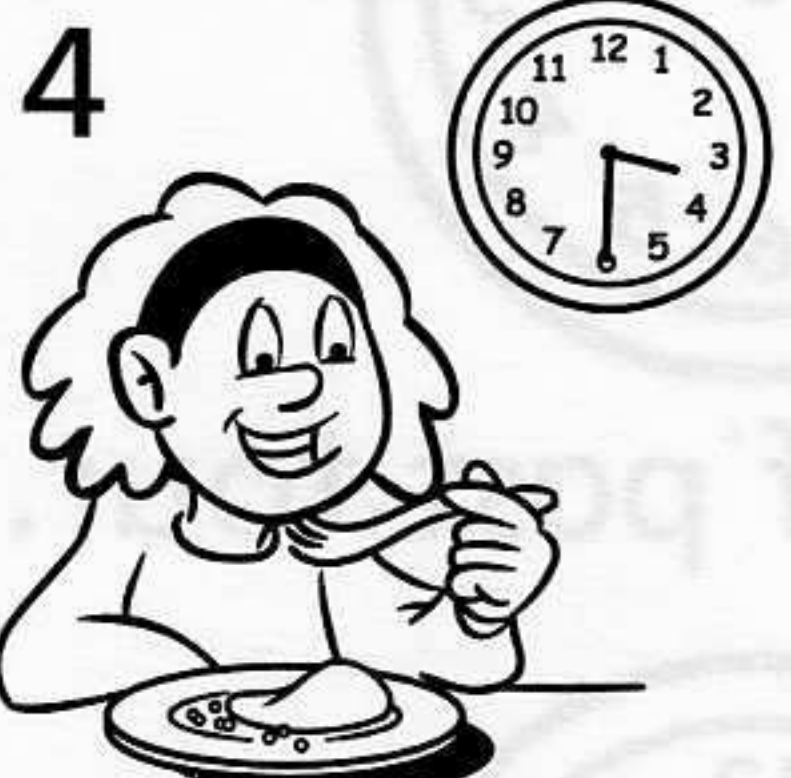

2 I have a shower at ten o'clock. T F

3 I have breakfast at half past nine. T F

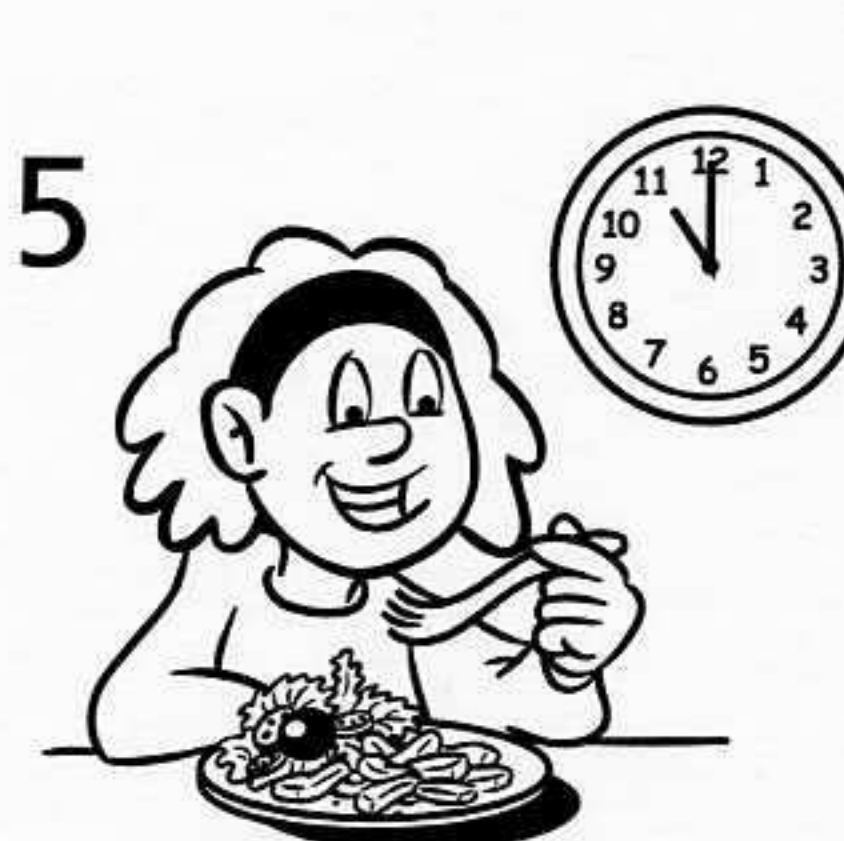

4 I have lunch at three o'clock. T F

5 I have dinner at eleven o'clock. T F

6 I go to school at nine o'clock. T F

Unit 6 Activity 15

Write.

1



2



3



4

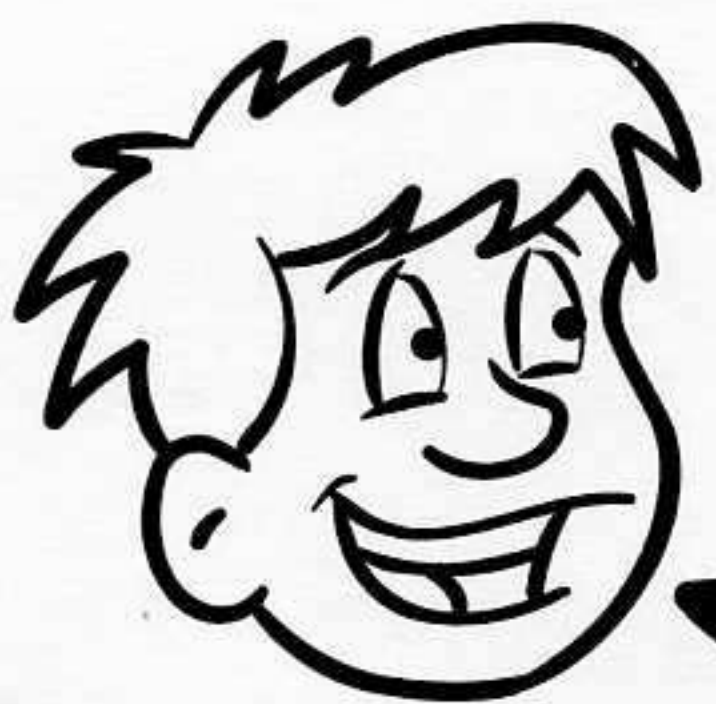

I have breakfast at eight o'clock.

I have lunch at _____

I have dinner at _____

I go to bed at _____

Unit 6 Activity 16

Find and write.

1

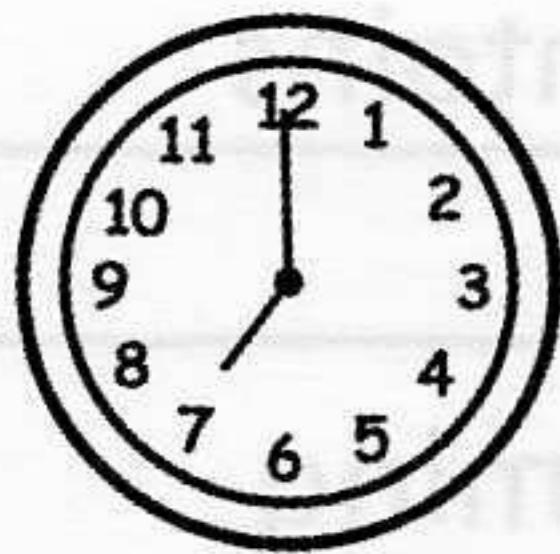

I have breakfast at
seven o'clock.

2

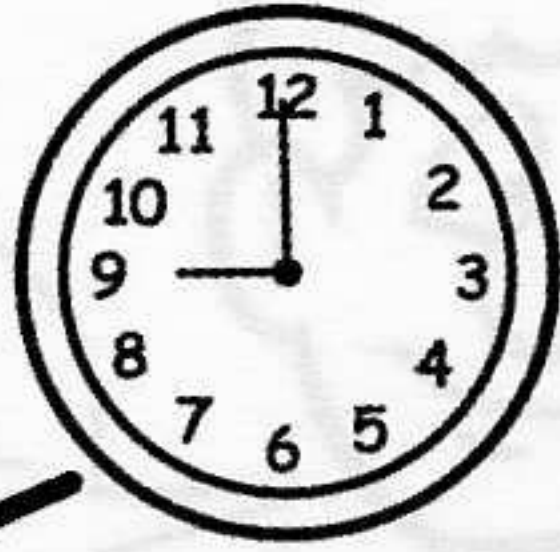

3

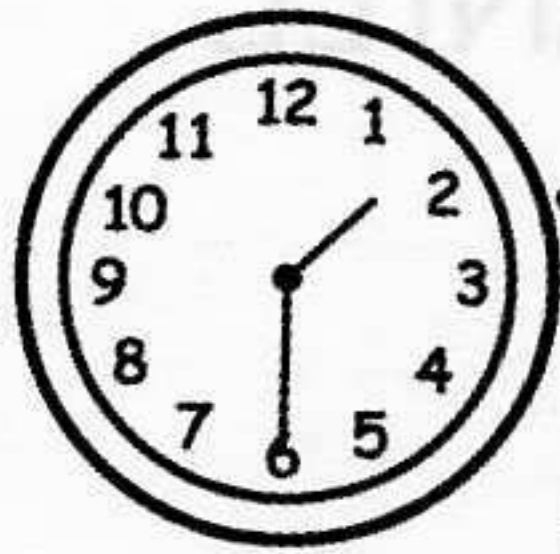

4

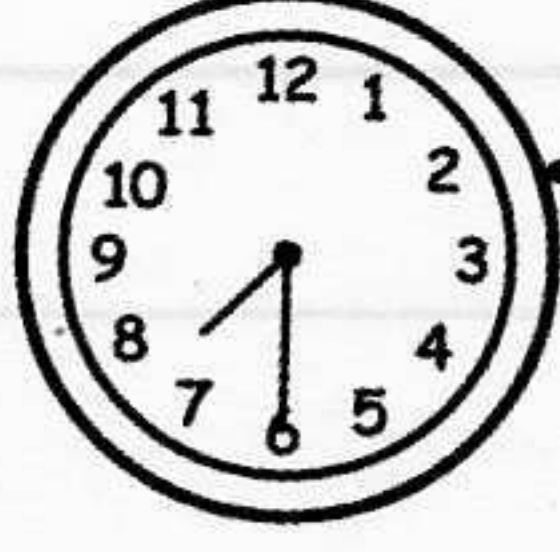

PHOTOCOPIABLE

Unit 6 Activity 1

Read and number.

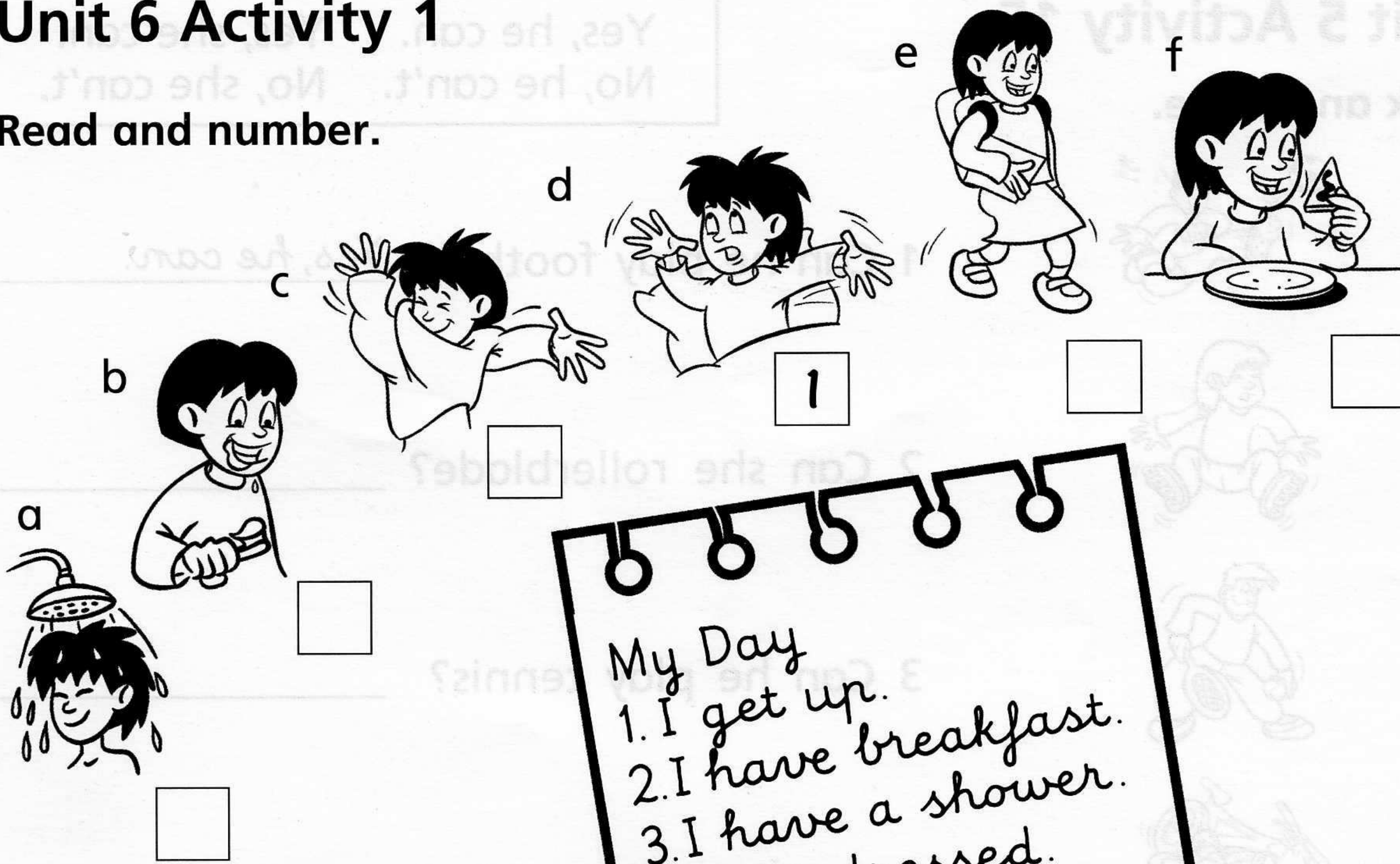

My Day
 1. I get up.
 2. I have breakfast.
 3. I have a shower.
 4. I get dressed.
 5. I brush my teeth.
 6. I go to school.
 Julie

Unit 6 Activity 2

Read and number.

MY DAY

~~I get up.~~ I have breakfast.
 I have a shower. I get dressed.
 I brush my teeth. I go to school.

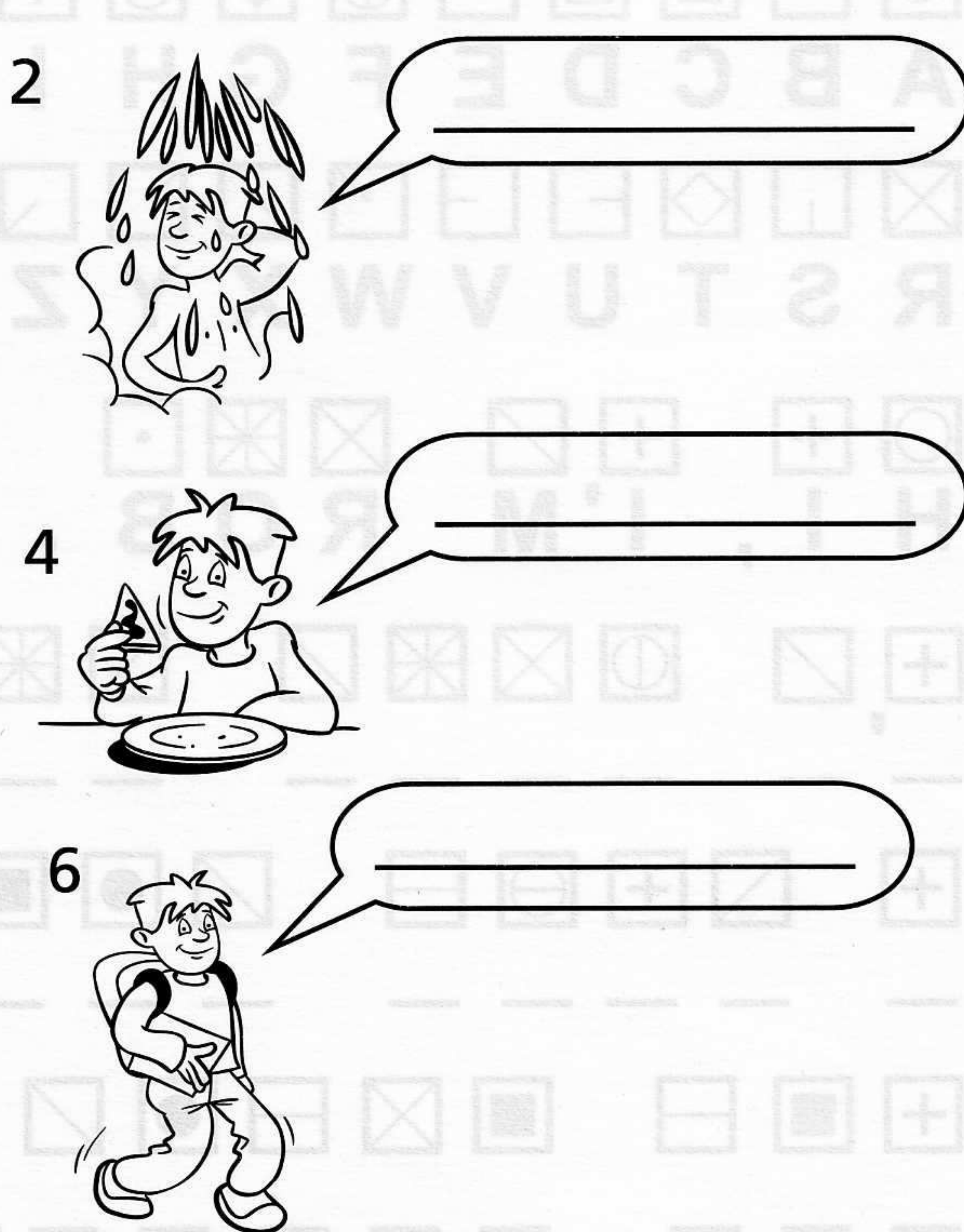
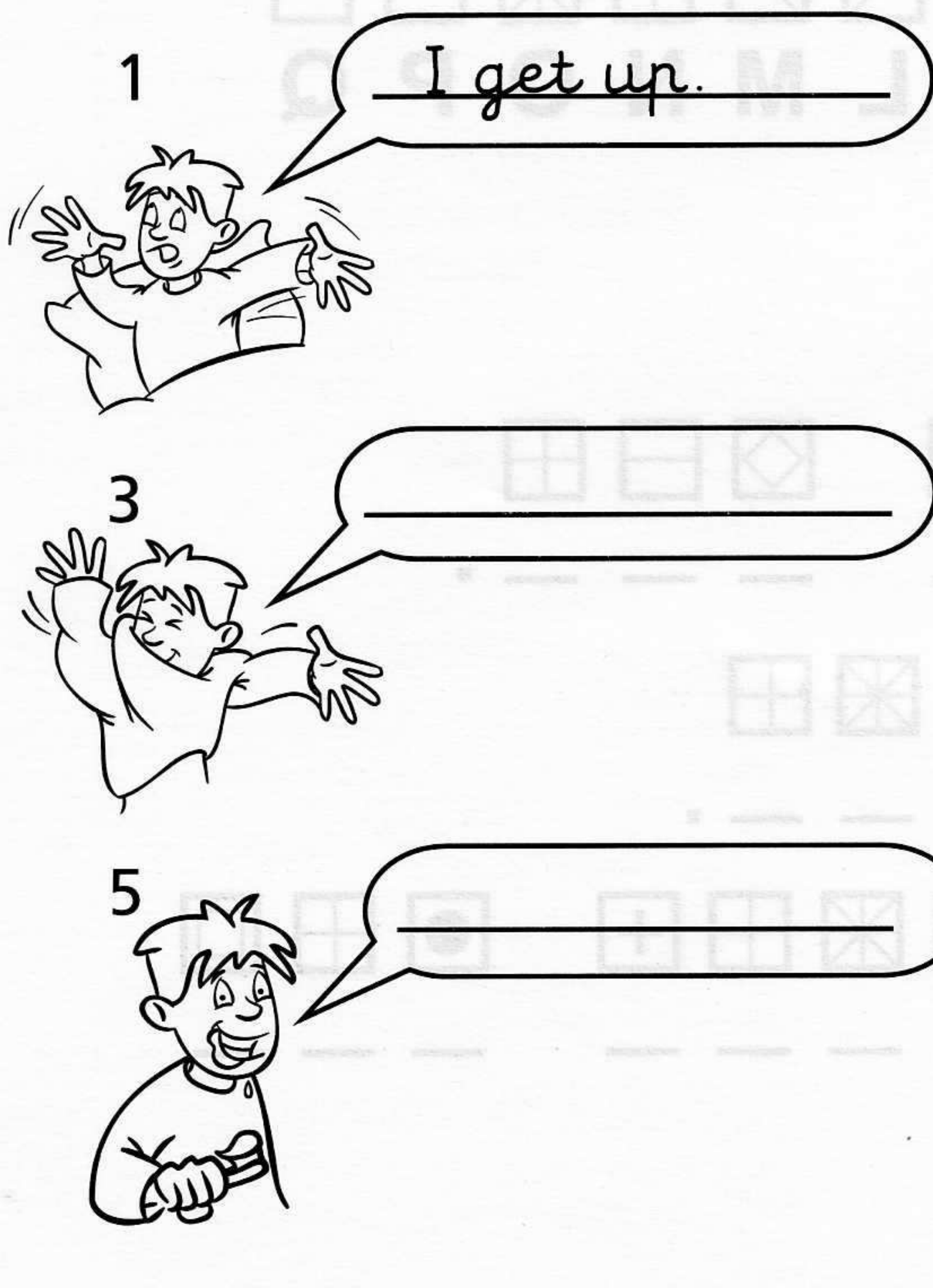

Unit 6 Activity 3

Order, write and match. Read and match.

1 get up I

I get up.

2 school to go I

3 have I breakfast

4 I dressed get

5 brush I teeth my

6 shower have a I

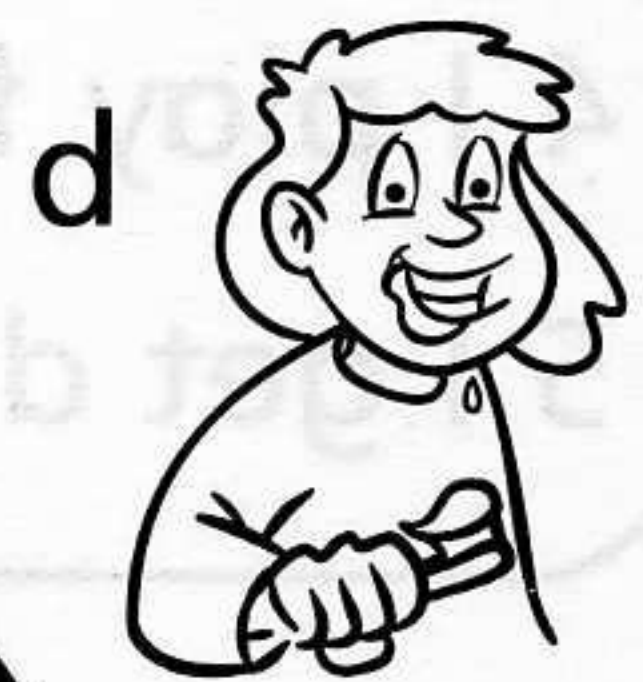

Unit 6 Activity 4

Write about your day.

MY DAY

1 _____

2 _____

3 _____

4 _____

5 _____

6 _____

PHOTOCOPIABLE

Unit 6 Activity 5

Read, look and write true (T) or false (F).

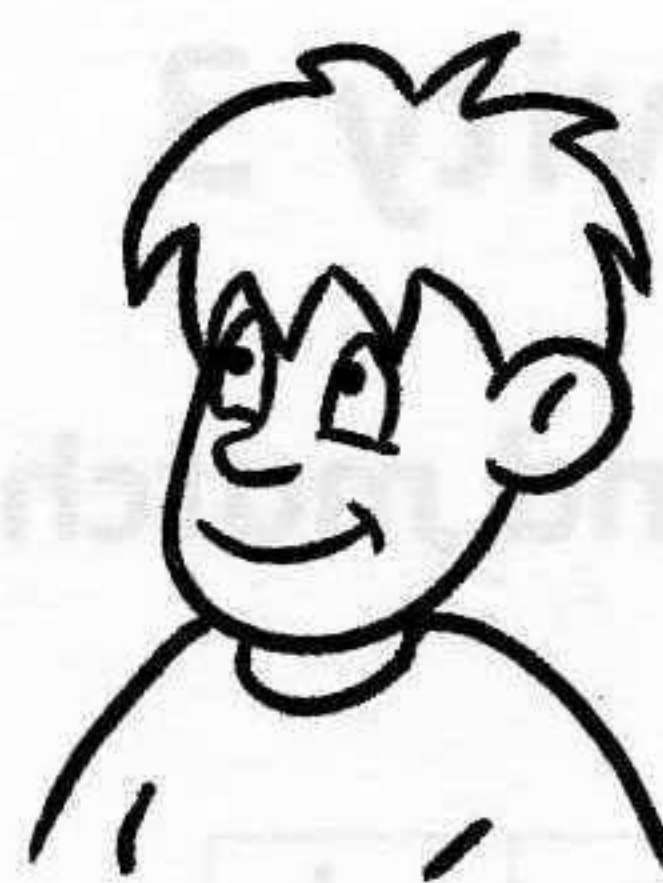

- 1 I brush my teeth in the morning.
- 2 I play tennis in the afternoon.
- 3 I go to school in the morning.
- 4 I play football in the morning.
- 5 I get dressed in the afternoon.

F

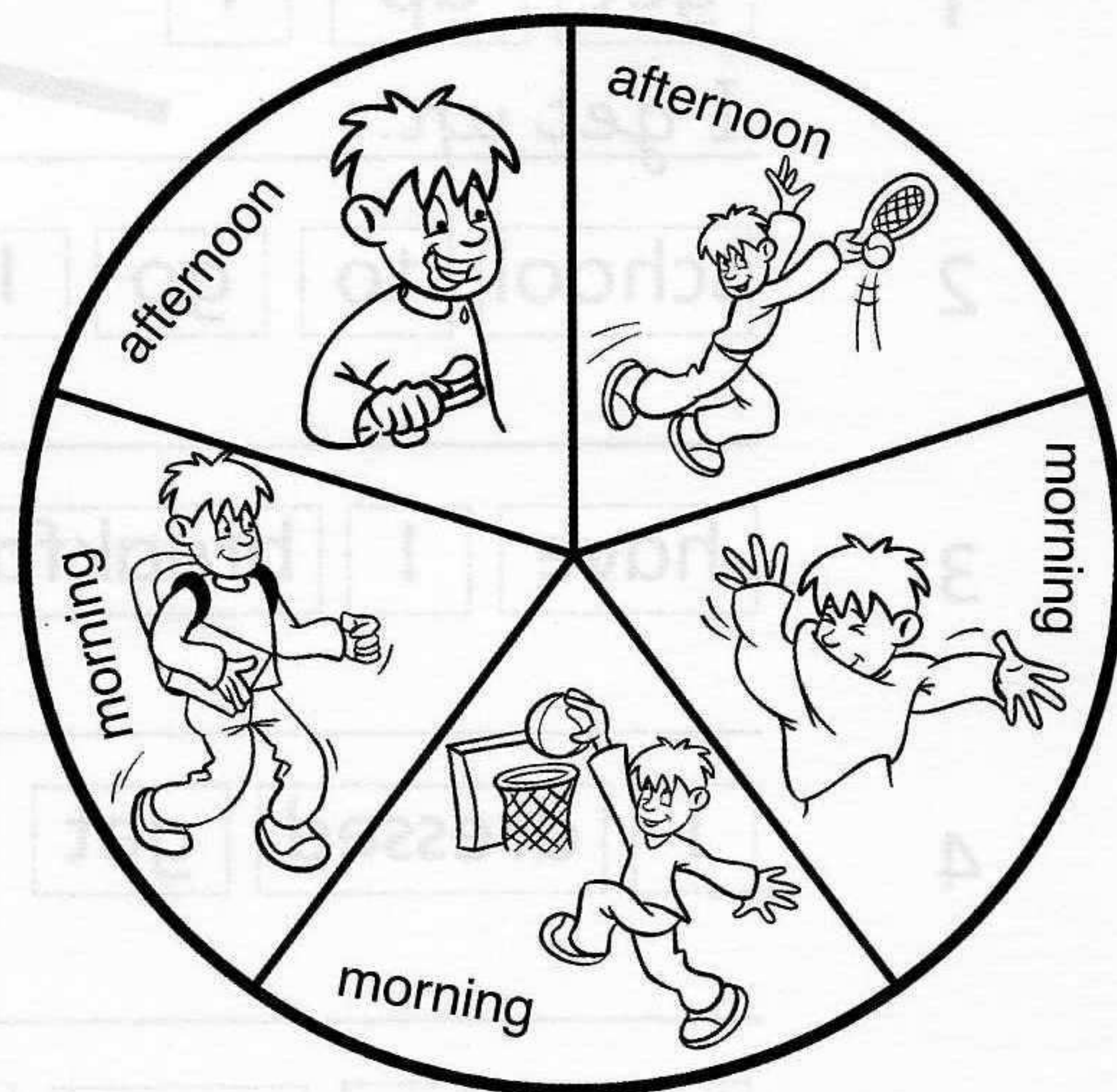

Unit 6 Activity 6

Write.

1 ANN

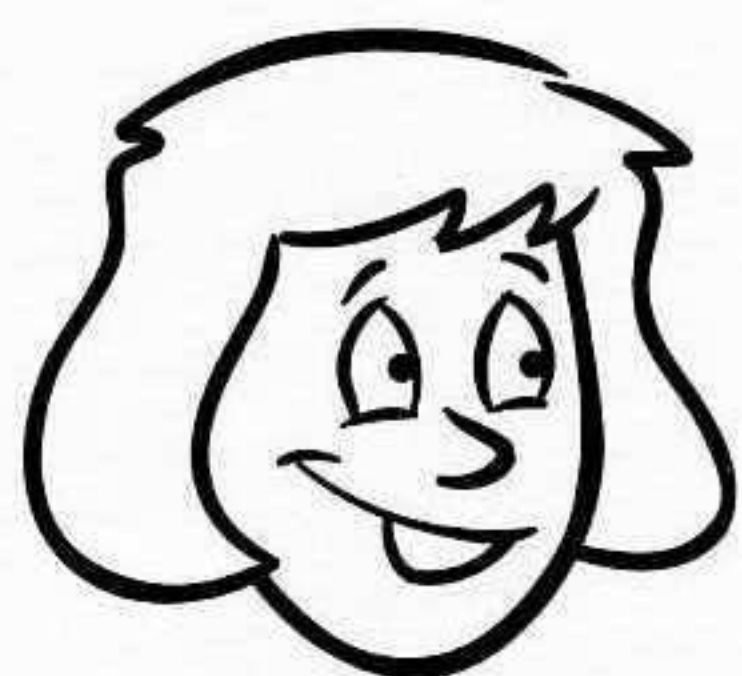

YES



Ann can ride a bike.

2 JOE



NO

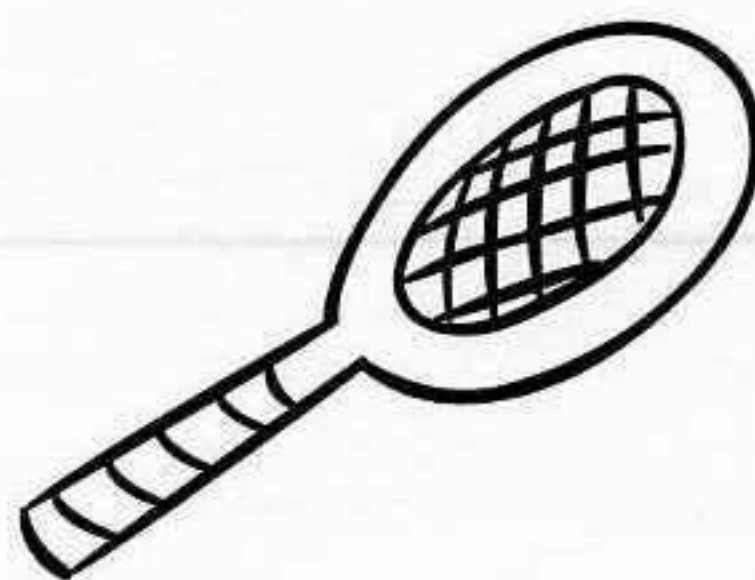

Joe can't play tennis.

3 TIM



YES



4 MARIA

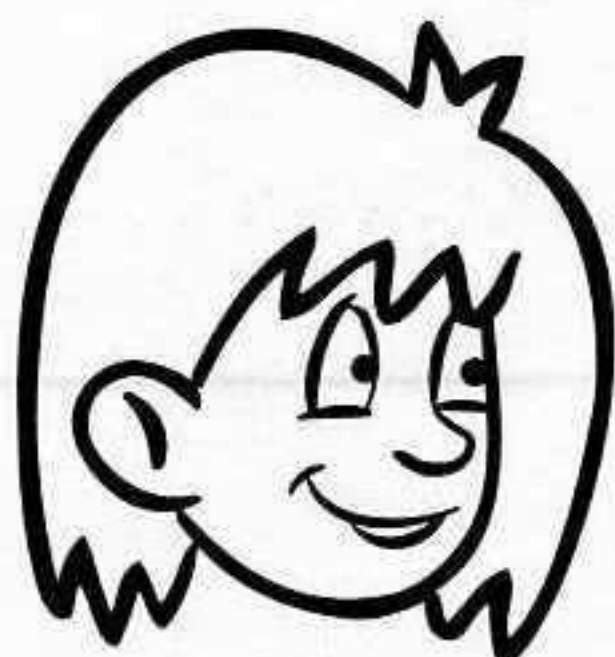

YES



5 MIKE



NO



Unit 6 Activity 7

Write.

1 twenty-eight

I can rollerblade.



2 twenty



3 forty-seven



4 fifteen



5 thirty-three



6 seven



Unit 6 Activity 8

Write. Find the secret word.

The secret word is _____
 1 2 3 4 5 6 7

PHOTOCOPIABLE

Unit 6 Activity 9

Read and number.

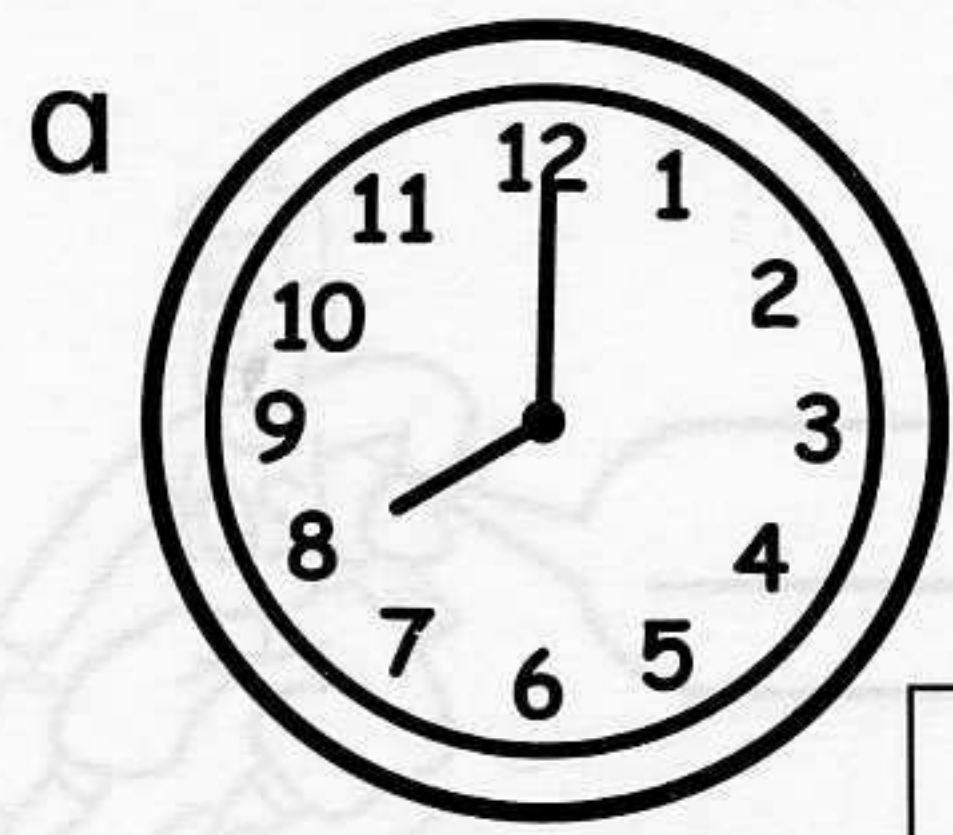

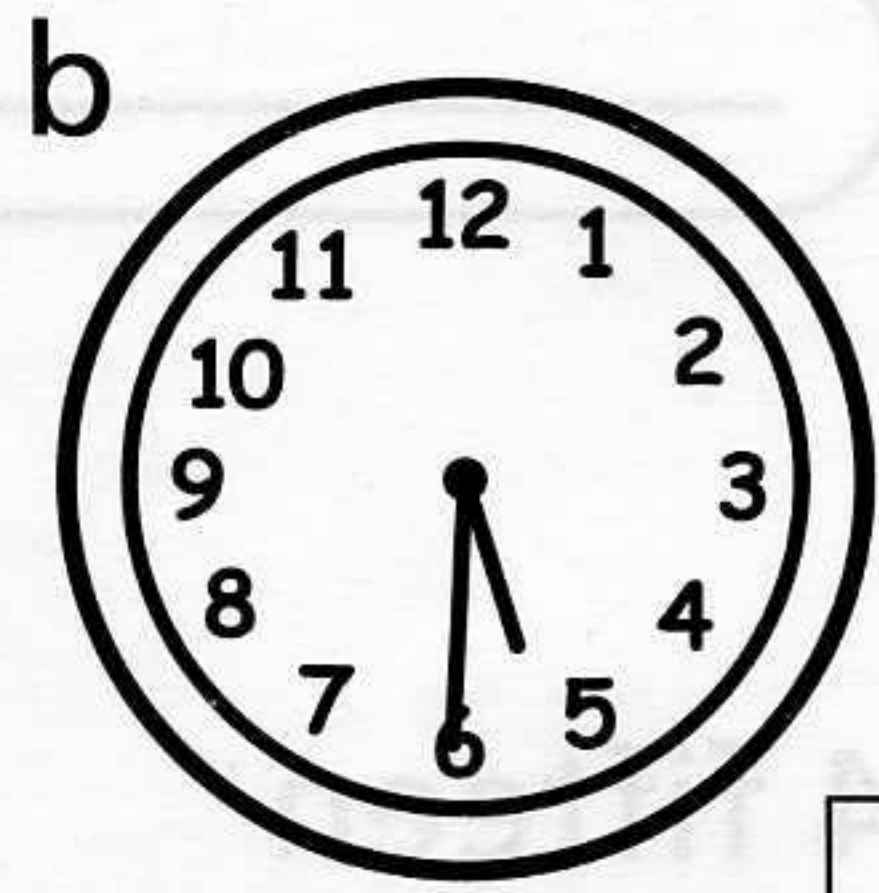

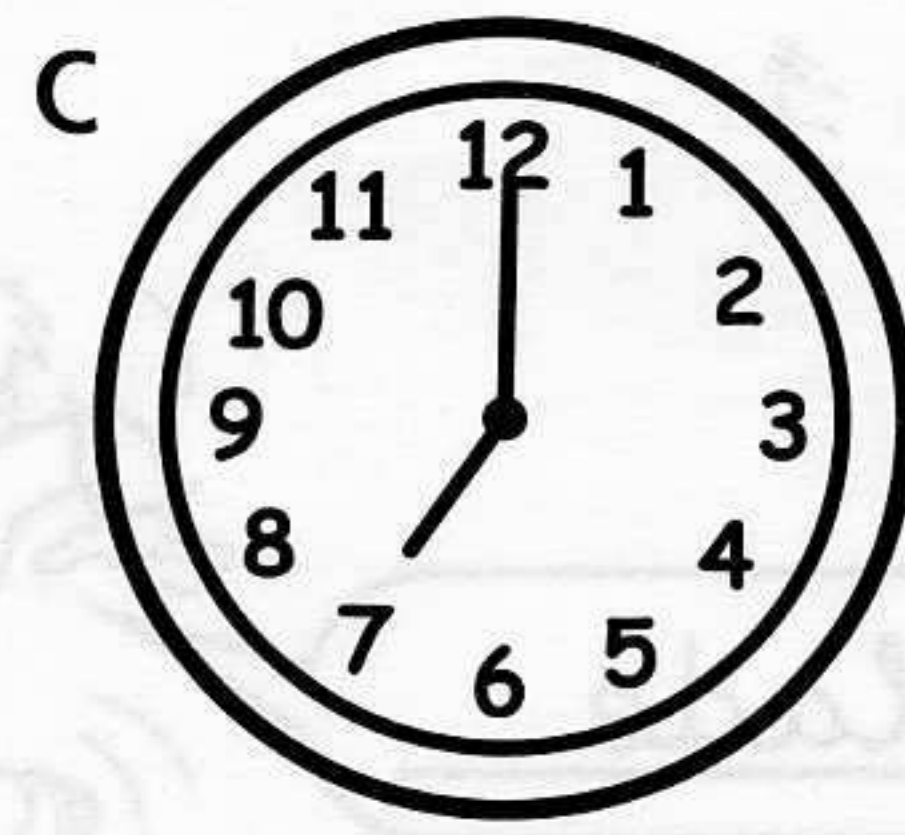

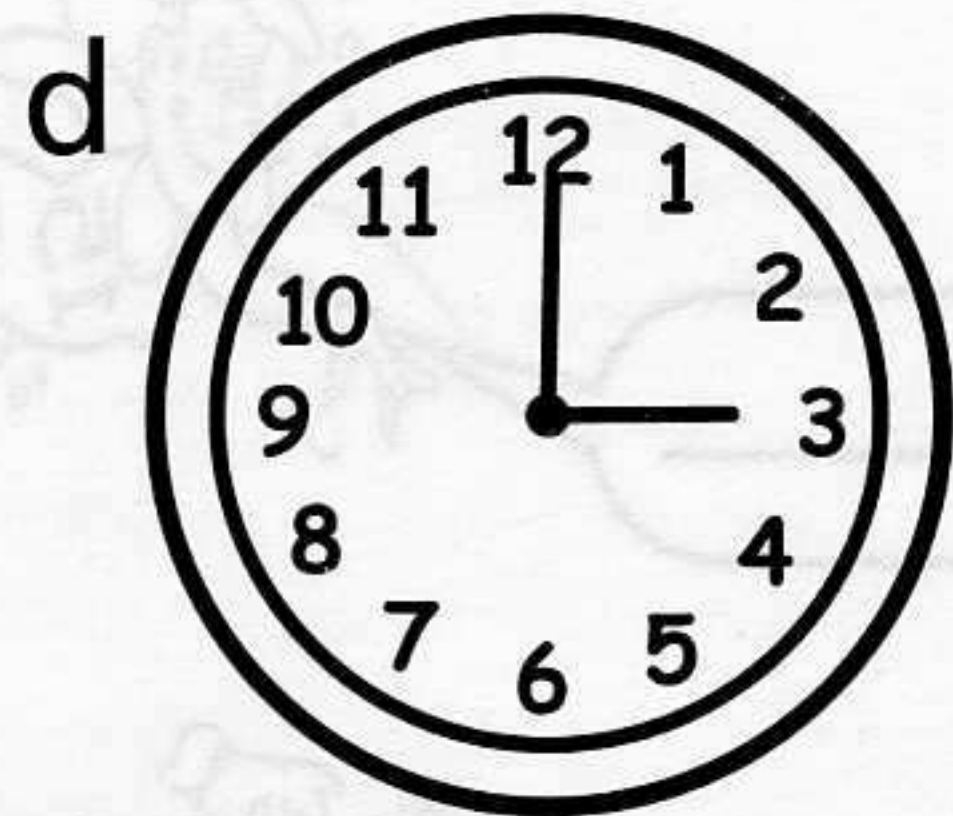

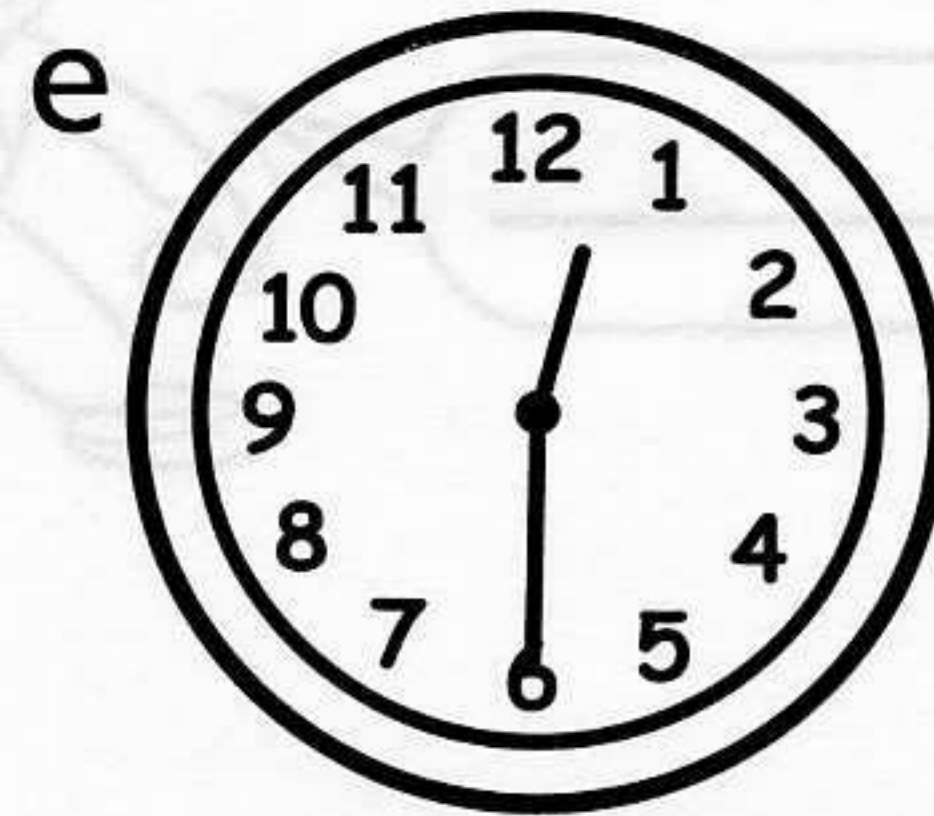

1 It's half past five.

2 It's half past twelve.

3 It's eight o'clock.

4 It's three o'clock.

5 It's seven o'clock.

Unit 6 Activity 10

Read and write.

~~pink~~ rollerblade blue play football forty
~~play tennis~~ ~~thirty~~ fourteen orange skateboard
 fifty play basketball green twenty-five yellow

1 SPORTS

play tennis

2 NUMBERS

thirty

3 COLOURS

pink

Unit 7 Activity 1

Write.

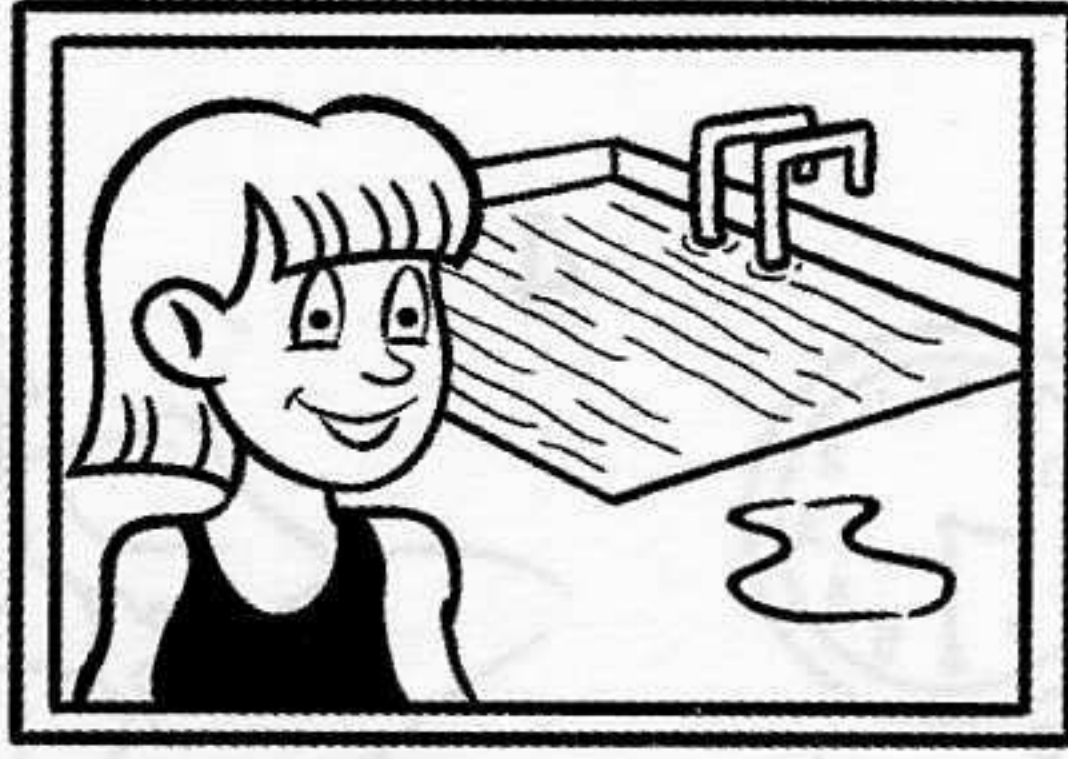

1 swimming pool



2 _____



3 _____

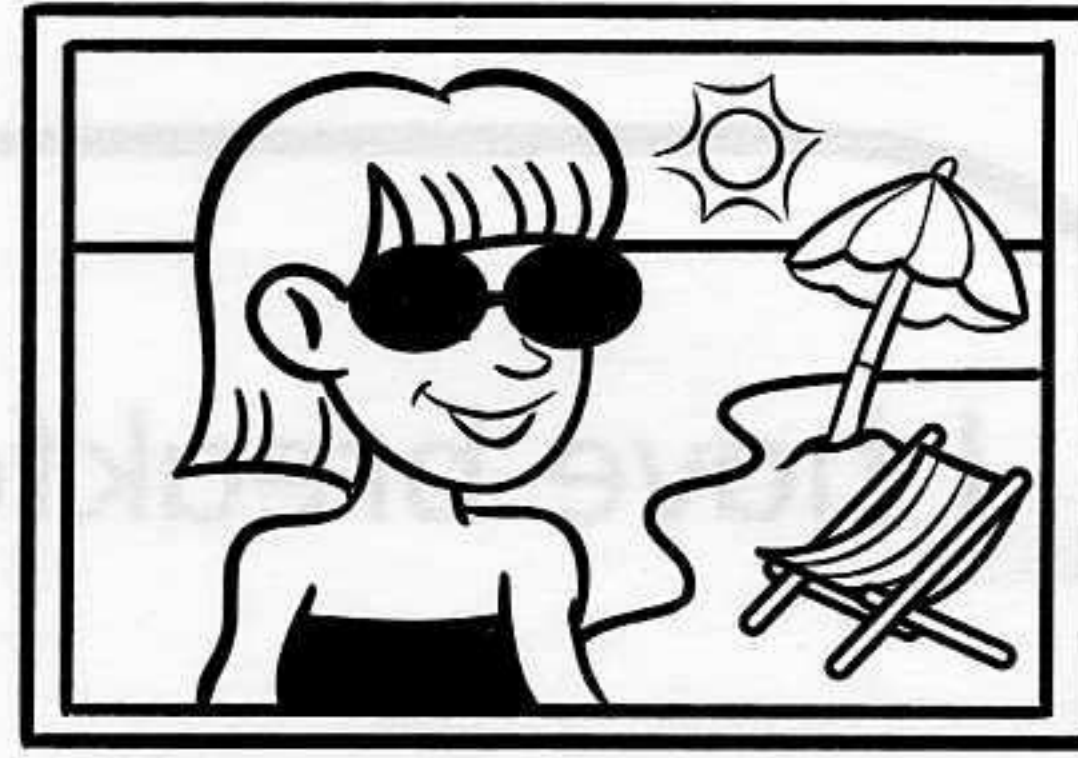

4 _____



5 _____



6 _____

Unit 7 Activity 2

Read and write.

Annie	beach
Ben	mountains
Sally	lake
Daniel	swimming

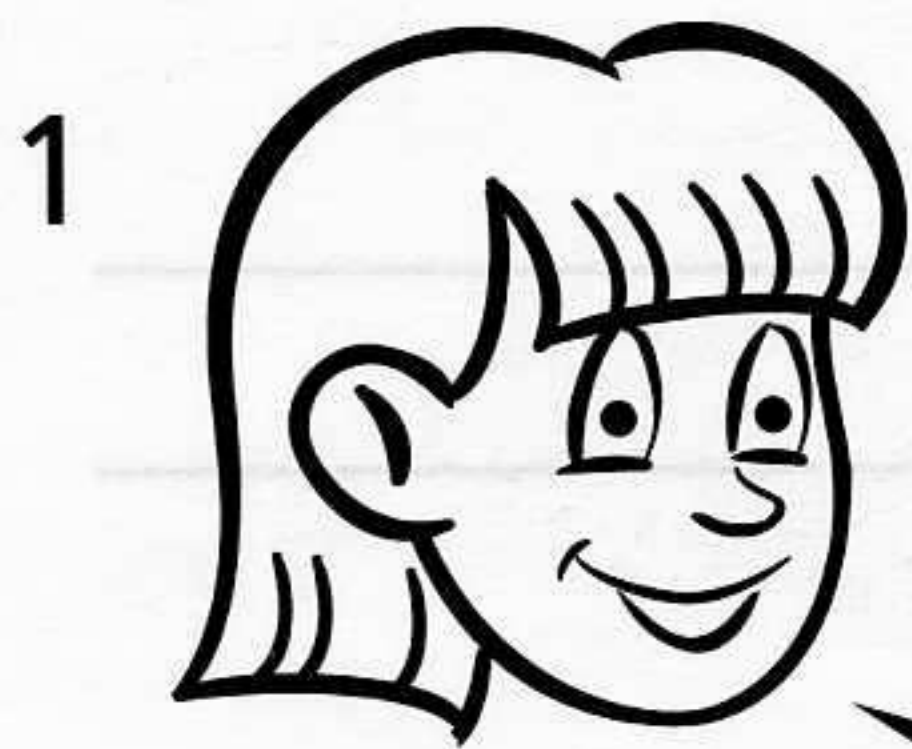

ANNIE

I go to the beach in
the summer.



DANIEL

I _____

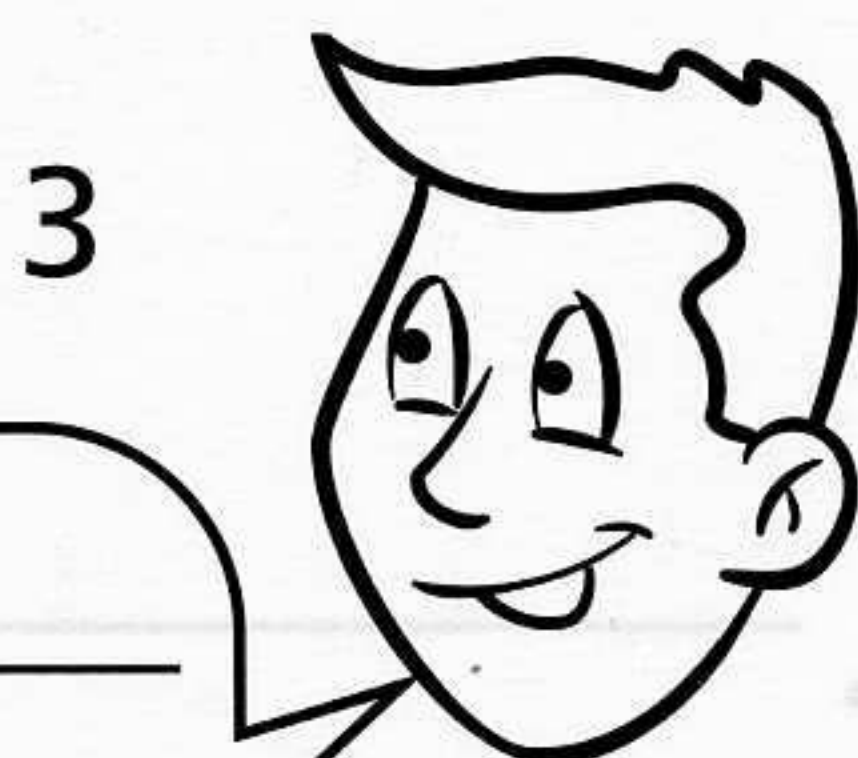

BEN

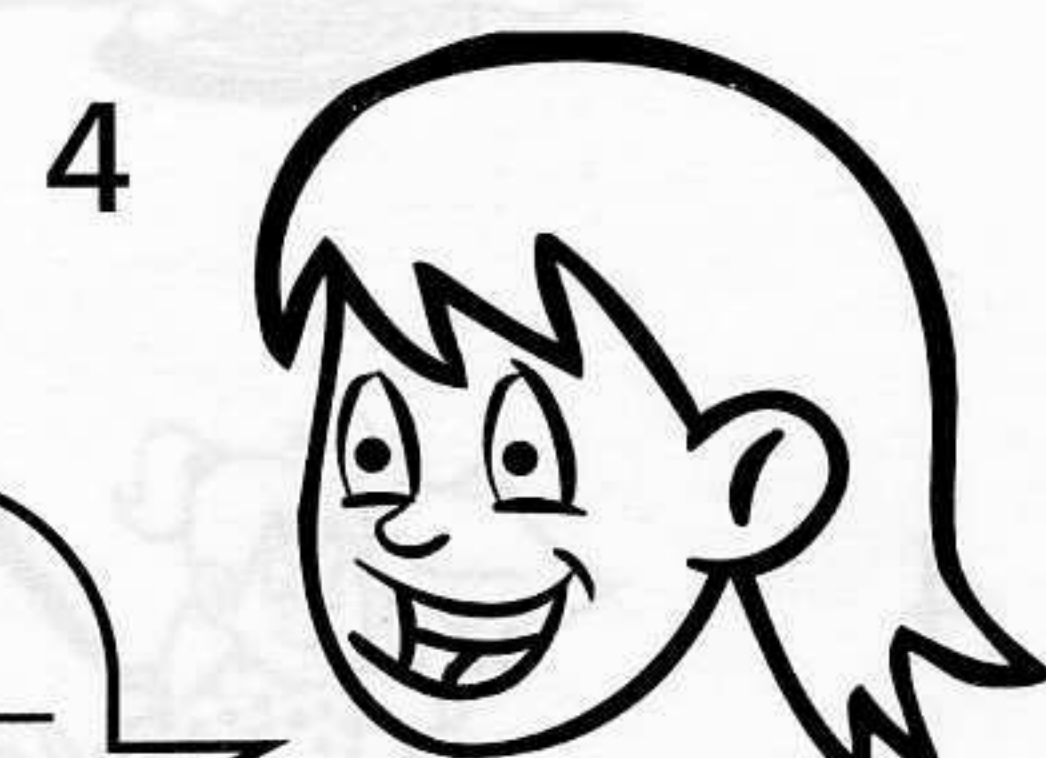

SALLY

Unit 7 Activity 3

Read, count and write.

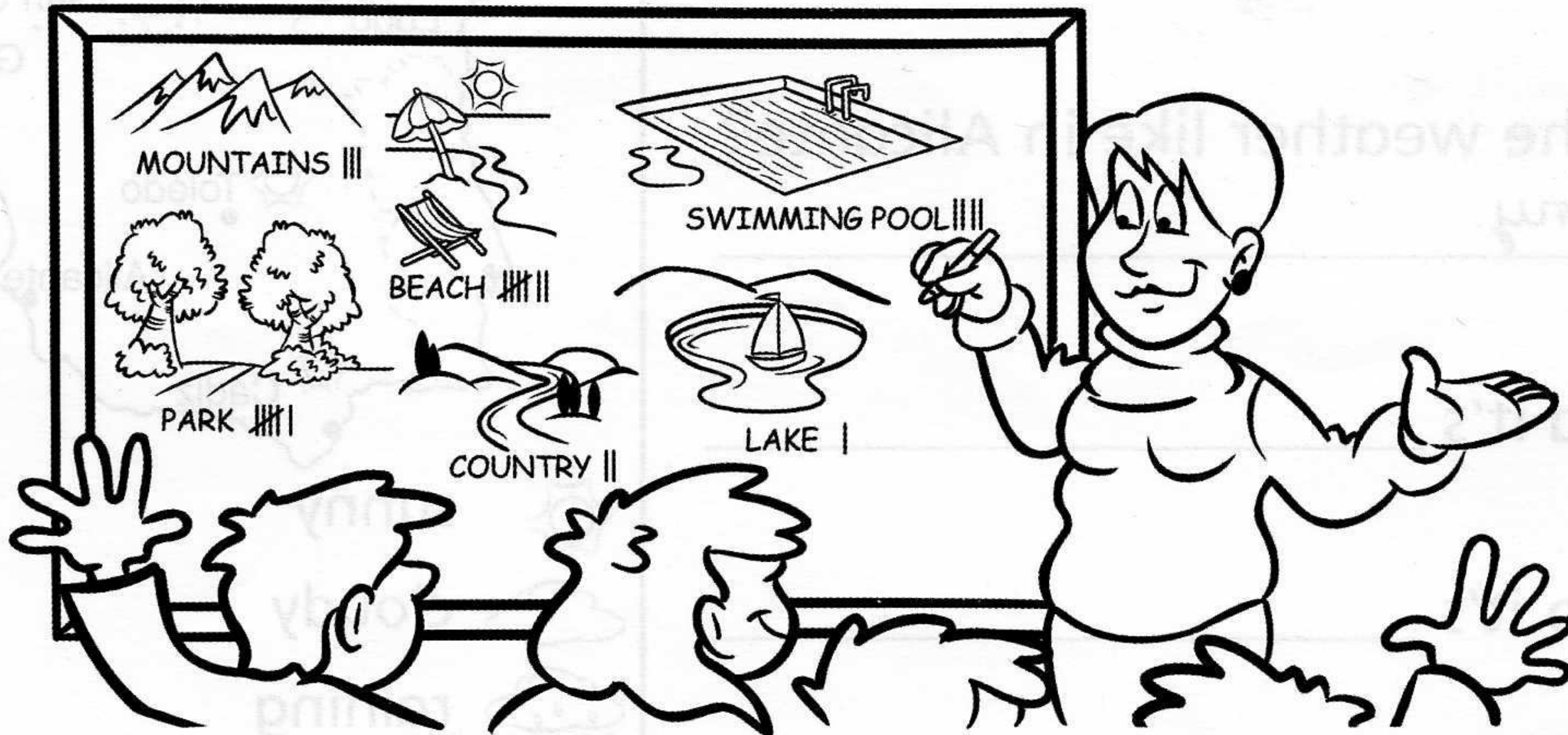

- 1 How many children go to the country in the summer? two
- 2 How many go to the park in the summer? _____
- 3 How many go to the beach in the summer? _____
- 4 How many go to the mountains in the summer? _____
- 5 How many go to the lake in the summer? _____

Unit 7 Activity 4

Match.

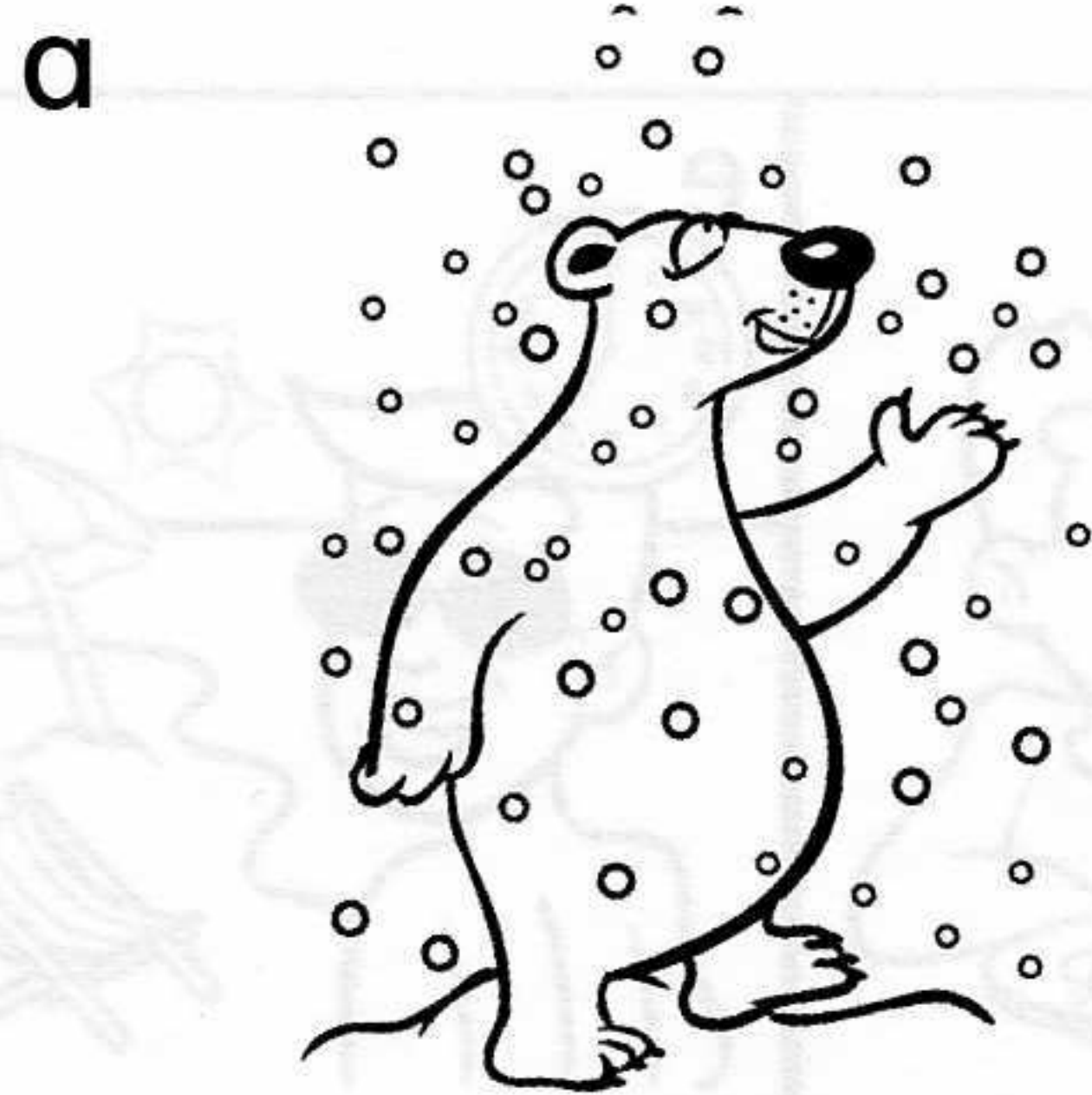

1 It's raining.

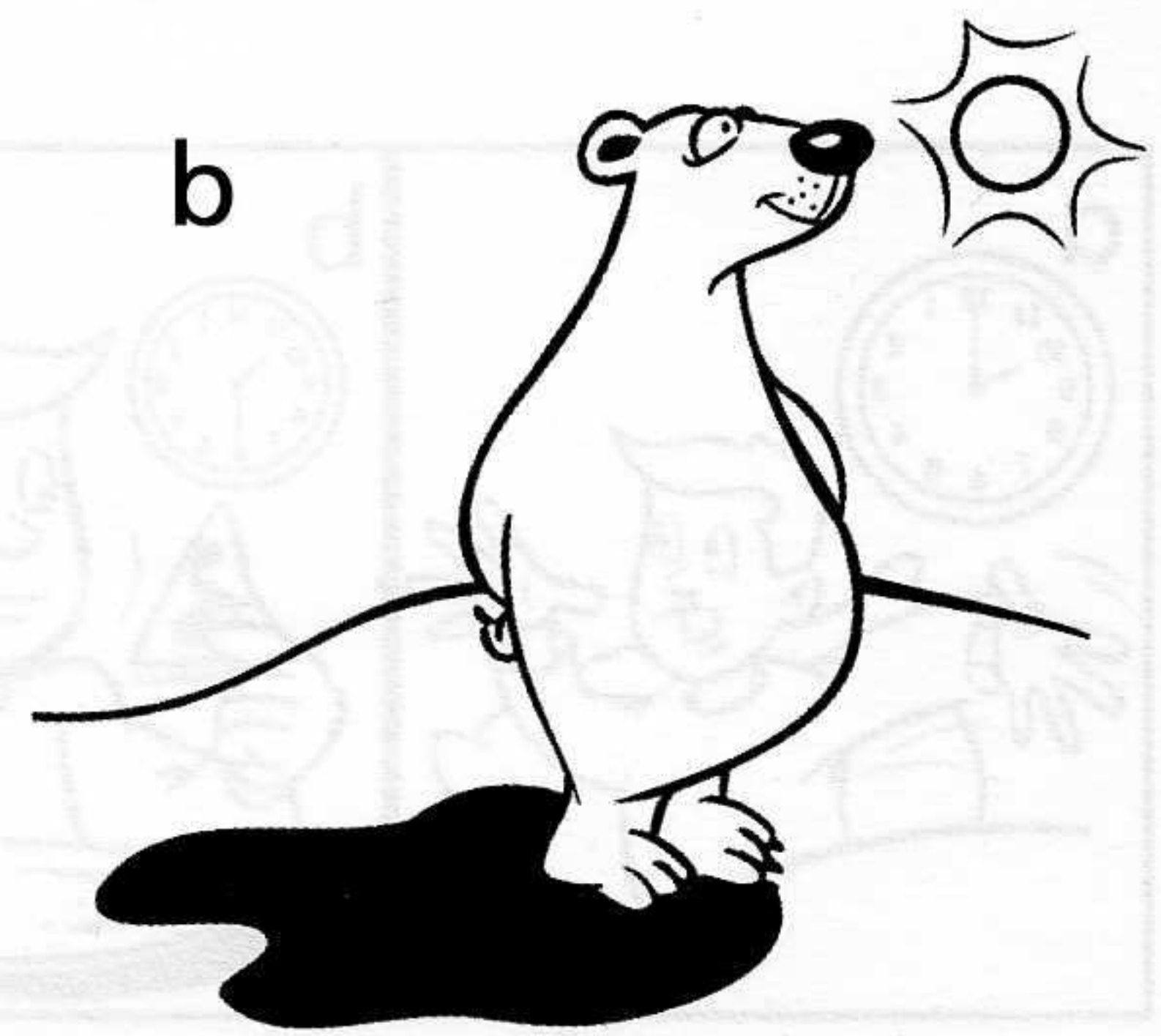

2 It's sunny.

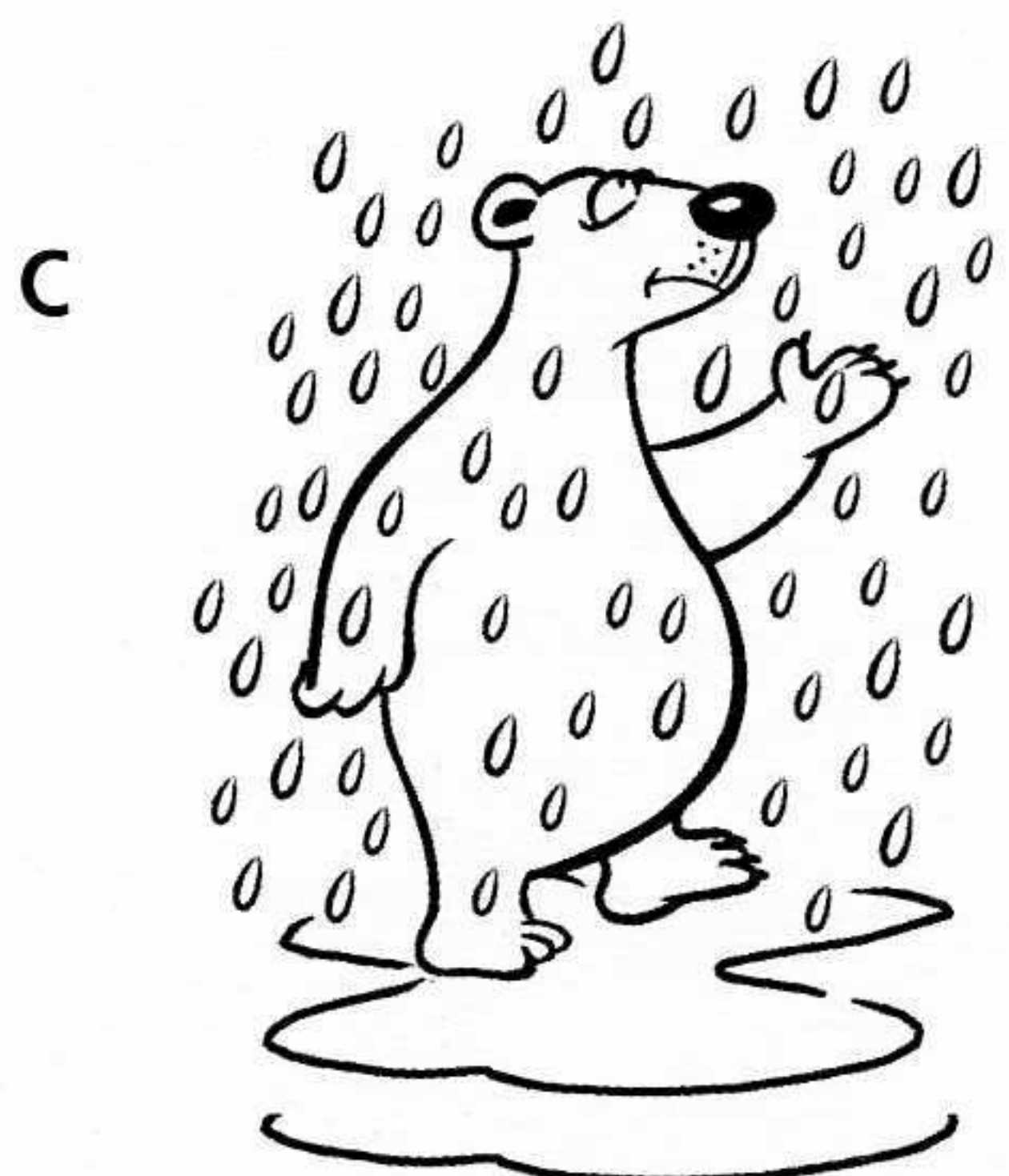

3 It's snowing.



4 It's cloudy.

PHOTOCOPIABLE

Unit 7 Activity 5

Look and write.

1 What's the weather like in Alicante?
It's sunny.

2 In Girona it's _____

3 In Toledo it's _____

4 In Cádiz it's _____

5 In San Sebastián it's _____

6 In Lugo it's _____

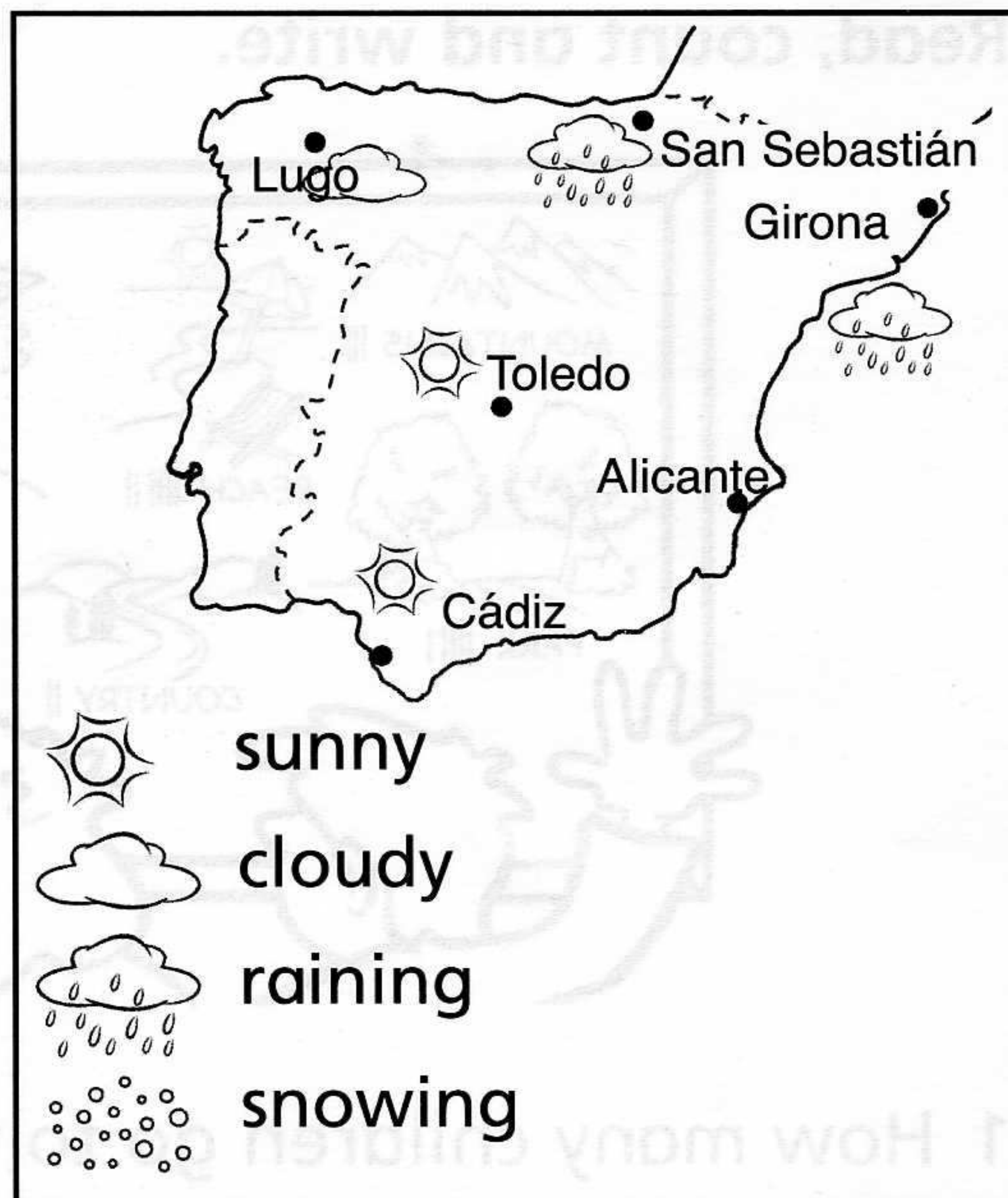

Unit 7 Activity 6

Read and match.

MY HOLIDAY

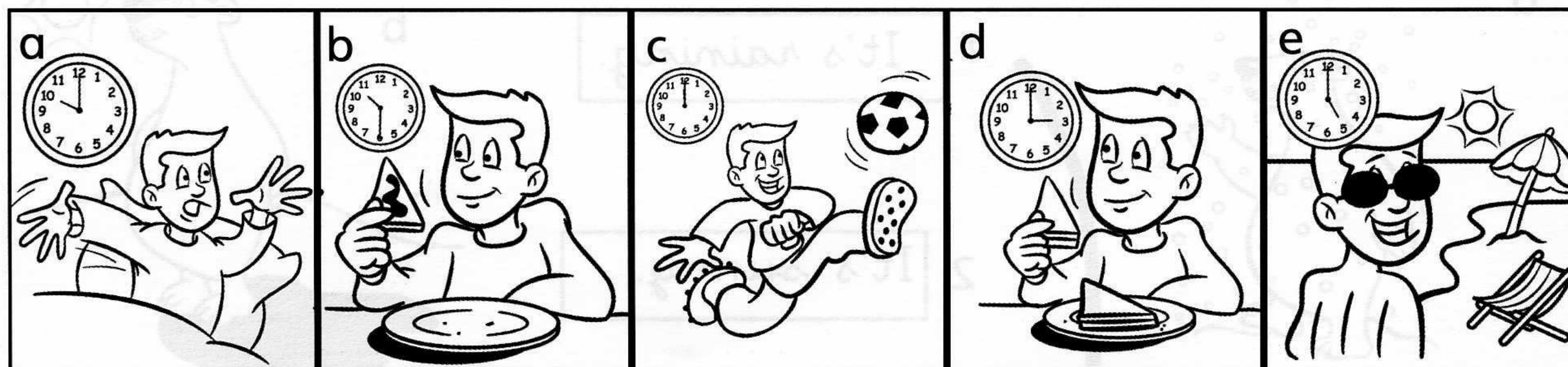

- 1 I go to the beach at five o'clock. e
- 2 I have breakfast at half past ten.
- 3 I have lunch at three o'clock.
- 4 I get up at ten o'clock.
- 5 I play football at twelve o'clock.

Unit 7 Activity 7

Read and draw.

1 Dear Spike,
It's cold and it's raining. I'm on holiday in the mountains.
Love,
Gracie



2 Dear Spike,
It's hot and it's sunny. I'm on holiday on the beach.
Love,
Gracie

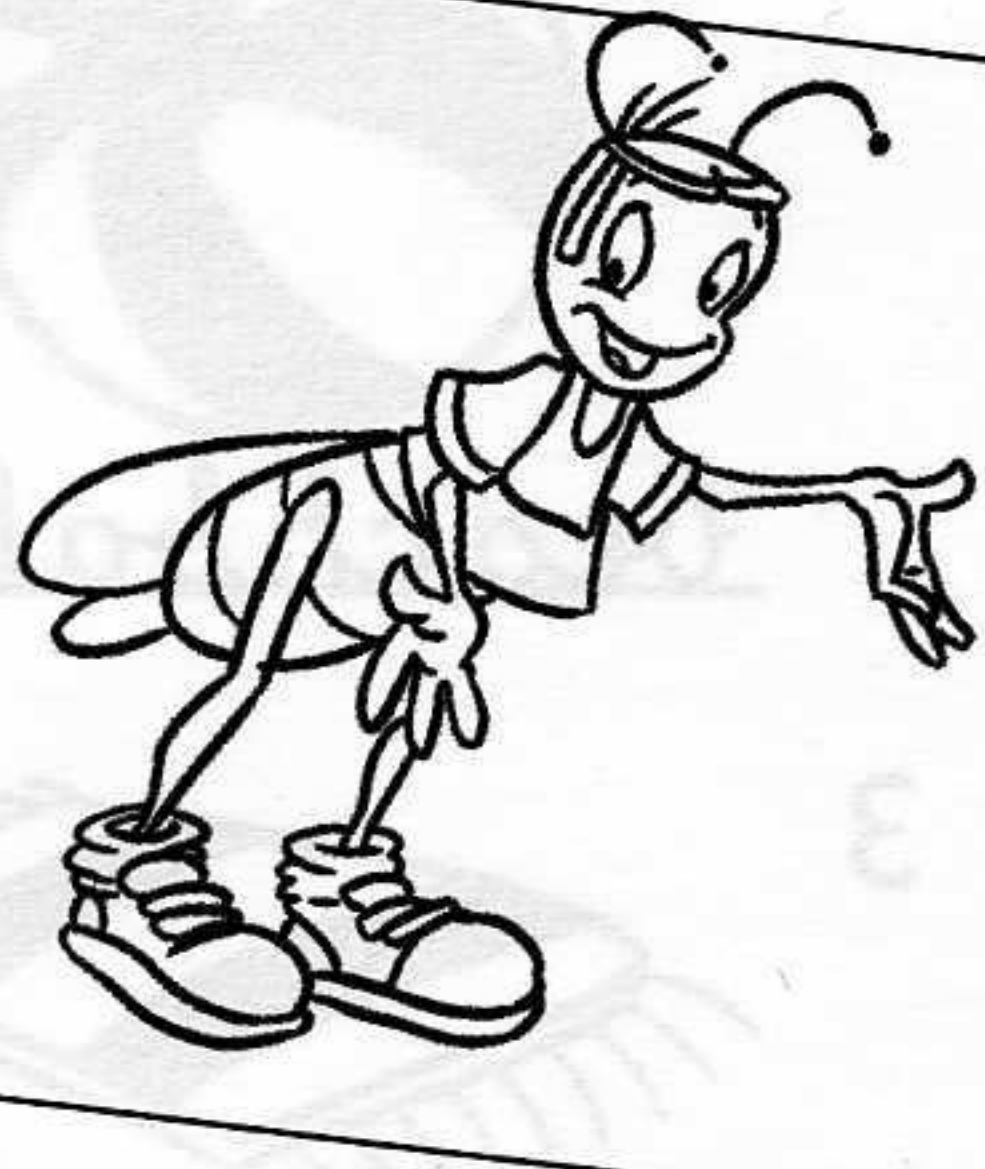

3 Dear Spike,
It's cold and it's snowing. I'm on holiday in the country.
Love,
Gracie



4 Dear Spike,
It's hot and it's sunny. I'm on holiday at the swimming pool.
Love,
Gracie

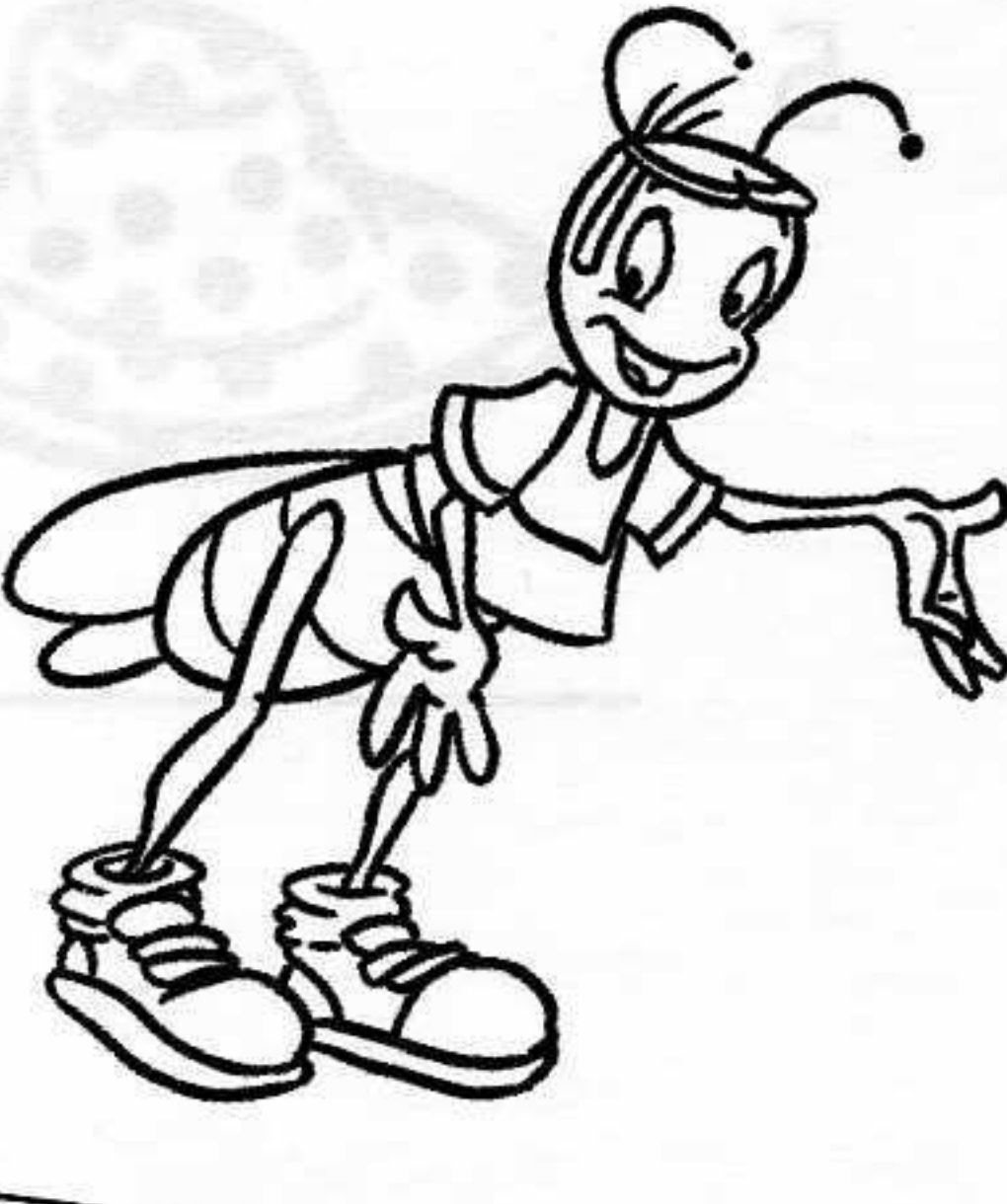

Unit 7 Activity 8



Read and write.

Where do the animals live?

penguins

tigers

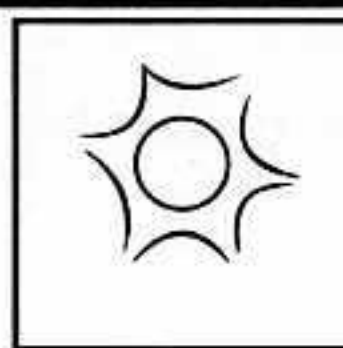
polar bears

Arctic	jungle
sea	Antarctic
jungle	jungle
HOT 	COLD 
crocodiles	

~~crocodiles~~

whales

gorillas

jungle

1 Crocodiles live in the jungle. It's hot and sunny.

2 Whales live in the _____ . It's cold.

3 Tigers _____ .

4 Polar bears _____ .

5 Gorillas _____ .

6 Penguins _____ .

PHOTOCOPIABLE

Unit 7 Activity 9

Circle and write.

1



beachball

3

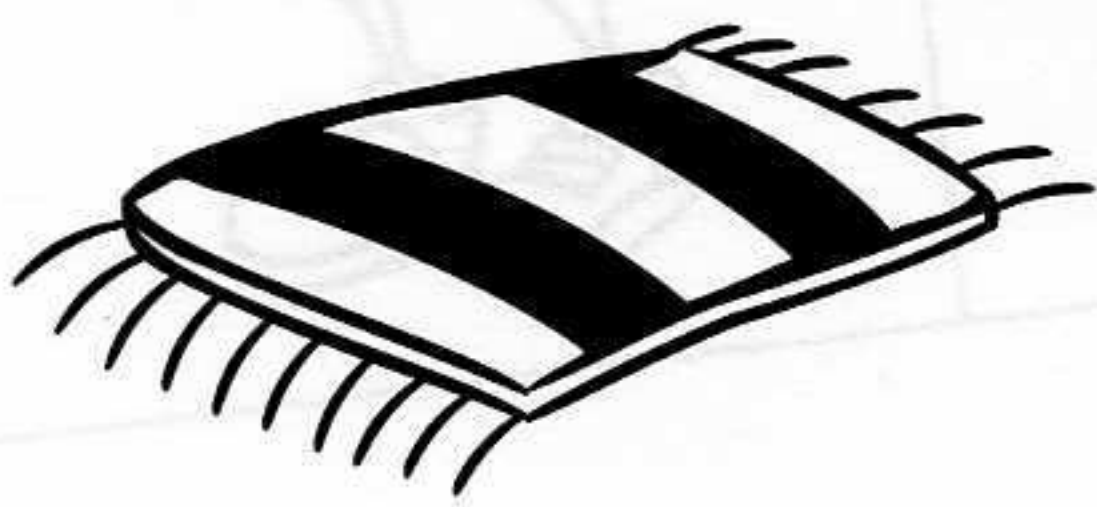

5

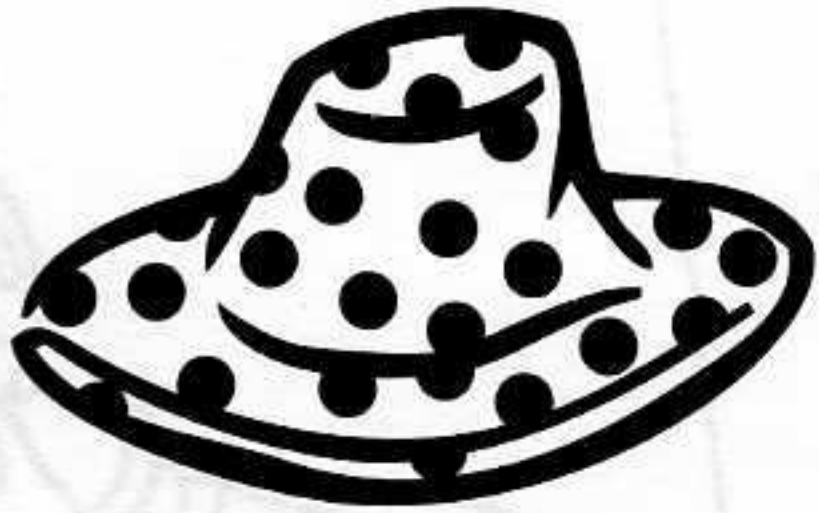

a	x	n	p	t	q	w	o	s
y	s	z	s	v	o	r	r	u
s	k	u	u	m	f	w	j	n
h	t	k	n	q	z	b	e	g
b	e	a	c	h	b	a	l	l
h	a	q	r	r	a	n	b	a
c	a	m	e	r	a	t	j	s
j	v	k	a	u	s	r	c	s
s	w	i	m	s	u	i	t	e
w	k	o	l	c	p	p	j	s

2

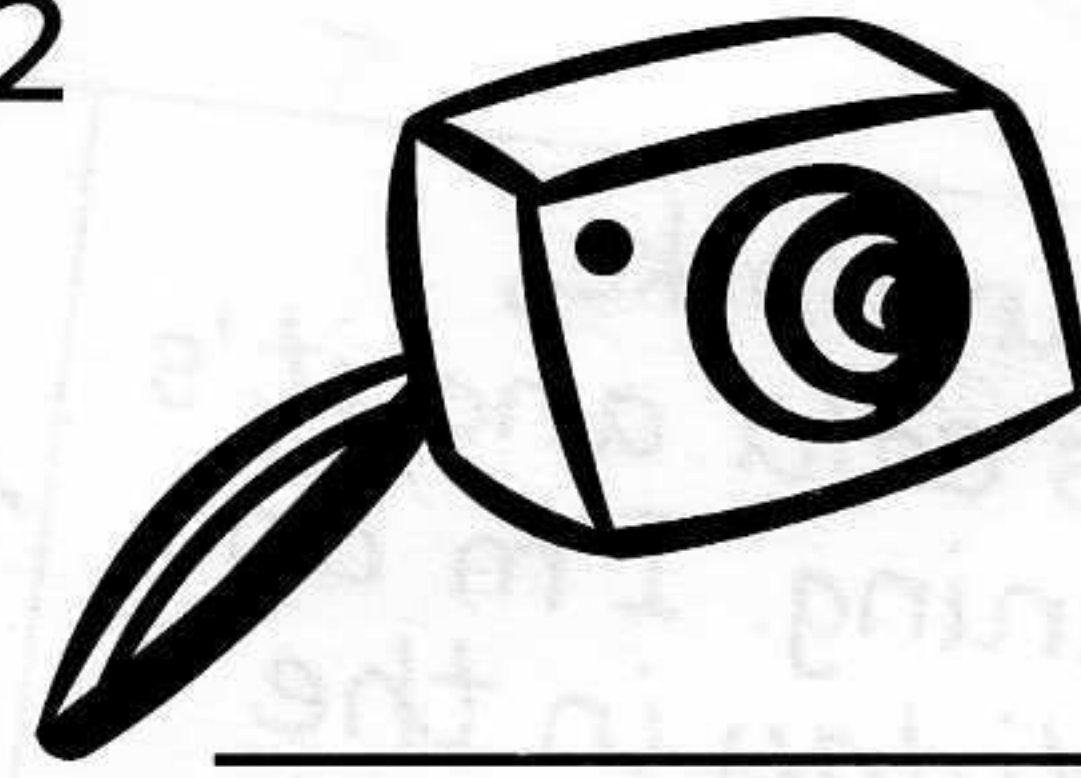

4



6



7

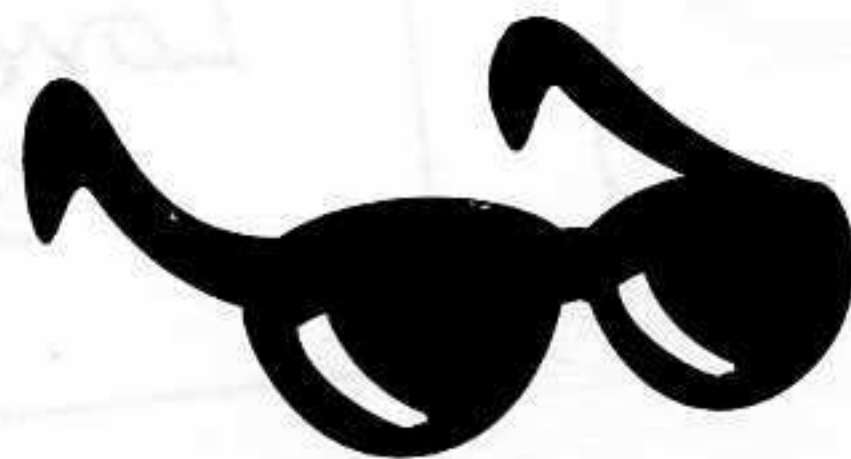

Unit 7 Activity 10

Look and write.

1



I've got sunglasses and swimming trunks
in my suitcase.

2



3



Unit 7 Activity 11

Read, match and write.

1

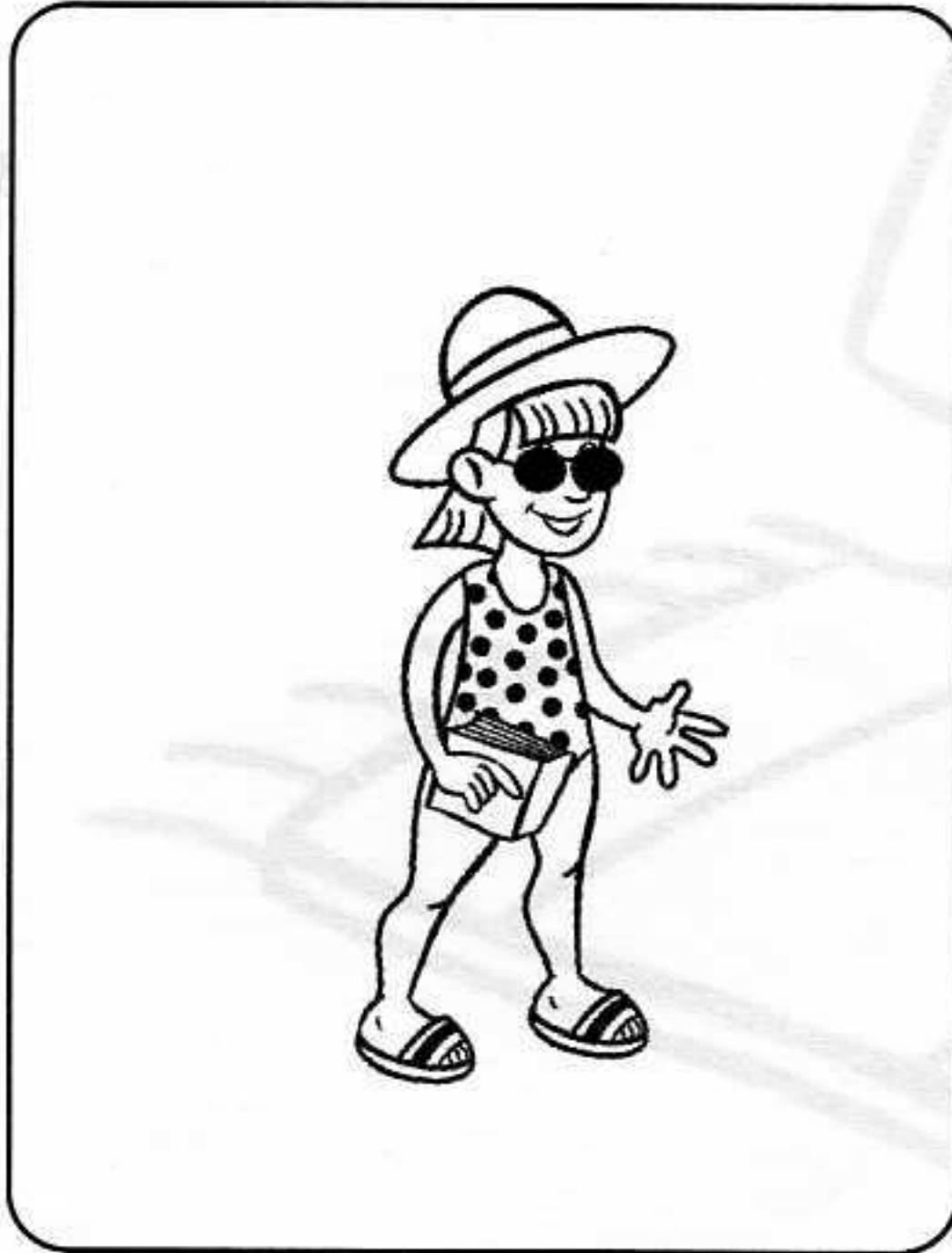

2

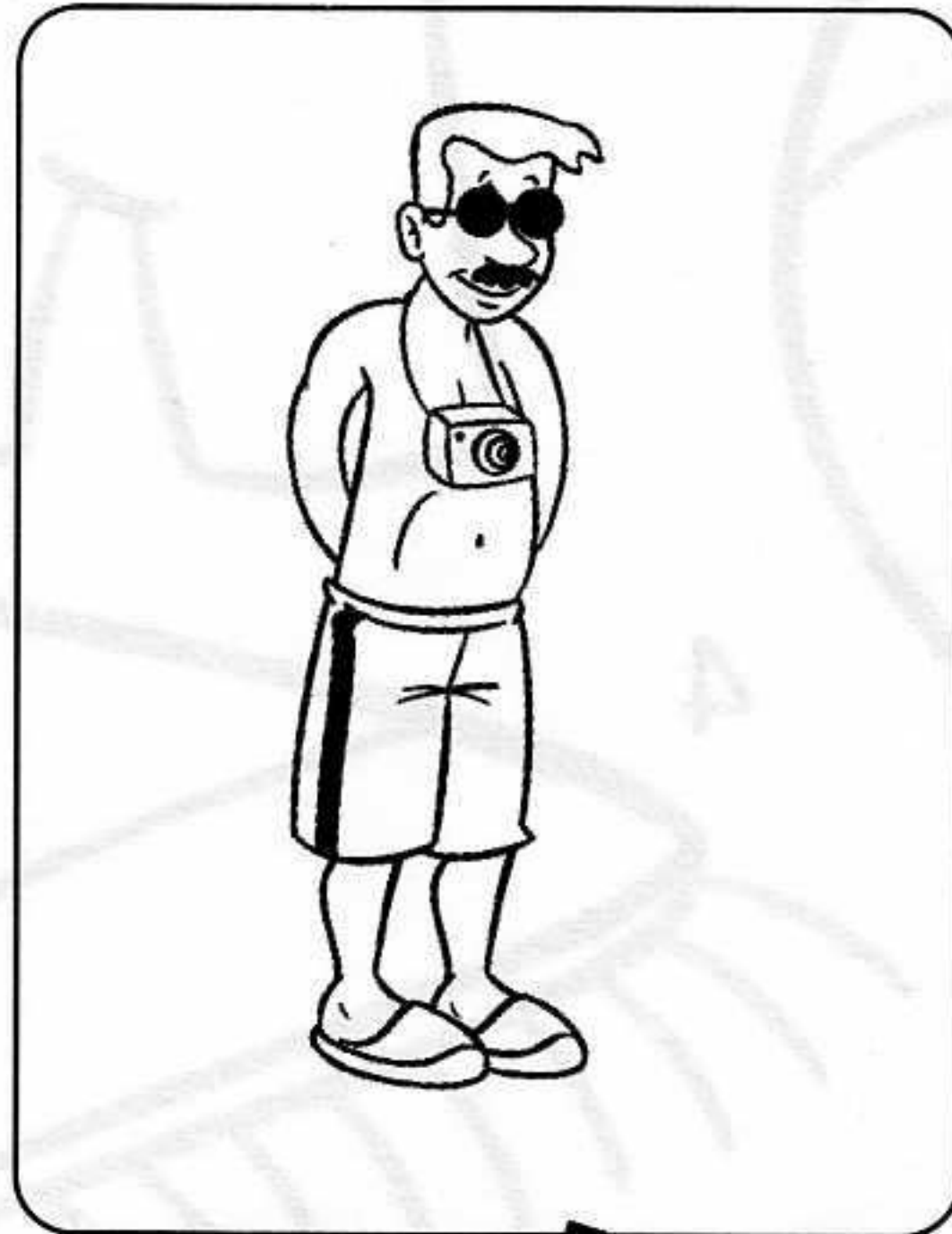

3



4



a

I'm wearing swimming trunks and sunglasses. I've got a camera.

b

I'm wearing swimming trunks and sunglasses. I've got a beachball.

c

I'm wearing a swimsuit, sunglasses and a sunhat. I've got a book.

d

I'm _____

Unit 7 Activity 12

Read, draw and colour.

I've got a red and white T-shirt and blue jeans in my suitcase.

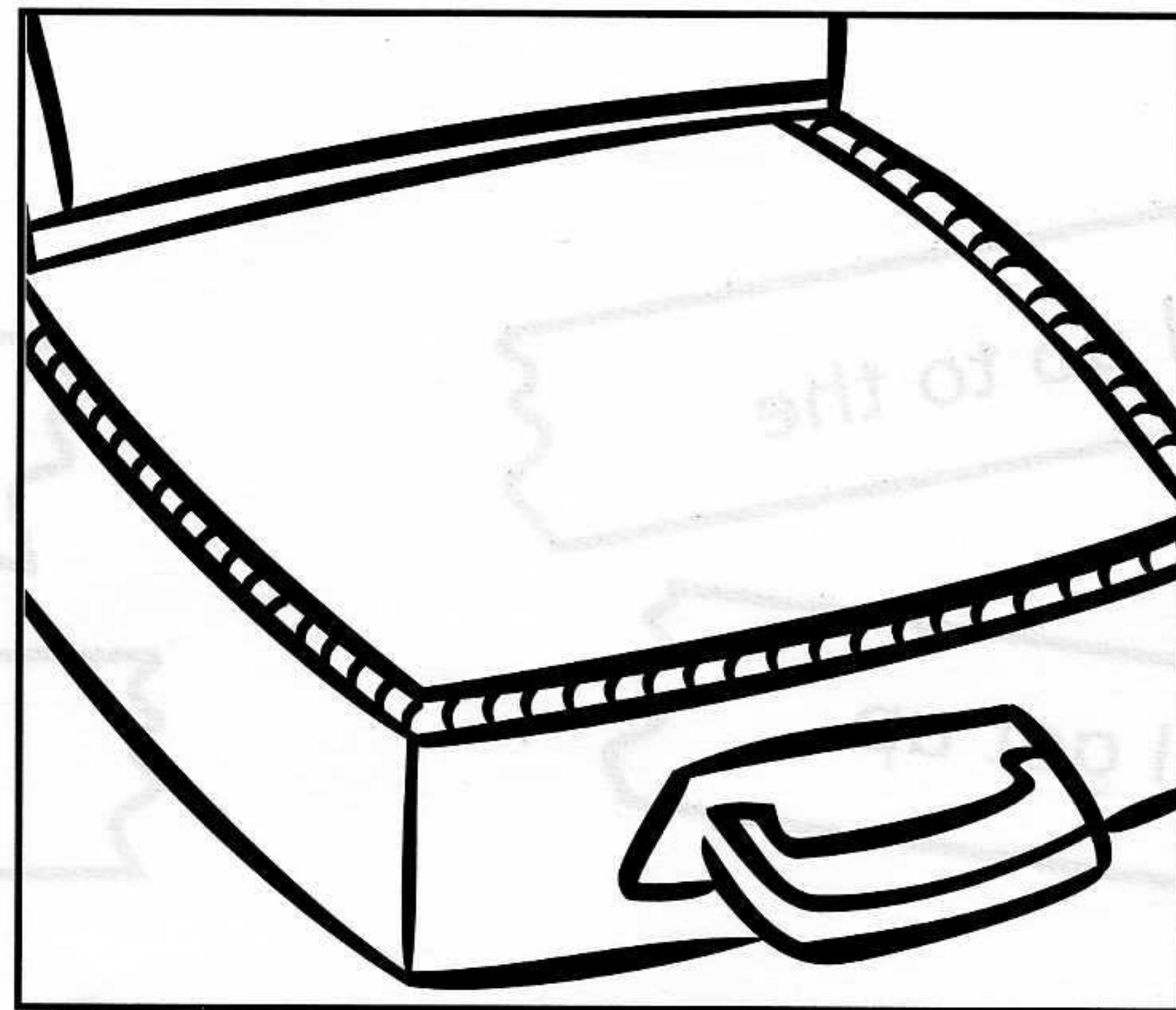

I've got a yellow and purple beachball and black swimming trunks in my suitcase.

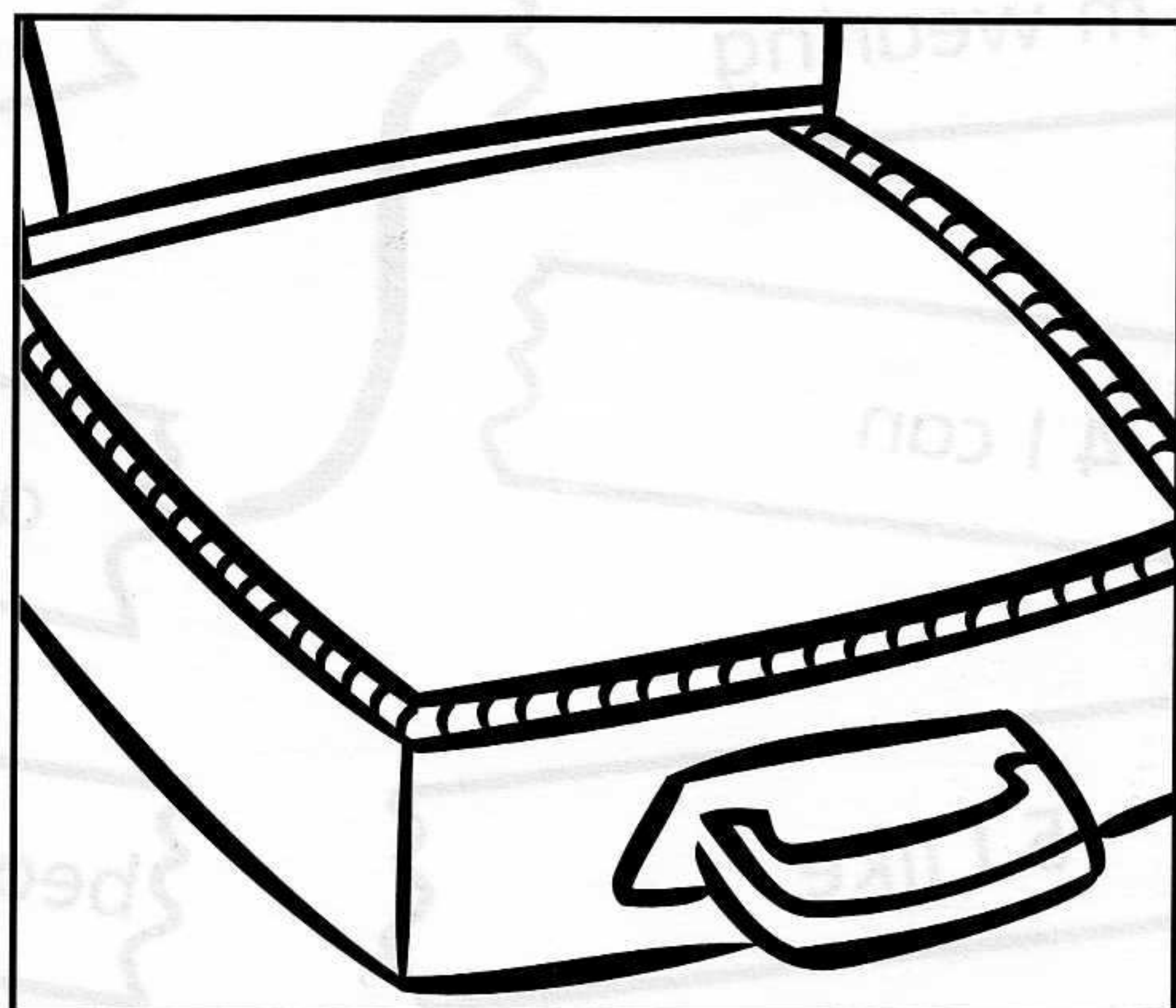

PHOTOCOPIABLE

Unit 7 Activity 15

Look and write.

1 Where's the beachball?

It's under the table

2 Where's the suncream?

3 Where's the camera?

4 Where's the sun hat?

5 Where's the swimsuit?

6 Where's the towel?



Unit 7 Activity 16

Write about you.

1 I like _____

2 I can _____

3 I've got a _____

4 I get up at _____

5 I'm wearing _____

6 I go to the _____ in summer.

Unit 8 Activity 1

Write. Find the secret word.

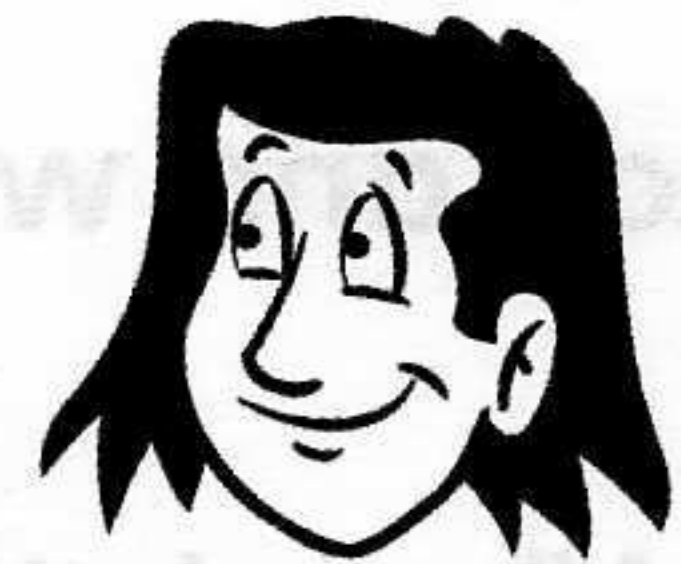

The secret word is .
 1 2 3 4 5

Unit 8 Activity 2

Read and match.

a 1 I'm wearing a hat, a coat and boots.

b 2 I'm wearing a hat, a coat, jeans and shoes.

c 3 I'm wearing a crown and boots.

d 4 I'm wearing a crown, a dress and shoes.

e 5 I'm wearing a dress, socks and shoes.

Unit 8 Activity 3

Read and number.

1

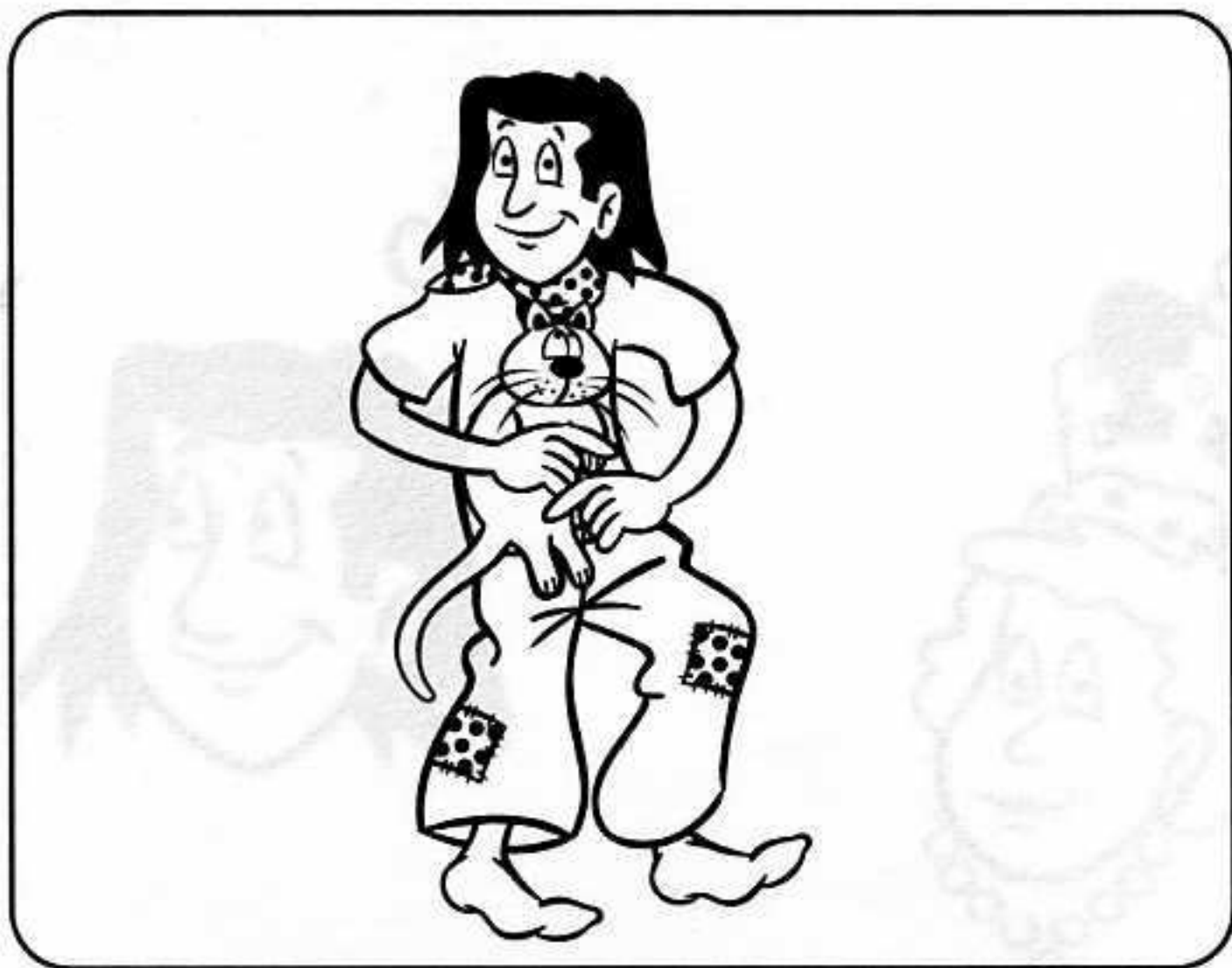

2



3



4



5



6

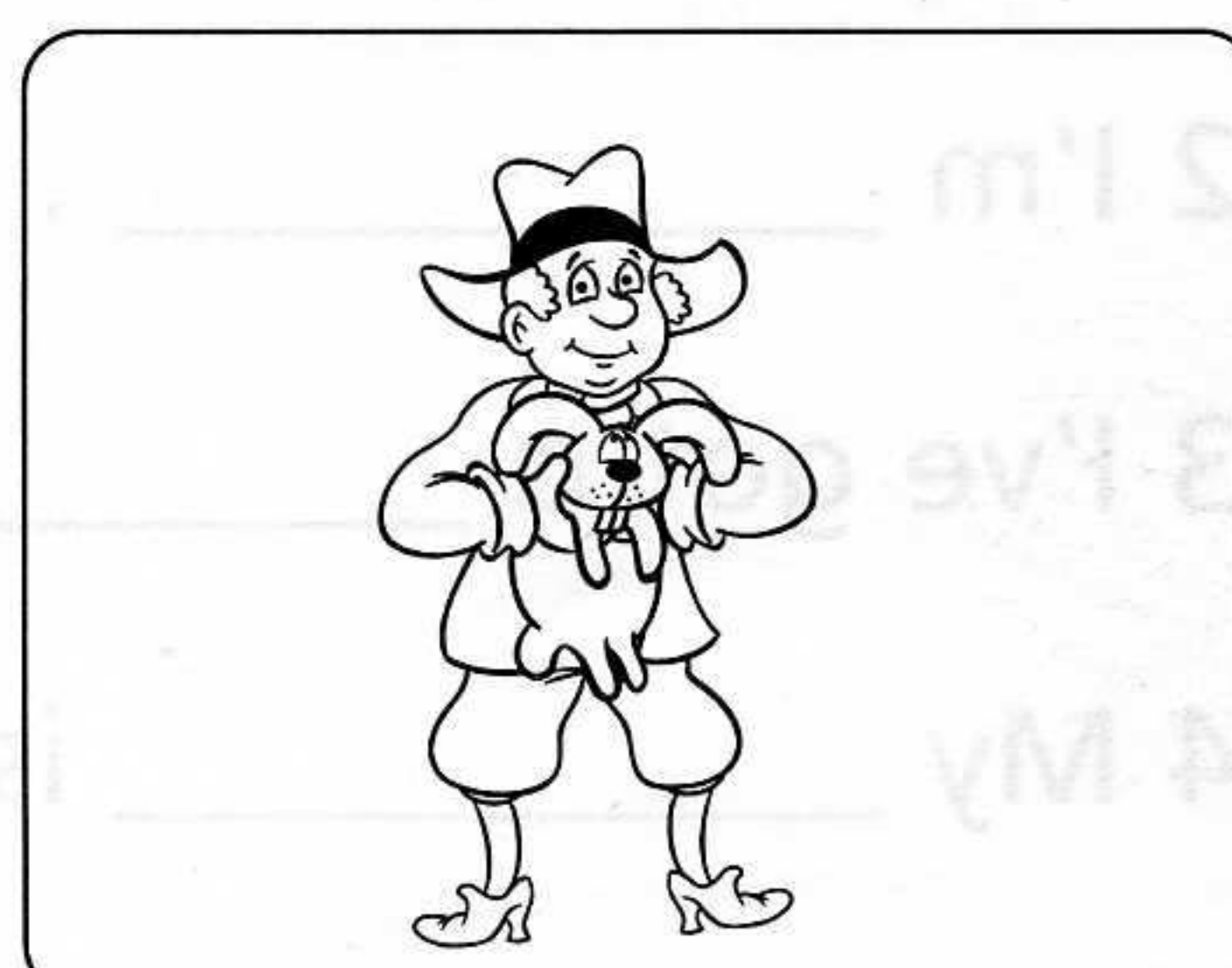

- a I've got a rabbit. 6 b I've got a fish. c I've got a hat.
 d I've got a cat. e I've got a hamster. f I've got a bird.

Unit 8 Activity 4

Order and write. Circle true (T) or false (F).



ride can He bike a

1 He can ride a bike. T F



play basketball can't She

2 _____ T F



He play football can't

3 _____ T F



play can She tennis

4 _____ T F

PHOTOCOPIABLE

Unit 8 Activity 5

Read, write and match.

daughter	dad
boots	rich
	live
	clever

1 I live in a palace.

2 I'm _____.

3 I've got a _____ cat.

4 My _____ is the princess.

5 I'm wearing _____ and a hat.

6 My _____ is the king.

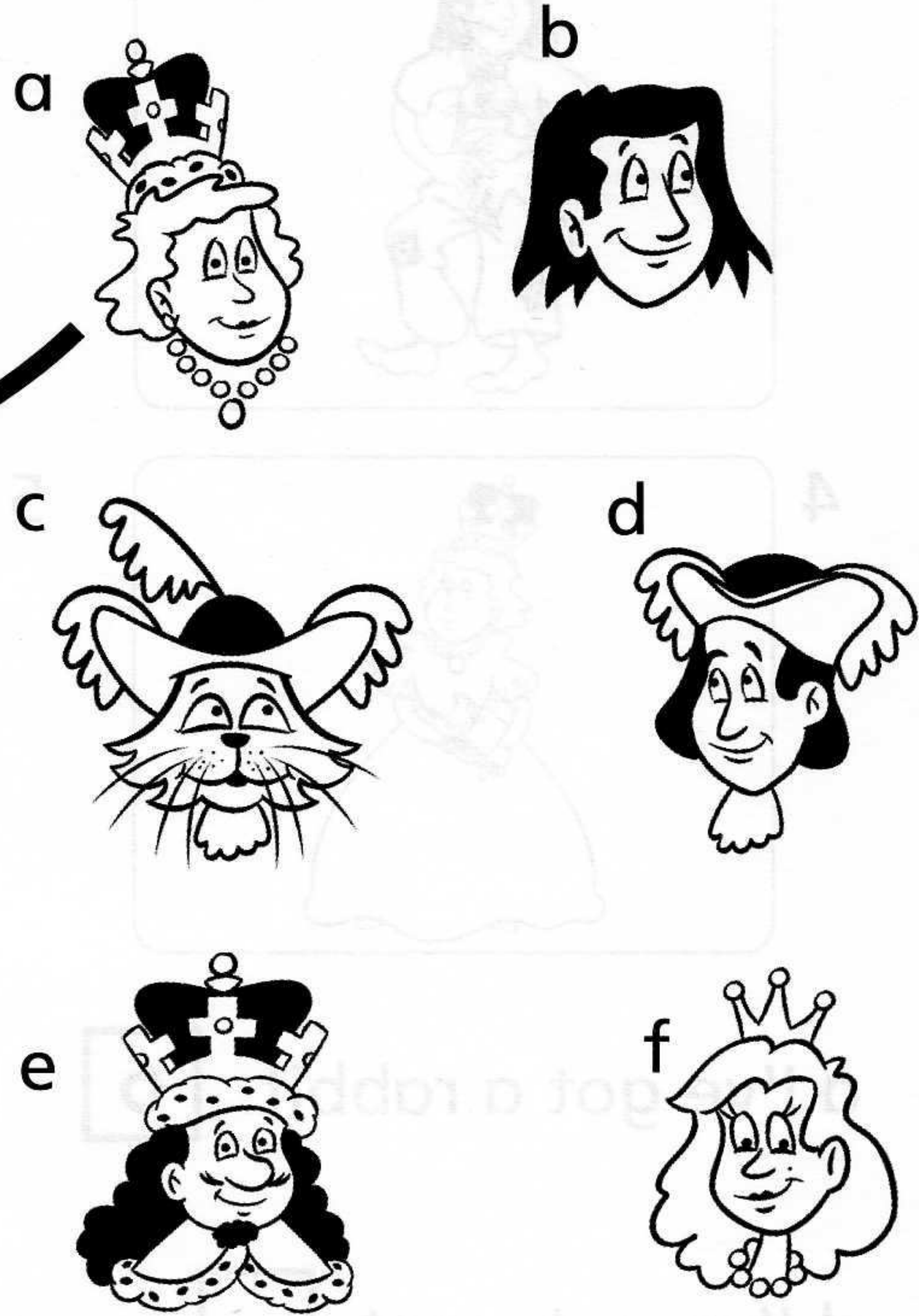

Unit 8 Activity 6

Find and write.

1 Where's Puss in boots?

He's in the river.

2 Where's the princess?

3 Where's the king?

4 Where's the queen?

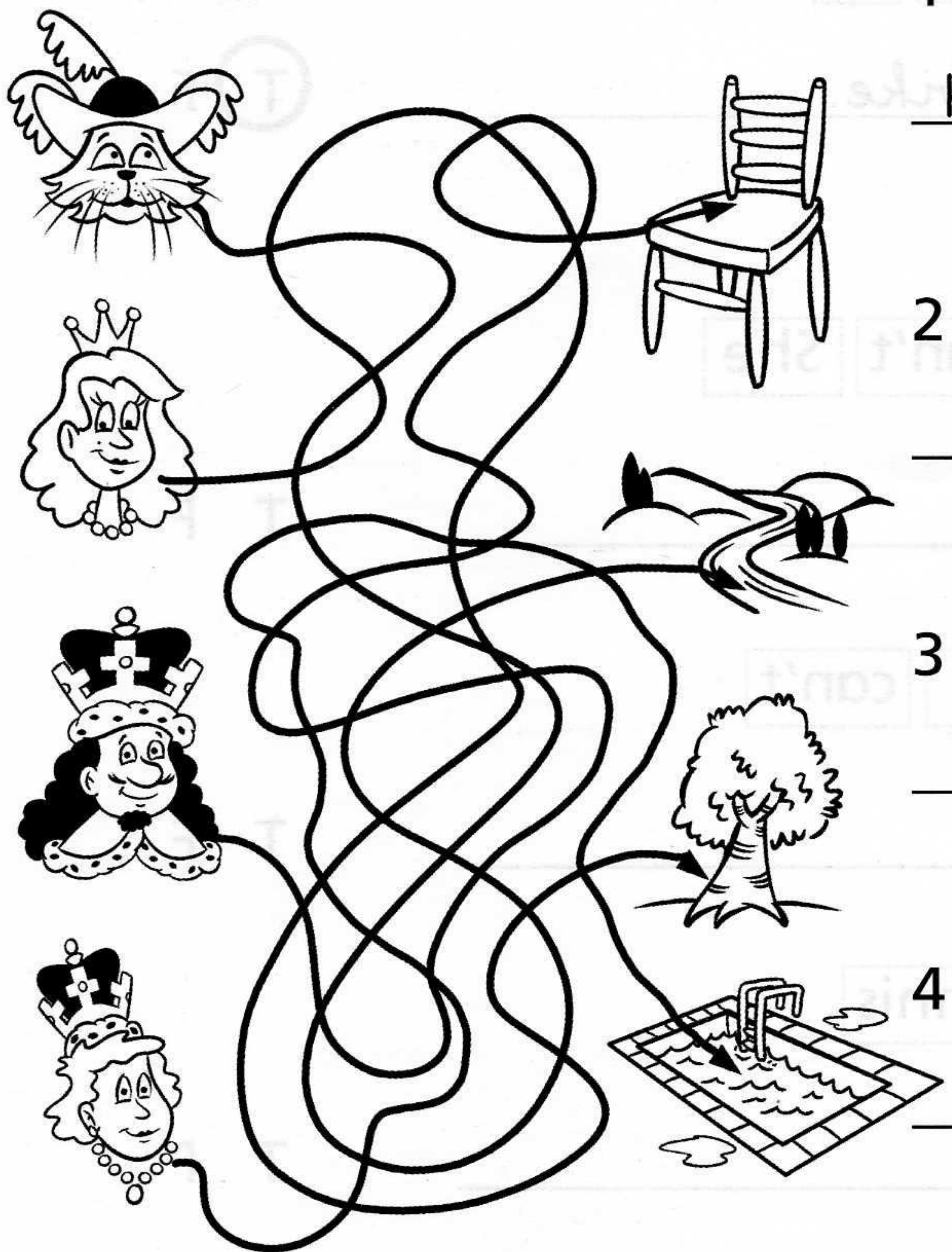

Unit 8 Activity 5

Read, write and match.

daughter	dad
boots	rich
	live
	clever

1 I live in a palace.

2 I'm _____.

3 I've got a _____ cat.

4 My _____ is the princess.

5 I'm wearing _____ and a hat.

6 My _____ is the king.

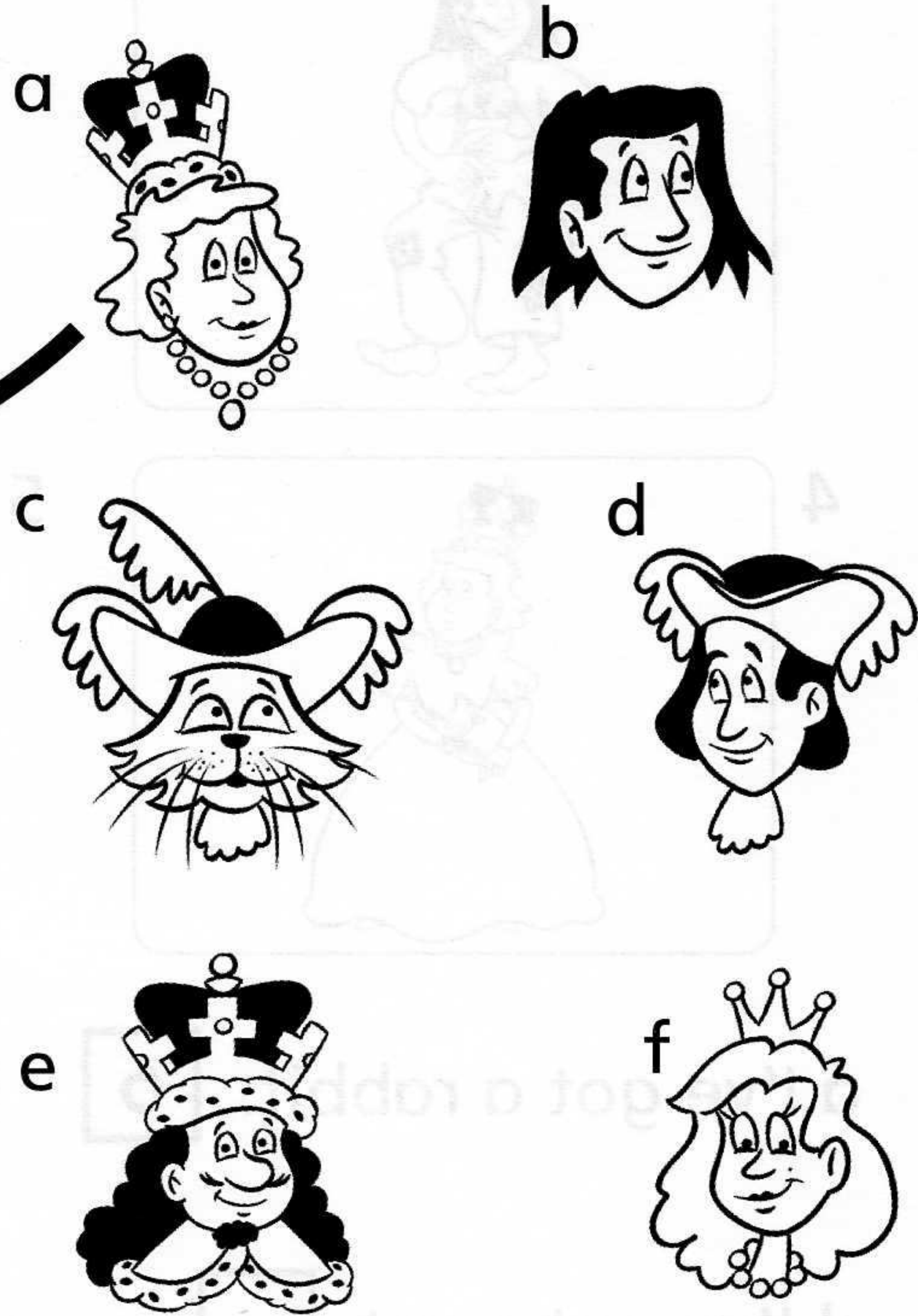

Unit 8 Activity 6

Find and write.

1 Where's Puss in boots?

He's in the river.

2 Where's the princess?

3 Where's the king?

4 Where's the queen?

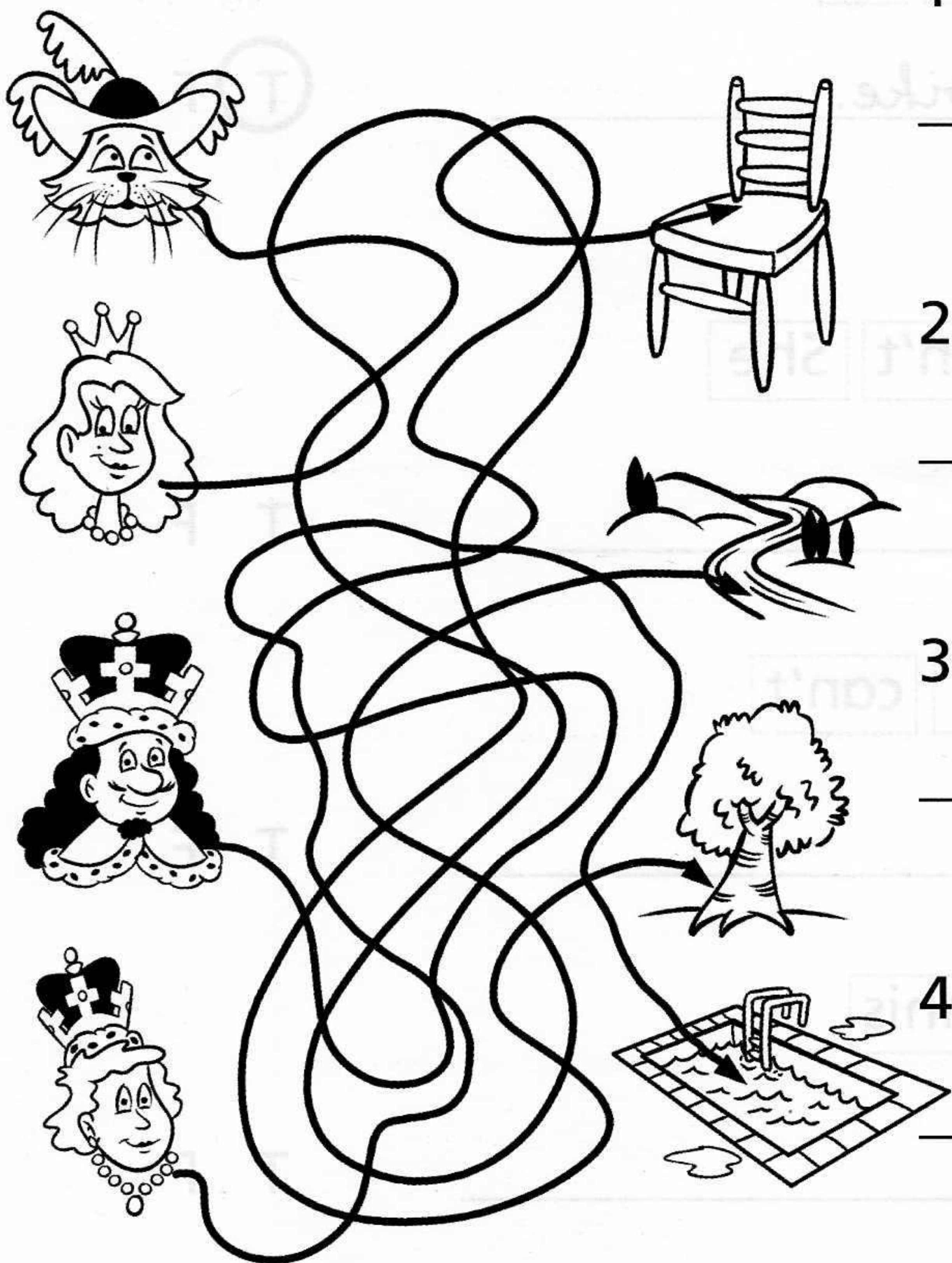

Unit 8 Activity 7

Read and write.

play tennis sunny get up
ice cream lunch two o'clock
beach eleven o'clock swim

Dear Puss in boots,

It's hot and sunny. I'm at the beach.

I get up at two o'clock. I have lunch

at eleven o'clock. I play tennis and swim

in the afternoon. I eat ice cream every day.

Love, John

Unit 8 Activity 8

Look and write.

1 MY SUITCASE

towel

2 HOLIDAY PLACES

beach

PHOTOCOPIABLE

Unit 8 Activity 9

Look and circle.



1 I'm rich / poor

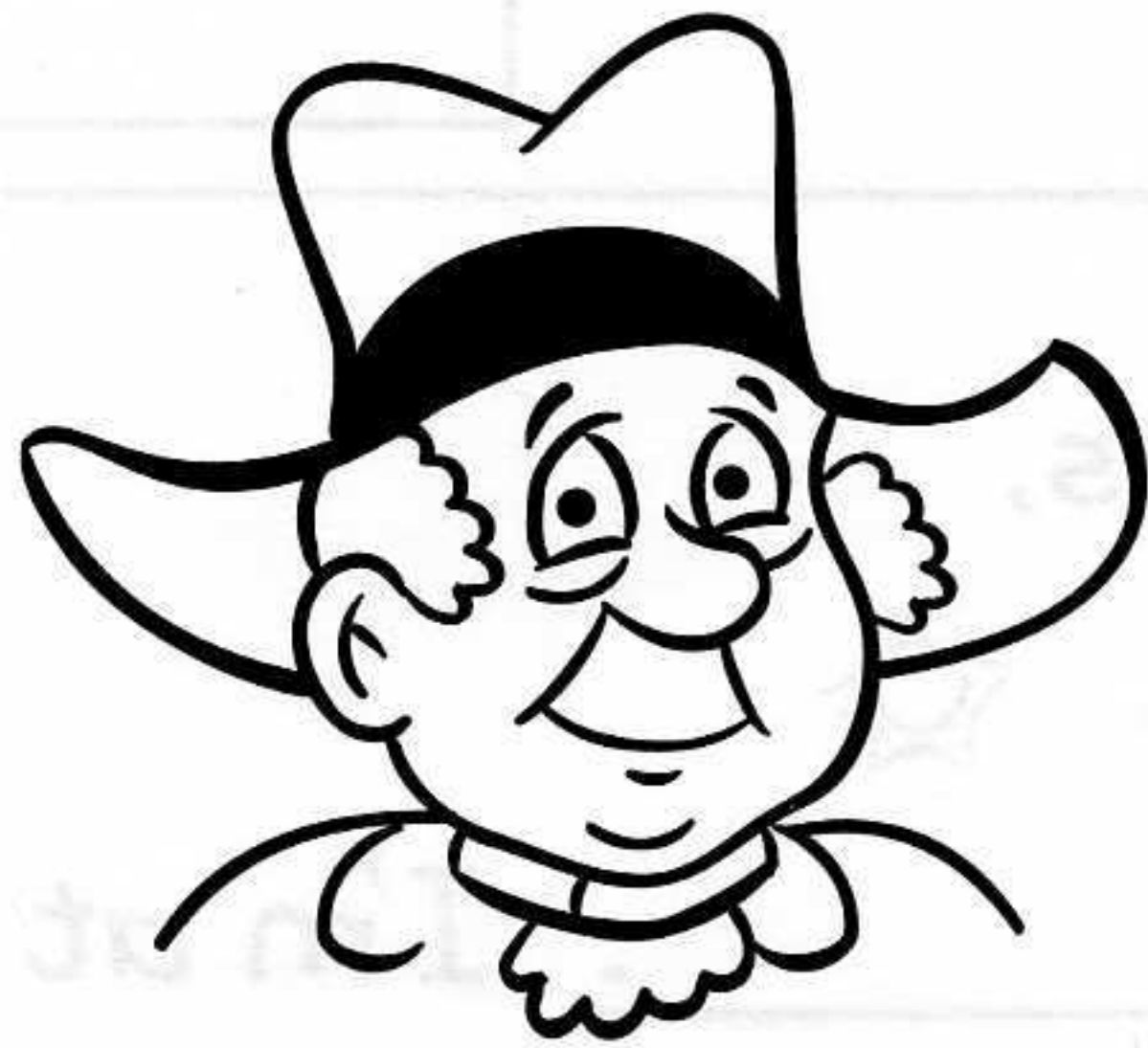

2 I'm old / young



3 I'm old / young



4 I'm rich / poor



5 I'm clever / stupid



6 I'm handsome / ugly

Unit 8 Activity 10

Look and write.



1 What's Puss in boots wearing?

He's wearing a coat, hat and boots.

2 What's John wearing?

3 Who is handsome?

4 Who is rich?

5 Who is clever?

Unit 8 Activity 11

Read, draw and colour.

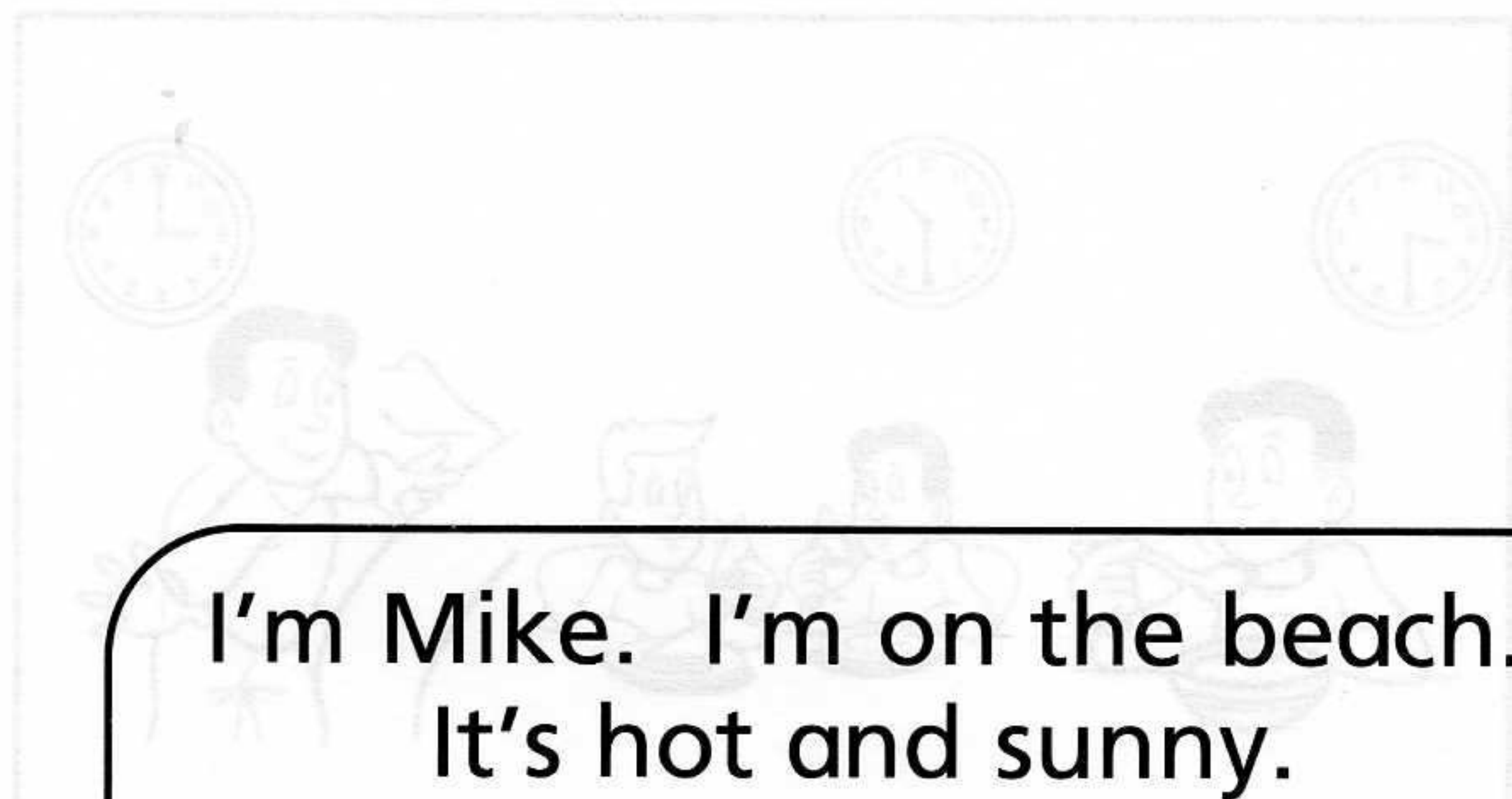

I'm Mike. I'm on the beach.
It's hot and sunny.

I'm wearing green and red
swimming trunks, blue
sunglasses and a red hat. I've
got a yellow and orange
beachball.

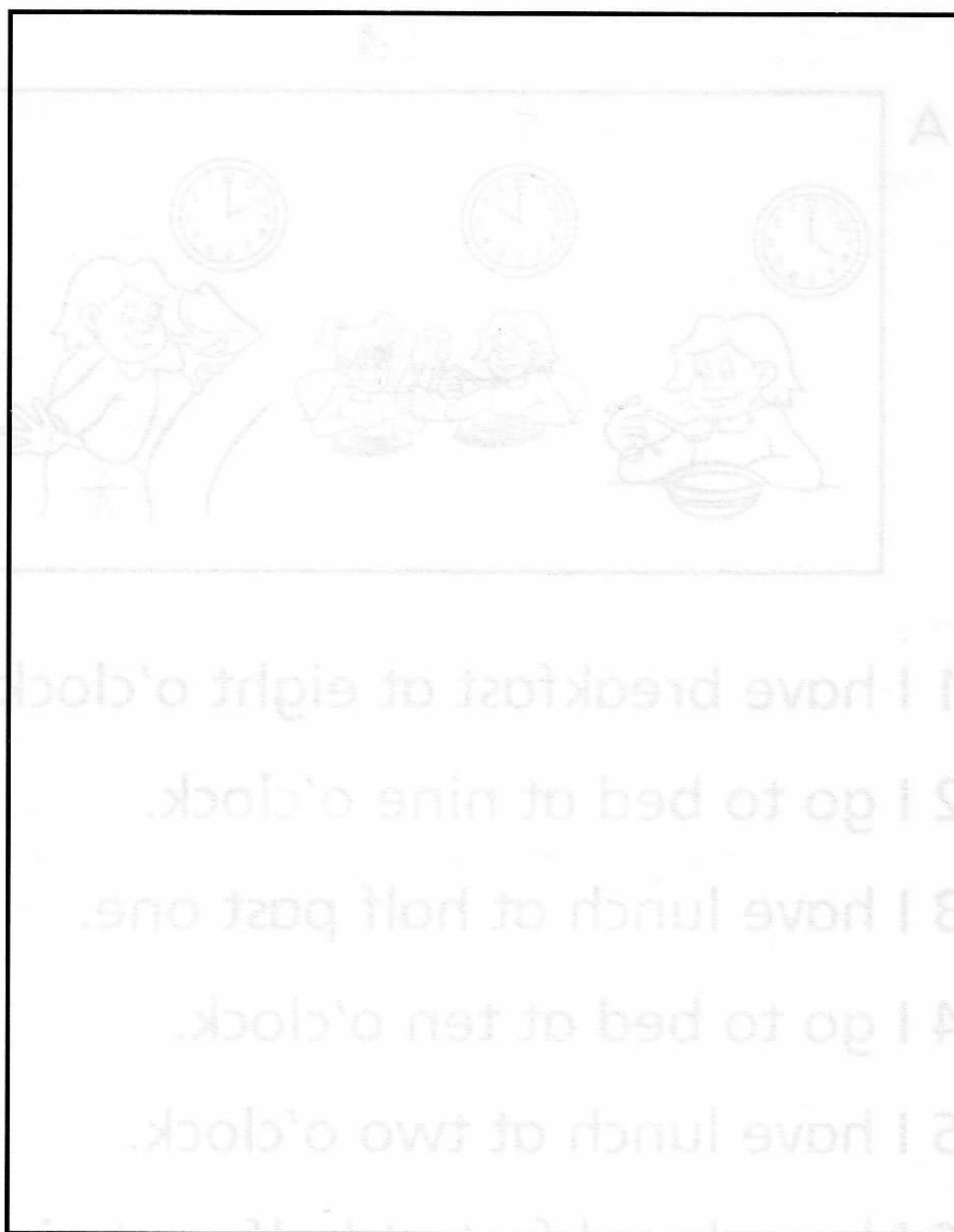

Unit 8 Activity 12

Read and write.

	... is can can't 's got 's wearing
DAVID	young, handsome	play football	play tennis	ball	T-shirt, jeans, trainers
AMANDA	young, clever	rollerblade	ride a bike	sunglasses	dress and shoes
PAUL	old, clever	play tennis	rollerblade	sunglasses	T-shirt, jeans, hat

1 David is young and handsome. He's got a ball. He can play football,
but he can't play tennis. He's wearing a T-shirt, jeans and trainers.

2 Amanda _____

3 _____

Unit 8 Activity 13

Read and write A or B.

A

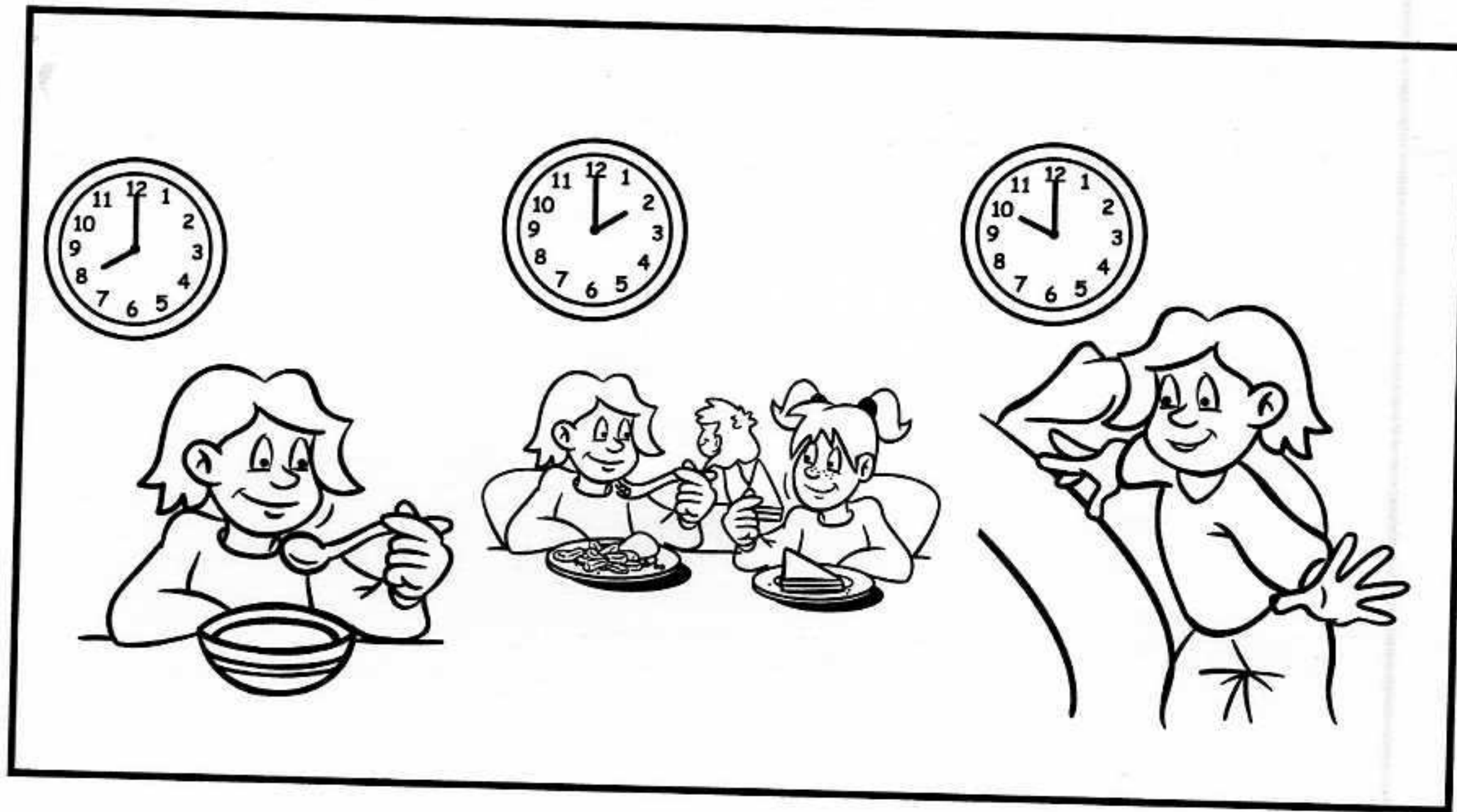

B

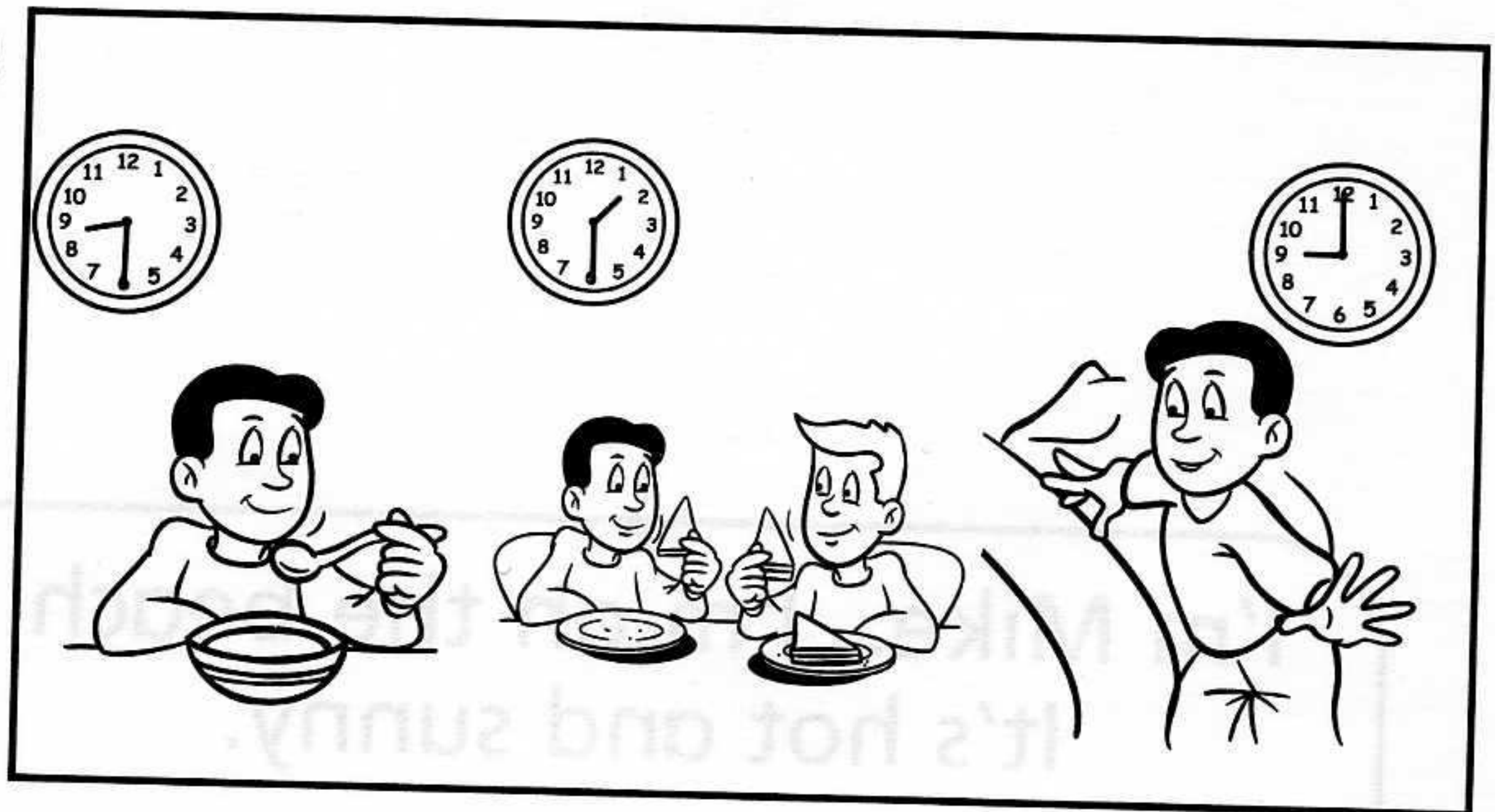

- 1 I have breakfast at eight o'clock.
- 2 I go to bed at nine o'clock.
- 3 I have lunch at half past one.
- 4 I go to bed at ten o'clock.
- 5 I have lunch at two o'clock.
- 6 I have breakfast at half past eight.

A

Unit 8 Activity 14

Look and write.



This is the _____ .
 She's got _____ . She's
 wearing _____ and
 _____ . She's
 under _____ .

Unit 8 Activity 15

Look and write.



I've got a fish and a
bird.





Unit 8 Activity 16

Read and write.

pencil	school bag	white	snake	lake
leopard	notebook	chair	gorilla	black
brown	tiger	swimming pool	beach	ruler
				mountains
				pencil case
				whale
				blue
				pink

1 SCHOOL

notebook

2 ANIMALS

snake

3 COLOURS

brown

4 PLACES

lake

PHOTOCOPIABLE

Answer Key

Unit 1

1

e	o	n	b	y	c	r	e	d
a	o	b	t	w	k	w	f	h
v	e	l	l	o	w	h	g	o
r	q	u	d	f	h	i	j	r
p	x	e	m	p	p	t	w	a
i	g	c	c	g	r	e	e	n
n	t	b	l	a	c	k	v	g
k	h	s	p	u	r	p	l	e
c	f	b	r	o	w	n	y	w

The nine colours are: white, red, yellow, green, black, purple, brown, pink, orange.

2

2 ruler, 3 notebook, 4 chair, 5 pen, 6 school bag

3

2 F, 3 T, 4 F, 5 F, 6 T, 7 T

4

2 It's a desk.
3 It's a ruler.
4 It's a school bag.
5 It's a chair.

5

1 It's under the chair.
2 It's in the school bag.

6

2 It's in the notebook.
3 It's on the chair.
4 It's on the desk.

7

Bag 1 Mark - b
Bag 2 Sam - c
Bag 3 Wendy - d
Bag 4 Susan - a

8

2 It's under the chair.
3 It's in the school bag.
4 It's on the ruler.

9

2 tortoise, 3 bird, 4 fish, 5 dog, 6 grasshopper

10

Children's own work.

11

2 T, 3 F, 4 T, 5 T

12

2 It's on the chair.
3 It's under the chair.

4 It's in the bowl.

5 The grasshopper is under the desk.

6 It's on the chair.

13

2 Grasshopper, 3 Hamster, 4 Bird, 5 Dog, 6 Fish

14

b 1, c 3, d 4

15

Children's own work.

16

2 two, 3 eight, 4 one, 5 eight, 6 three, 7 seven, 8 four, 9 nine

Unit 2

1

2 socks, 3 trainers, 4 T-shirt, 5 jeans, 6 dress

2

2 red shoes, 3 green socks,
4 a blue T-shirt, 5 orange trainers,
6 pink jeans

3

2 T-shirt, 3 dress, 4 jeans, 5 socks,
6 shoes, 7 trainers, 8 coat

4

2 f, 3 b, 4 e, 5 d, 6 a

5

2 No, she isn't.
3 Yes, he is.
4 Yes, she is.
5 No, he isn't.
6 Yes, she is.
7 Yes, she is.

6

2 F, 3 F, 4 T, 5 T, 6 T, 7 F

7

1 He's wearing socks / a T-shirt / jeans.
2 He's wearing / a T-shirt / a hat / trainers.
3 She's wearing a hat / a T-shirt / trainers.
4 She's wearing shoes / a dress / a hat.

8

2 Daniel is wearing a T-shirt, jeans, a hat and trainers.
3 Sue is wearing a dress, socks and shoes.
4 Marcus is wearing jeans, a coat and trainers.

g	e	g	e	d	j	s	s	e	m
d	b	h	t	f	k	u	h	l	u
b	s	r	h	b	o	s	k	i	m
a	l	c	o	u	s	i	n	g	d
c	d	s	k	t	l	s	l	s	g
k	o	a	l	j	h	t	d	a	d
o	t	u	n	c	l	e	e	u	o
l	r	c	s	s	d	r	r	n	a
m	e	k	a	b	a	w	c	t	e
p	r	s	b	c	d	a	e	f	g

9

1 cousin, 2 dad, 3 mum, 4 uncle, 5 aunt, 6 sister, 7 brother

10

2 They're on the desk.
3 It's on the school bag.
4 It's under the desk.
5 It's on the chair.
6 They're under the desk.

11

2 two hats, 3 five T-shirts, 4 eight tables, 5 ten chairs, 6 three coats, 7 nine hamsters, 8 two school bags, 9 six grasshoppers, 10 seven tortoises

12

Children's own work.

13

2 He's Dad.
3 She's cousin Ann.
4 He's Uncle Thomas.
5 She's Auntie Julia.

14

1 Clothes: coat, socks, hat, dress, jeans, shoes, trainers.
2 Family: auntie, brother, sister, uncle, dad, cousin.
3 Classroom: pen, school bag, chair, ruler, desk.
4 Animals: hamster, bird, grasshopper, dog, fish.

15

Children's own work.

16

2 It's on the chair.
3 It's in the school bag.
4 It's on the chair.
5 It's under the desk.
6 It's on the chair.
7 It's under the desk.
8 It's on the chair.

Unit 3

1

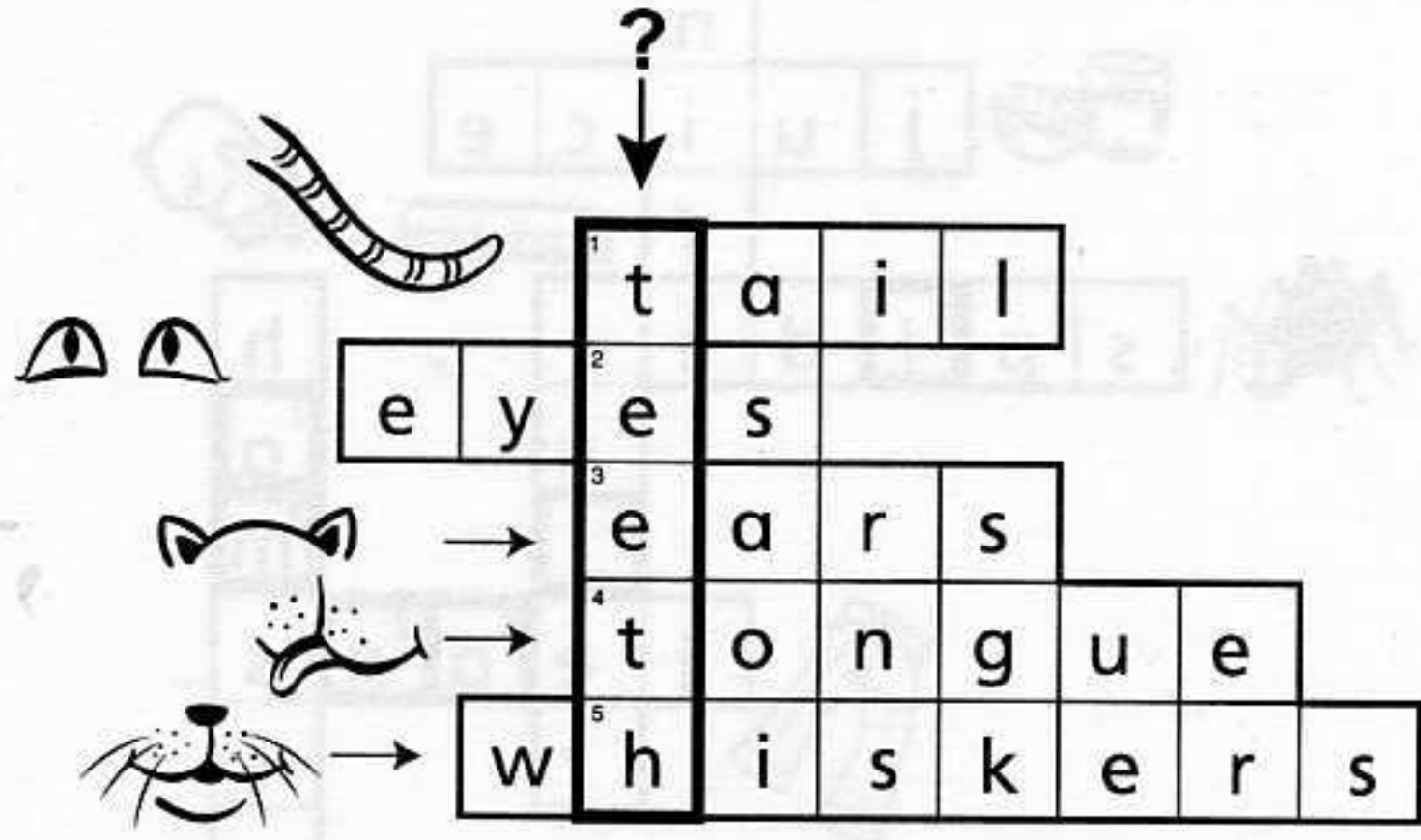

The secret word is t e e t h.
1 2 3 4 5

2

2 a, 3 d, 4 c

3

Possible answers:

No legs: snake, fish

Two legs: bird, gorilla

Four legs: cat, dog, leopard, crocodile, hamster, tortoise

Eight legs: spider

4

Children's own pictures.

2 I haven't got legs.

3 I haven't got whiskers.

4 I haven't got a mouth.

5 I haven't got a tail.

6 I haven't got a body.

5

Children's own work.

6

1 Four eyes, 2 Twenty whiskers,

3 Two tails, 4 Three tongues

7

2 I've got a big body. False

3 I've got two eyes and whiskers. True

4 I haven't got a long tail. False

8

Possible answers:

1 I haven't got legs.

2 I've got whiskers. I haven't got a tail.

3 I've got four legs. I haven't got wings.

9

Children's own answers using Yes, I have or No, I haven't.

10

2 fish, 3 snake,

4 gorilla, 5 leopard

11

2 It's on the chair.

3 It's under the desk.

4 It's under the chair.

12

2 crocodile, 3 crocodile, 4 crocodile,

5 crocodile, 6 gorilla

13

2 I live in the sea.

3 I live in the grasslands.

4 I live in the jungle.

14

1 Numbers: one, three, six, nine

2 Animals: crocodile, bird, whale, gorilla

3 Clothes: trainers, jeans, coat, T-shirt

15

1c, 2b, 3d, 4a.

16

Children's own work

Unit 4

1

2 ice cream, 3 fish, 4 salad, 5 sausages,

6 rice, 7 chips

2

2 black - numbers, 3 rice - school, 4 chips - animals, 5 fish - colours

3

2 don't like, 3 don't like, 4 like,

5 don't like, 6 like

4

2 I don't like rice.

3 I like sausages.

4 I like macaroni.

5 I don't like fish.

Maria			✓	✗			✗
Susan				✓	✓	✗	✗
Victor	✓		✗			✗	✓
Paul	✗	✓		✓	✗		

5

6

2 I like fish and chips.

3 I like salad and juice.

4 I don't like macaroni.

5 I like rice and ice cream.

7

2 A, 3 B, 4 B, 5 B, 6 A

8

2 Do you like ice cream? No, I don't.

3 Do you like rice? Yes, I do.

4 Do you like chips? No, I don't.

9

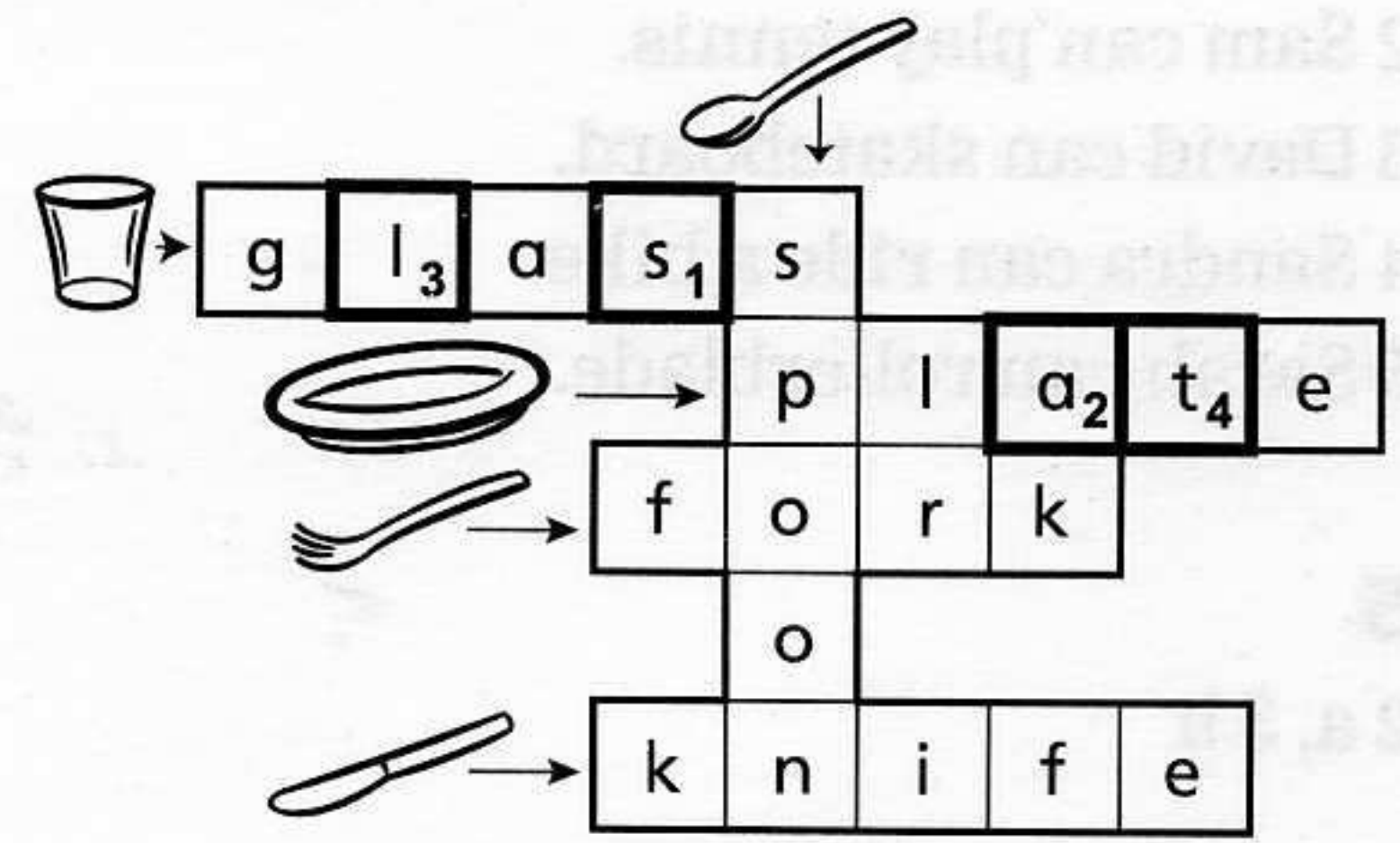

The secret word is: s a l t.
1 2 3 4

10

2 It's on the plate.

3 It's on the plate.

4 It's in the glass.

5 It's under the table.

11

1 Can I have sausages and chips, please?

2 Can I have macaroni and ice cream, please?

3 Can I have fish and rice, please?

12

a 2, b 4, c 1, d 3

13

Letter reads:

I'm Daniel. I'm nine. My favourite colour is blue. I've got a dog. It's brown and white. It's got a long tail.

I like fish and salad. I don't like macaroni or rice. My favourite food is ice cream.

14

2 fifteen knives, 3 twenty plates, 4 16 spoons, 5 seven glasses

15

2 T, 3 F, 4 F

16

2 In the sea.

3-6 Children's own answers.

7 Yes, they have.

Unit 5

1

2 skateboard, 3 play football, 4 ride a bike, 5 play basketball, 6 rollerblade

2

2 c, 3 d, 4 f, 5 g, 6 a, 7 b

3

2 I'm Mark. I've got a tennis racket, but I can't play tennis.

3 I'm Sandra. I've got a bike. I can ride it.

4 I'm Chloe. I've got rollerblades, but I can't play with them.

4

- 2 Sam can play tennis.
- 3 David can skateboard.
- 4 Sandra can ride a bike.
- 5 Sarah can rollerblade.

5

- 2 a, 3 b

6

- 2 T, 3 F, 4 F, 5 T, 6 T

7

Possible answers:

- 2 Emily can ride a bike, but she can't play football.
- 3 Archie can play tennis, but he can't play basketball.
- 4 Archie can play football, but he can't rollerblade.
- 5 Mike can play basketball, but he can't ski.
- 6 Mike can rollerblade, but he can't ride a bike.

8

- 2 Can you play basketball? No, I can't.
- 3 Can you ski? Yes, I can.
- 4 Can you play football? Yes, I can.
- 5 Can you play tennis? No, I can't.
- 6 Can you ride a bike? Yes, I can.

9

- thirty-nine, sixteen, forty-two, twenty-three, forty-eight, twenty-seven, fifteen, thirty-five, thirty

10

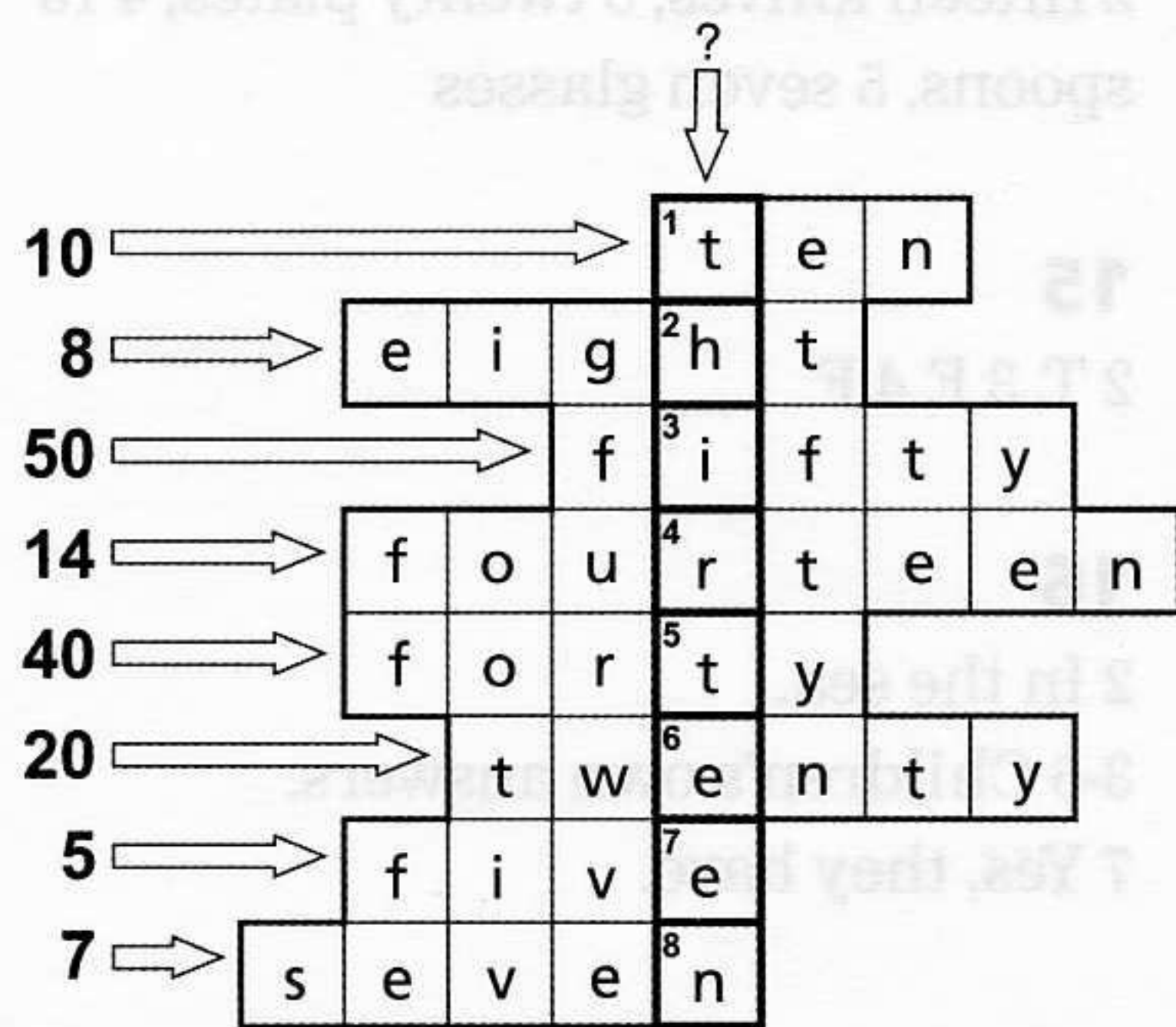

The secret word is: t h i r t e e n.
1 2 3 4 5 6 7 8

Write the number: 13.

11

- Children should have drawn:
- 1 a crocodile, 2 a leopard or tiger,
- 3 a snake, 4 a spider

12

- 1 eighteen, twenty, twenty-two
- 2 fifteen, twenty-five, forty
- 3 twenty, twenty-eight, thirty-six
- 4 thirteen, seventeen, twenty-three
- 5 fourteen, thirty-five, forty-nine
- 6 eighteen, thirty, thirty-six

13

- 1 colours: red, pink, purple, white, brown, green, blue
- 2 animals: gorilla, snake, tiger
- 3 body: tongue, ears, tail

14

- 2 B, 3 A, 4 A, 5 A, 6 A

15

- 2 No, she can't.
- 3 Yes, he can.
- 4 No, he can't.
- 5 Yes, she can.

16

The message is:

Hi, I'm Rob. I'm ten. I'm from London. I like macaroni and ice cream.

Unit 6

1

- a 3, b 5, c 4, d 1, e 6, f 2

2

- 2 I have a shower.
- 3 I get dressed.
- 4 I have breakfast.
- 5 I brush my teeth.
- 6 I go to school.

3

- 2 I go to school - c.
- 3 I have breakfast - b.
- 4 I get dressed - e.
- 5 I brush my teeth - d.
- 6 I have a shower - a.

4

Children's own work .

5

- 2 T, 3 T, 4 F, 5 F

6

- 3 Tim can rollerblade.
- 4 Maria can play football.
- 5 Mike can't skateboard.

7

- 2 I can play football.
- 3 I can play tennis.
- 4 I can swim.
- 5 I can ride a bike.
- 6 I can skateboard.

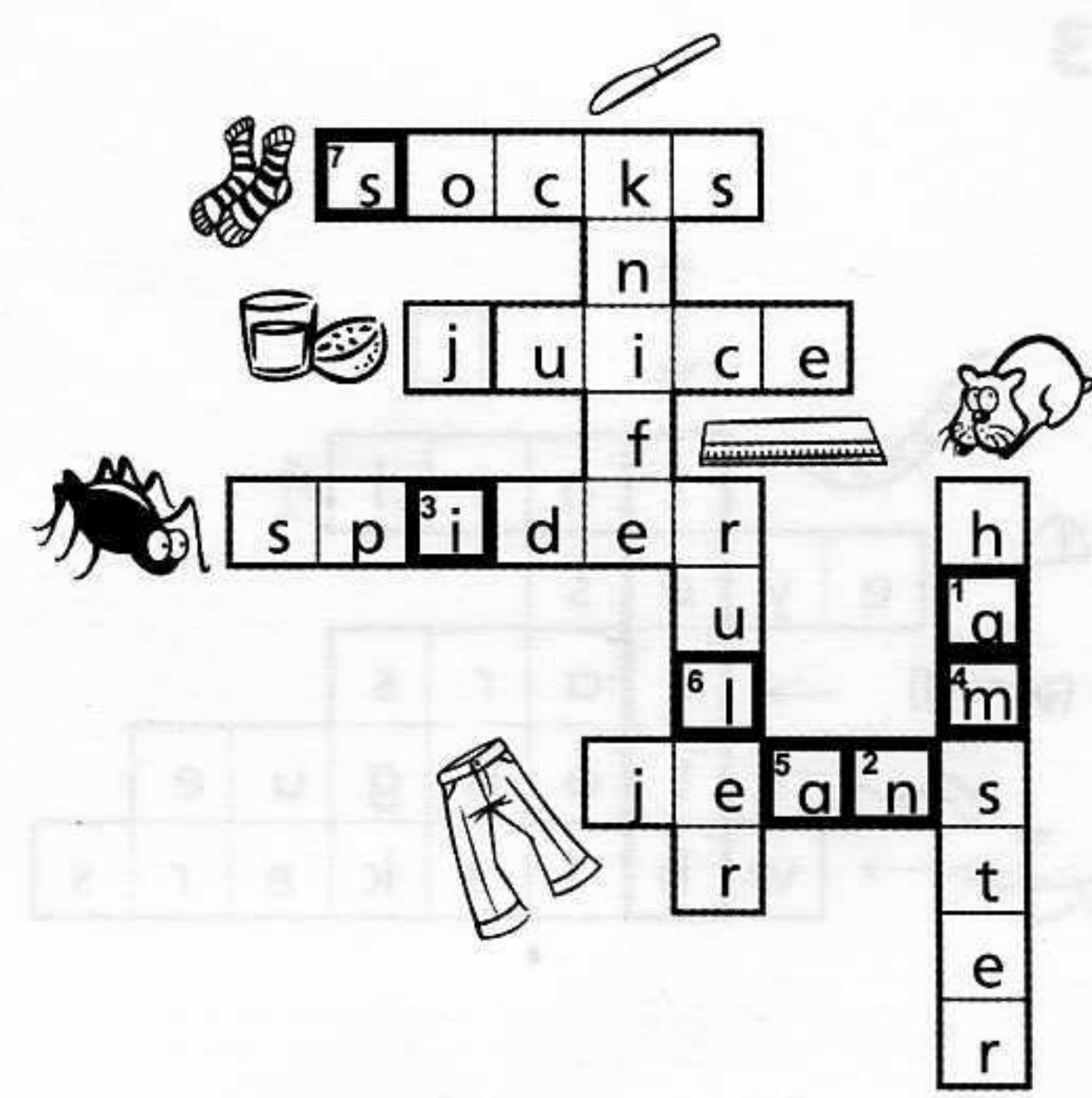

8

The secret word is: a n i m a l s.
1 2 3 4 5 6 7

9

- 1 b, 2 e, 3 a, 4 d, 5 c

10

- 1 Sports: rollerblade, play basketball, play football, skateboard
- 2 Numbers: fifty, fourteen, forty, twenty-five
- 3 Colours: orange, green, blue, yellow

11

- 2 I have a shower at half past seven.
- 3 I go to bed at half past nine.
- 4 I have dinner at half past eight.

12

Children's own work.

13

- 2 It's seven o'clock.
- 3 It's ten o'clock.
- 4 It's one o'clock.
- 5 It's half past seven.

14

- 2 T, 3 F, 4 F, 5 T, 6 T

15

- 2 I have lunch at half past one.
- 3 I have dinner at half past eight.
- 4 I go to bed at ten o'clock.

16

- 2 I have lunch at half past one.
- 3 I have dinner at half past seven.
- 4 I go to bed at nine o'clock.

Unit 7

1

- 2 park, 3 lake, 4 beach, 5 mountains, 6 country

2

- 2 Daniel: I go to the swimming pool in the summer.
- 3 Ben: I go to the mountains in the summer.
- 4 Sally: I go to the lake in the summer.

3
2 six, 3 seven, 4 three, 5 one

4
2 b, 3 a, 4 d

5
2 In Girona it's raining.
3 In Toledo it's sunny.
4 In Cádiz it's sunny.
5 In San Sebastian it's raining.
6 In Lugo it's cloudy.

6
2 b, 3 d, 4 a, 5 c

7
2-4 Children's own work.

8
2 Whales live in the sea. It's cold.
3 Tigers live in the jungle. It's hot.
4 Polar bears live in the Arctic. It's cold.
5 Gorillas live in the jungle. It's hot.
6 Penguins live in the Antarctic. It's cold.

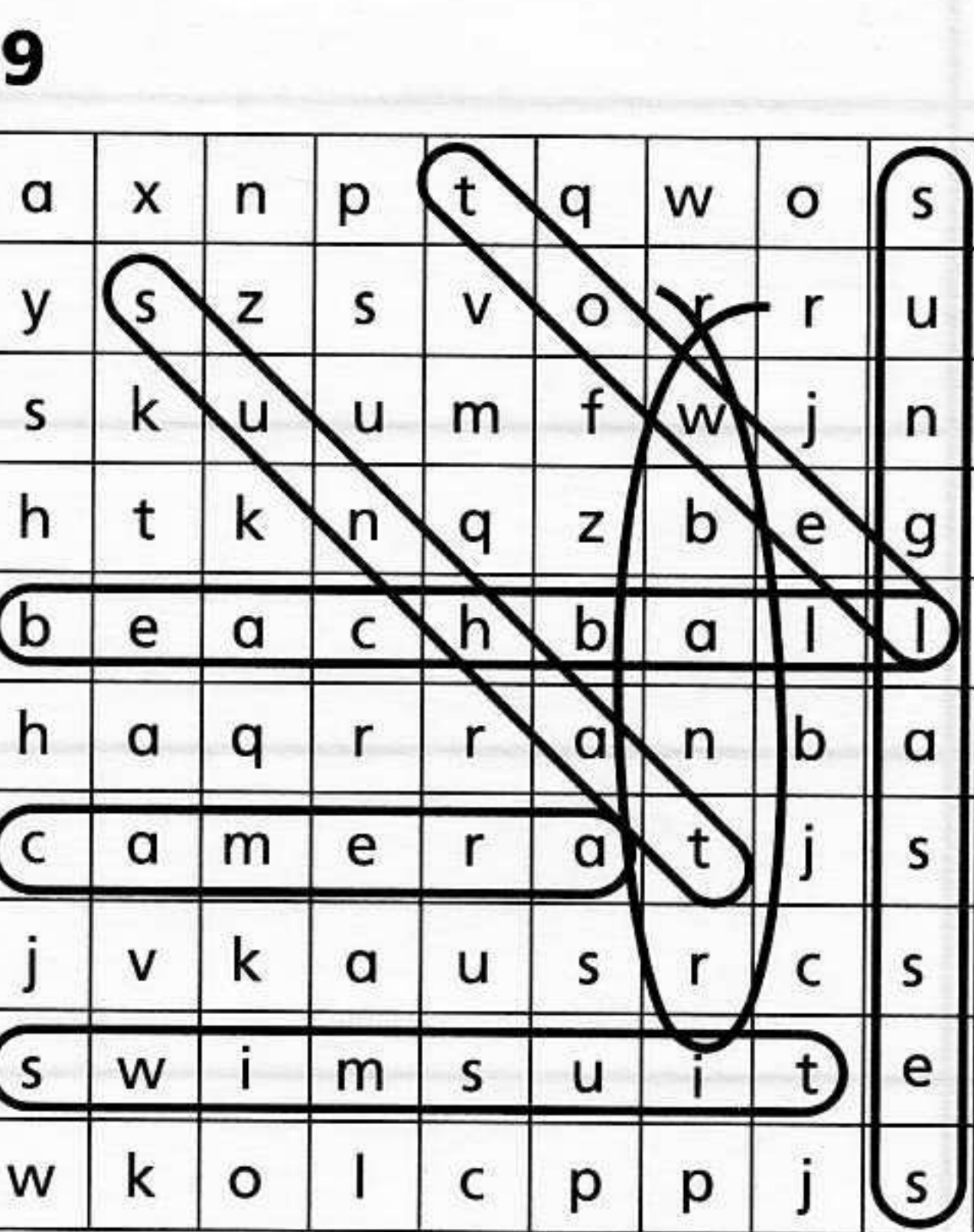

2 camera, 3 towel, 4 swimsuit, 5 sun hat,
6 suncream, 7 sunglasses

10
2 I've got a beachball and a swimsuit in my suitcase.
3 I've got a towel and a sun hat in my suitcase.

11
1 c, 2 a, 3 d, 4 b
d I'm wearing a dress, sun hat and sunglasses. I've got a camera.

12
Children's own work.

13
Children's own answers.

14
1 I go to the beach in the summer - a.
2 I get up at eight o'clock - e.
3 I'm wearing a T-shirt and jeans - d.

4 I can ride a bike - b.
5 I like fish and salad - c.

15
2 It's on the chair.
3 It's on the table.
4 It's in the suitcase.
5 It's in the suitcase.
6 It's under the chair.

16
1-6 Children's own answers.

Unit 8

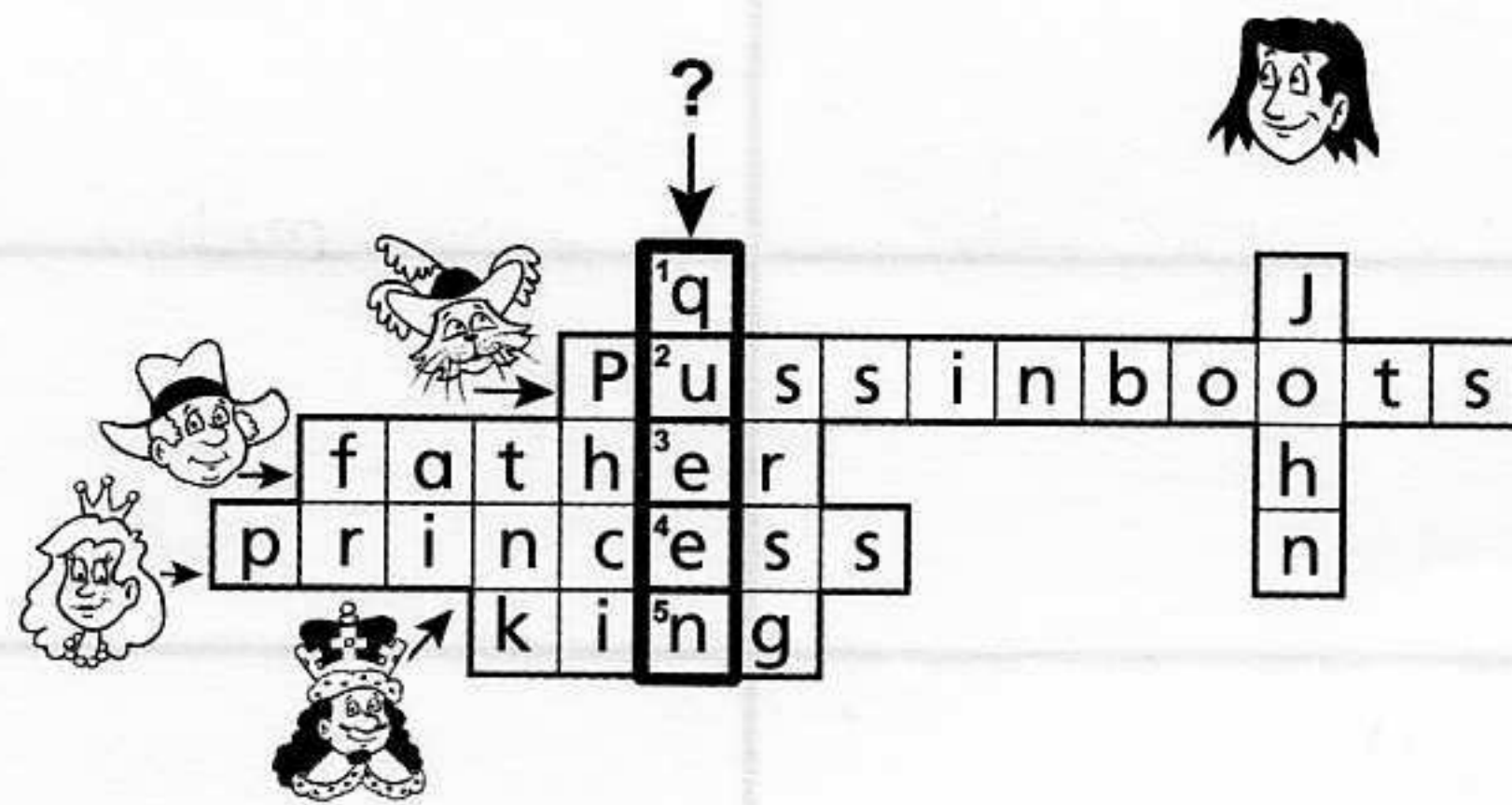

1
The secret word is: q u e e n
1 2 3 4 5

2
2 e, 3 a, 4 b, 5 c

3
b 2, c 5, d 1, e 3, f 4

4
2 She can't play basketball - false.
3 He can't play football - false.
4 She can play tennis - true.
5
2 rich d, 3 clever b, 4 daughter e,
5 boots c, 6 father f

6
2 She's under the tree.
3 He's on the chair.
4 She's in the swimming pool.

7
Dear Puss in boots,

It's hot and sunny. I'm at the beach. I got up at eleven o'clock. I have lunch at two o'clock. I play tennis and swim in the afternoon. I eat ice cream every day.

Love,
John

8
1 My suitcase: sunglasses, beachball, swimming trunks, hat
2 Holiday places: lake, park, mountains, swimming pool

9
2 old, 3 young, 4 rich, 5 clever,

6 handsome

10
2 He's wearing a hat, coat and shoes.
3 John is handsome.
4 The King is rich.
5 Puss in boots is clever.

11
Children's own work.

12
2 Amanda is young and clever. She's got sunglasses. She can rollerblade, but she can't ride a bike. She's got sunglasses. She's wearing a dress and shoes.
3 Paul is old and clever. He can play tennis, but he can't rollerblade. He's got sunglasses. He's wearing a T-shirt, jeans and a hat.

13
2 B, 3 B, 4 A, 5 A, 6 B

14
This is the Queen. She's got a hamster. She's wearing a crown and a dress and shoes. She's under a tree.

15
2 'I've got a dog and a hamster.'
3 'I've got a spider and a grasshopper.'

16
1 School: chair, pencil case, ruler, pencil, school bag
2 Animals: leopard, tiger, gorilla, whale
3 Colours: black, blue, pink, white
4 Places: swimming pool, beach, mountains