

CROSSCURRICULAR 1

3th B 16th-29th March 2020

Label. Read and colour. Cut out and stick.



bird flower grass leaves snake spider

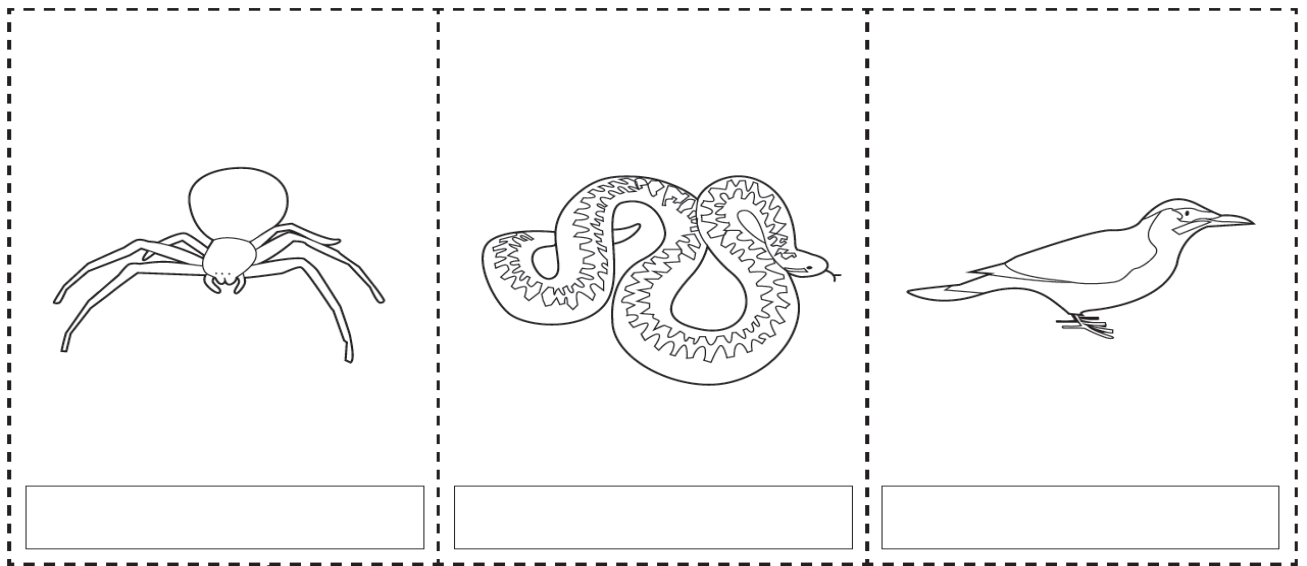
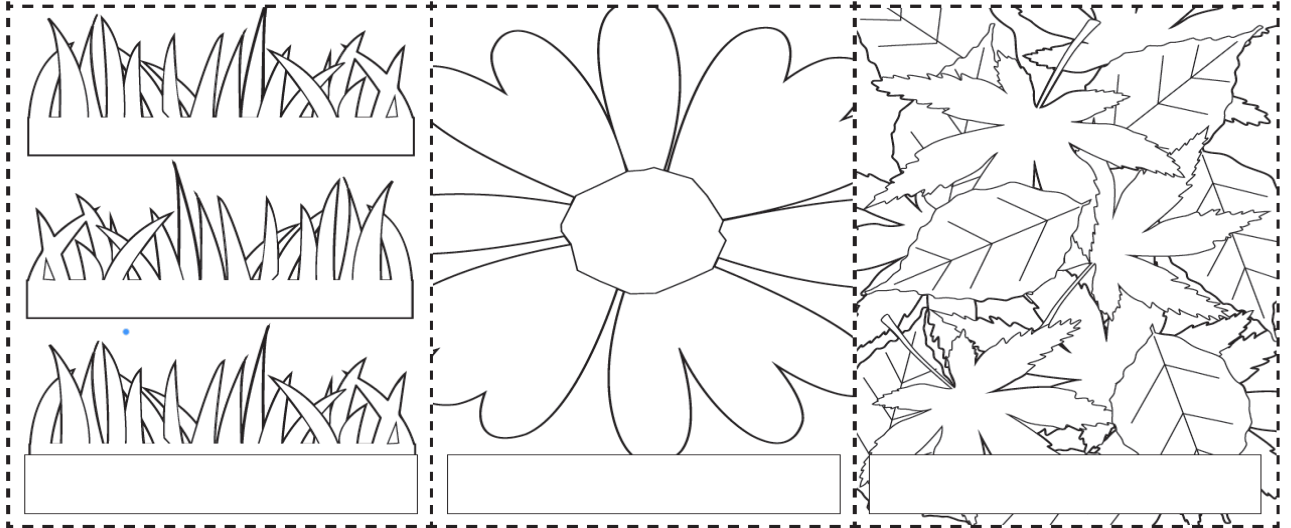

The snake is brown and black. It hides in the leaves. The leaves are brown. The snake is difficult to see.

The spider is yellow. It's in a flower. The flower is yellow. The spider is difficult to see.

The bird is green. It's in the grass. The grass is green. The bird is difficult to see.

CROSSCURRICULAR 2

3th B 16th-29th March 2020

Read, choose and tick ✓. Draw your castle.

My castle is on  a hill  a rock .

It's got 4 5 6  towers.

It's got  a moat.

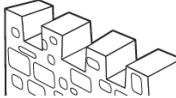
 thick walls.

 beautiful gardens.

 a bridge.

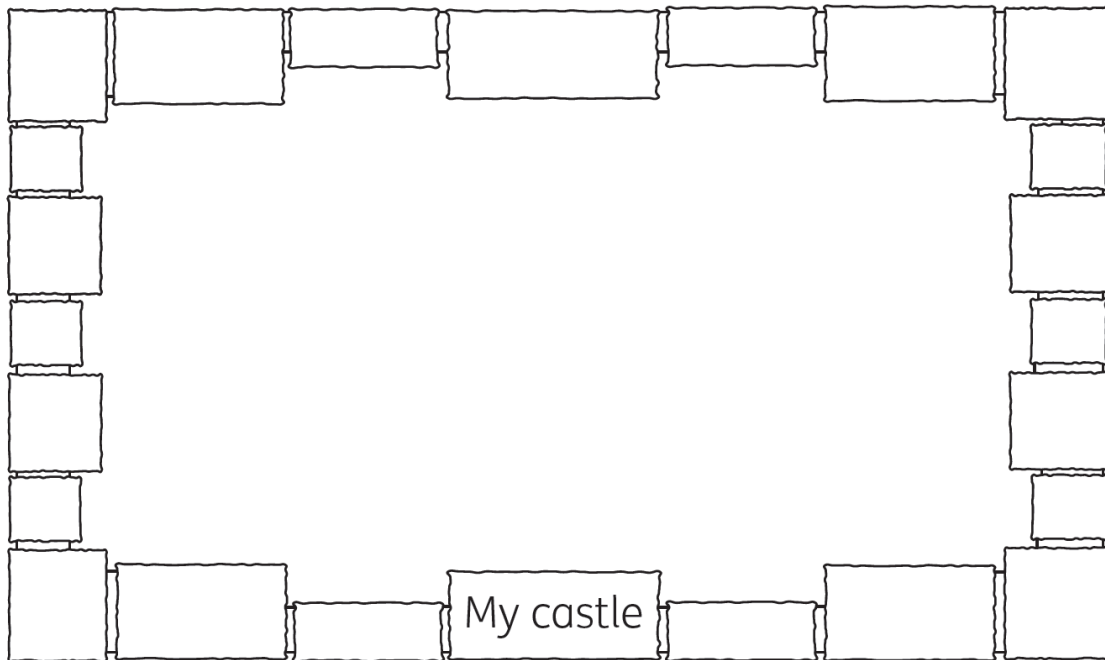

Read and match. Make an instrument.

1 This is a wind instrument. You play it with your mouth. Make it with bottles and water.

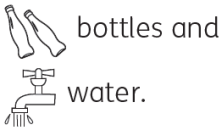

2 This is a string instrument. You play it with your hands. Make it with a pot and rubber bands.

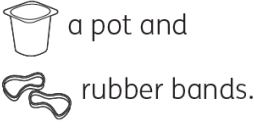

3 This is a percussion instrument. You play it with your hands. Make it with a pot, a balloon, and tape.

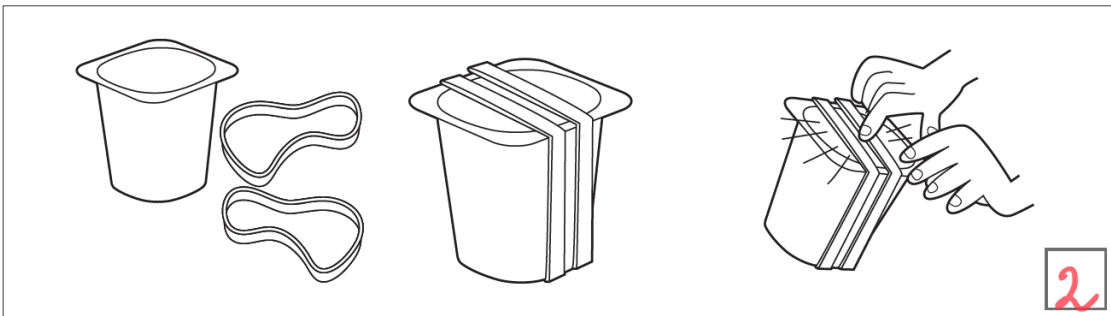
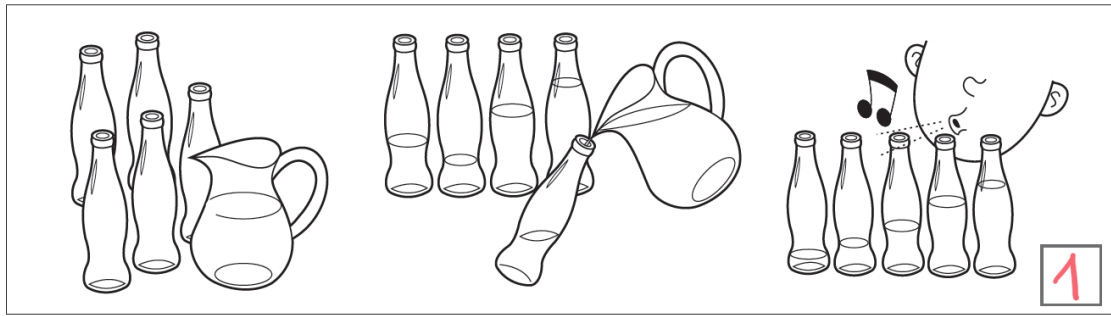
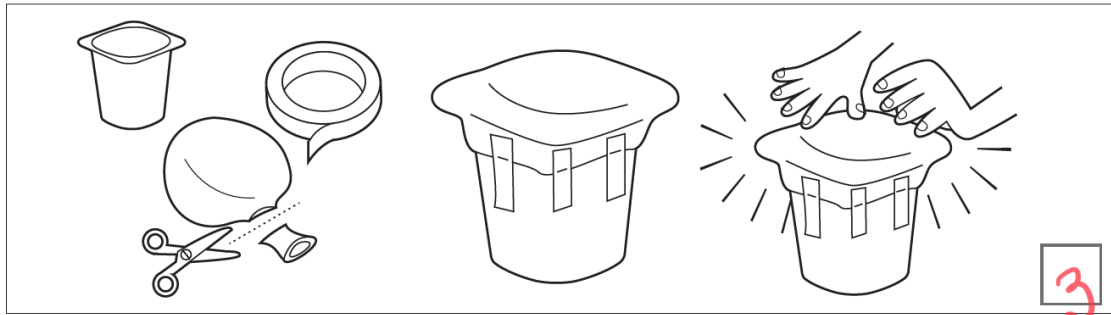
Cut. Read and stick.

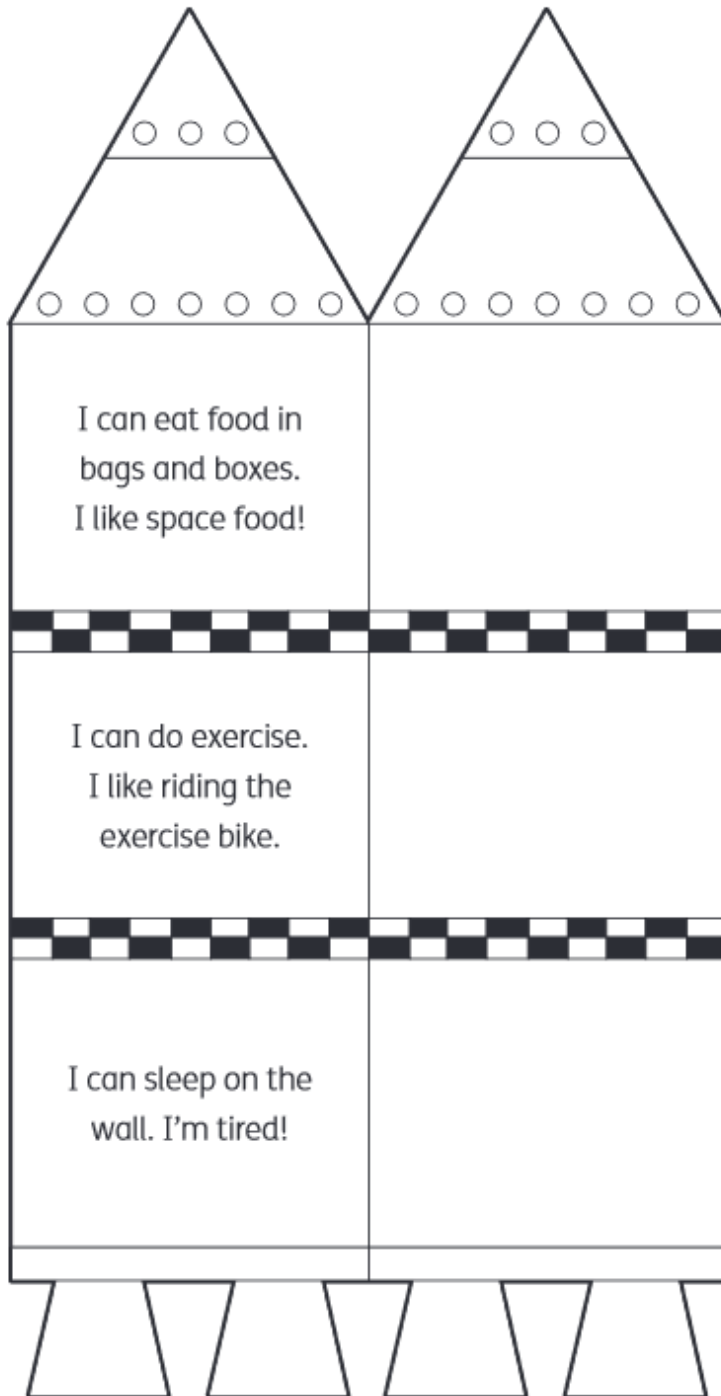

WORKSHEET 1

3th B 16th-29th March 2020

1 Write the numbers in order. Match.

~~eighty~~ ~~fifty~~ ~~forty~~ ~~ninety~~ ~~one hundred~~ ~~seventy~~ ~~sixty~~ ~~ten~~ ~~thirty~~ ~~twenty~~

ten _____
 twenty _____
 thirty _____
 forty _____
 fifty _____
 sixty _____
 seventy _____
 eighty _____
 ninety _____
 one hundred _____

2 Write.

~~retsis~~ ~~ynrgan~~ ~~umrn~~ ~~yabb~~ ~~add~~ ~~addnarg~~ ~~erthorb~~

1 grandad

2 granny

3 brother

4 sister



5 dad

6 mum

7 baby

WORKSHEET 2







3th B 16th-29th March 2020

1 Match.

a	$16 + 7 =$	twenty-two
b	$12 + 13 =$	twenty-five
c	$19 + 8 =$	twenty-three
d	$15 + 14 =$	twenty-seven
e	$11 + 10 =$	twenty-one
f	$18 + 6 =$	twenty-six
g	$13 + 9 =$	twenty-nine
h	$16 + 12 =$	twenty-four
i	$11 + 15 =$	twenty-eight

2 Write.

kite bike ball phone car doll ~~book~~ dog

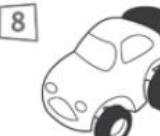
1 	2 	3 	2 1 b a o k	4 K I T
4 	5 	6 	3 P H O N e	
7 	8 		6 5 d O L L	8 C 7 B a L L R

WORKSHEET 3

3th B 16th-29th March 2020

1 Colour.

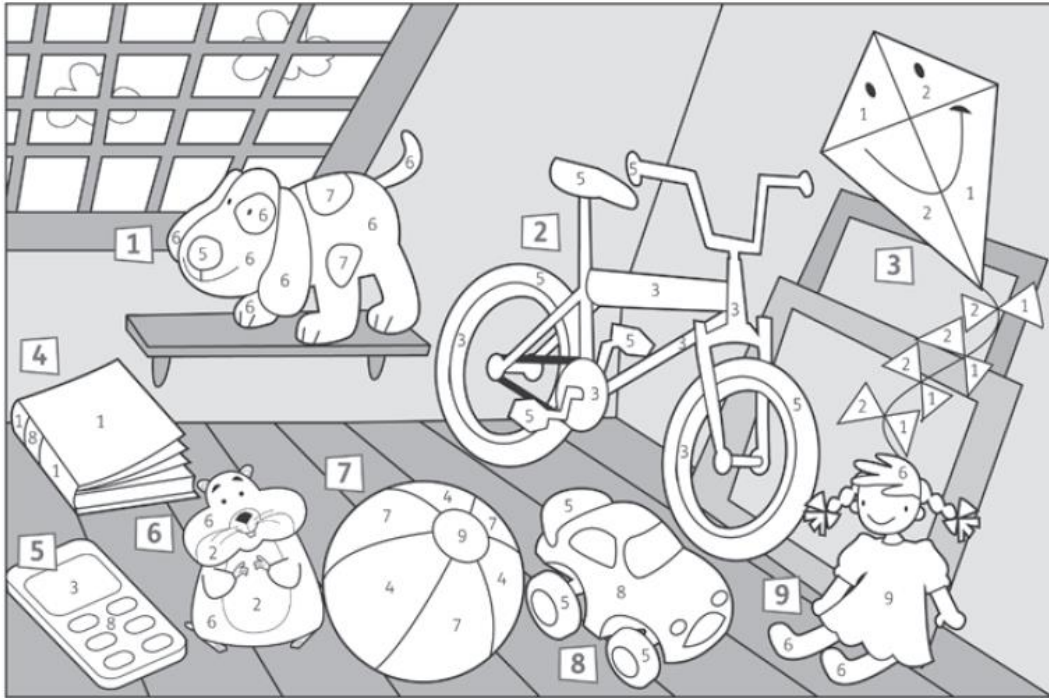

- | | | | | |
|-----------|------------|------------|-----------|-----------|
| 1 = red | 2 = yellow | 3 = blue | 4 = green | 5 = black |
| 6 = brown | 7 = purple | 8 = orange | 9 = pink | |

2 Colour the toys. Write.

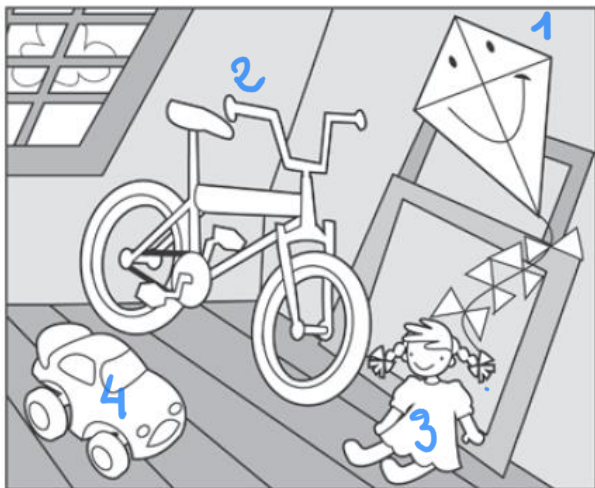

- 1 It's a kite
It's red and yellow.
- 2 It's a bike
It's blue and black.
- 3 It's a doll
It's pink and brown.
- 4 It's a car
It's orange and black.

WORKSHEET 4

3th B 16th-29thMarch2020

1 Find and write.

~~crocodile~~ ~~flamingo~~ ~~giraffe~~ ~~gorilla~~ ~~lion~~ ~~zebra~~

- 1 What's this? It's a gorilla
- 2 What's this? It's a giraffe.
- 3 What's this? It's a flamingo.
- 4 What's this? It's a lion.
- 5 What's this? It's a zebra.
- 6 What's this? It's a crocodile.



2 Join the dots. Write Yes, it is or No, it isn't.

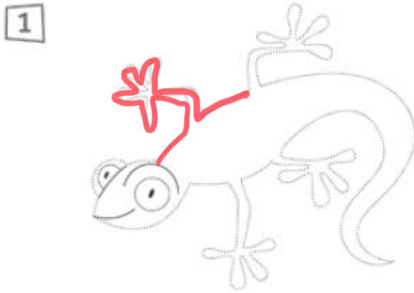

What's this? Is it a lizard?

Yes, it is



What's this? Is it a flamingo?

No, it isn't



What's this? Is it a panther?

Yes, it is

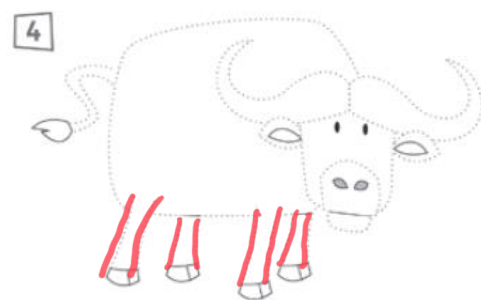

What's this? Is it a lion?

No, it isn't

WORKSHEET 5

3th B 16th-29th March 2020

1 Colour. Write.

1 = brown 2 = yellow 3 = green 4 = pink 5 = black 6 = white 7 = blue

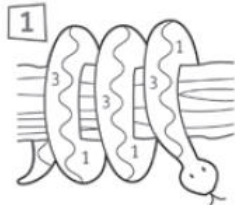

What's this? It's
a green and
brown snake.

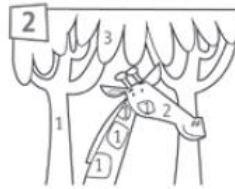

What's this? It's
a brown and
yellow giraffe.



What's this? It's
a pink
flamingo.



What's this? It's
a brown and
yellow lion.



What's this? It's
a black eagle.

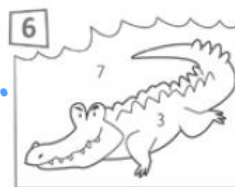

What's this? It's
a green
crocodile.

2 Look and write.



1 What's this?
Is it a tree?



No, it isn't.
It's a giraffe.

2 What's this?
Is it a plant?



No, it isn't.
It's a lion.

3 What's this?
Is it a river?



No, it isn't.
It's a snake.

4 What's this?
Is it a rock?



No, it isn't.
It's a buffalo.

WORKSHEET 6

3th B 16th-29th March 2020

1 Read and tick ✓.

1



I've got a rubber.

I've got a ruler.

2



I've got a folder.

I've got a felt-tip.

3



I've got a calculator.

I've got a sharpener.

4



I've got a felt-tip.

I've got a glue stick.

5



I've got a dictionary.

I've got a notebook.

6



I've got a ruler.

I've got a pencil case.

2 Draw things in your pencil case. Read and write Yes, I have or No, I haven't.

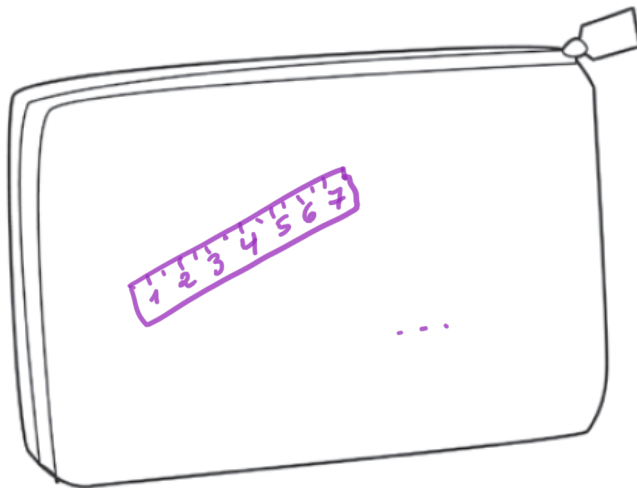

1 Have you got a felt-tip?

2 Have you got a pencil?

3 Have you got a rubber?

4 Have you got a ruler?
Yes, I have

5 Have you got a glue stick?

1 Count and write.



I've got five pencils.
 I've got three pencil cases.
 I've got four felt-tips.
 I've got two calculators.
 I've got seven rulers.
 I've got six pens.
 I've got six glue sticks.
 I've got four notebooks.

2 Read and complete.

1 Have you got a pencil?

No, I haven't.
 I've got a ruler.



2 Have you got a ruler?

Yes, I have.



3 Have you got a folder?

No, I haven't.
 I've got a notebook.



4 Have you got a sharpener?

Yes, I have.



WORKSHEET 8

3th B 16th-29thMarch2020

1 Look and write *I can* or *I can't*.

	Anna	David
	✓	✓
	X	✓
	X	✓
	✓	X
	✓	✓



Anna

I can swim.
I can't ski.
~~*I can't*~~ surf.
~~*I can*~~ sail.
~~*I can*~~ ride a bike.



David

~~*I can*~~ swim.
~~*I can*~~ ski.
~~*I can*~~ surf.
~~*I can't*~~ sail.
~~*I can*~~ ride a bike.

2 Match and write *Yes, I can* or *No, I can't*.

1 Can you play volleyball?



No, I can't

2 Can you skate?



Yes, I can.

3 Can you play football?



No, I can't

4 Can you do karate?



Yes, I can

5 Can you dive?



No, I can't





6 Can you play tennis?



Yes, I can

1 Find and write.



- | | | | |
|--|--------------------------|--|-----------------------|
| 1  | She can play volleyball. | 2  | He can't play tennis. |
| 3  | She can't skate. | 4  | He can do karate. |
| 5  | She can't ride a bike. | 6  | He can play football. |

2 Write the words in order. Answer for you. Write Yes, I can. or No, I can't.

- 1 karate? Can do you
 Can you do karate? No, I can't
- 2 you recorder? Can the play
 Can you play the recorder? Yes, I can
- 3 a you bike? Can ride
 Can you ride a bike? Yes, I can
- 4 play Can the you violin?
 Can you play the violin? No, I can't
- 5 volleyball? you play Can
 Can you play volleyball? Yes, I can
- 6 Can guitar? you the play
 Can you play the guitar? No, I can't

1 Read and tick ✓ or cross x.



- | | | | |
|-----------------------|-------------------------------------|------------------------|-------------------------------------|
| 1 Mia likes peaches. | <input checked="" type="checkbox"/> | 5 Tom likes soup. | <input type="checkbox"/> |
| 2 She likes rice. | <input type="checkbox"/> | 6 He likes sandwiches. | <input checked="" type="checkbox"/> |
| 3 She likes sausages. | <input type="checkbox"/> | 7 He likes vegetables. | <input checked="" type="checkbox"/> |
| 4 She likes burgers. | <input checked="" type="checkbox"/> | 8 He likes eggs. | <input type="checkbox"/> |

2 Look and write. Answer for you. Write Yes, I do or No, I don't.

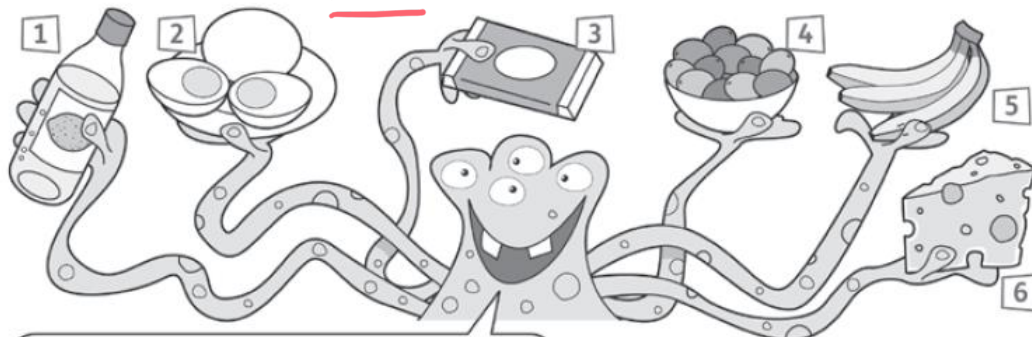

- | | |
|---------------------------------|--------------------|
| 1 Do you like <u>lemonade?</u> | <u>Yes, I do</u> |
| 2 Do you like <u>eggs?</u> | <u>Yes, I do</u> |
| 3 Do you like <u>chocolate?</u> | <u>Yes, I do</u> |
| 4 Do you like <u>peaches?</u> | <u>Yes, I do</u> |
| 5 Do you like <u>bananas?</u> | <u>No, I don't</u> |
| 6 Do you like <u>cheese?</u> | <u>Yes, I do</u> |

1 Look and join.

1  He likes yoghurt.
She likes eggs.

2  I like chocolate.
likes crisps.

3  He like sandwiches.
She likes

4  He likes lemonade.
She likes pears.

5  I like peaches.
likes olives.

6  He like biscuits.
She likes

2 Follow and write the questions. Answer for you.

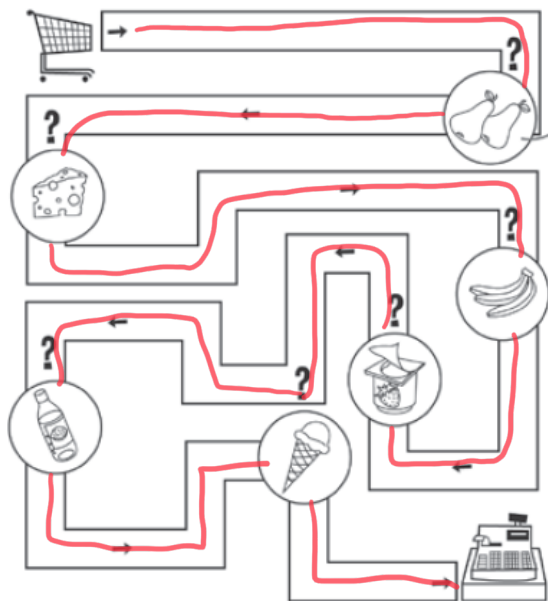

- 1 Do you like pears?
Yes, I do.
- 2 Do you like cheese?
Yes, I do.
- 3 Do you like bananas?
No, I don't.
- 4 Do you like yoghurt?
Yes, I do.
- 5 Do you like lemonade?
Yes, I do.
- 6 Do you like ice-cream?
Yes, I do.